

# SERVICE NOTES

## EVORA

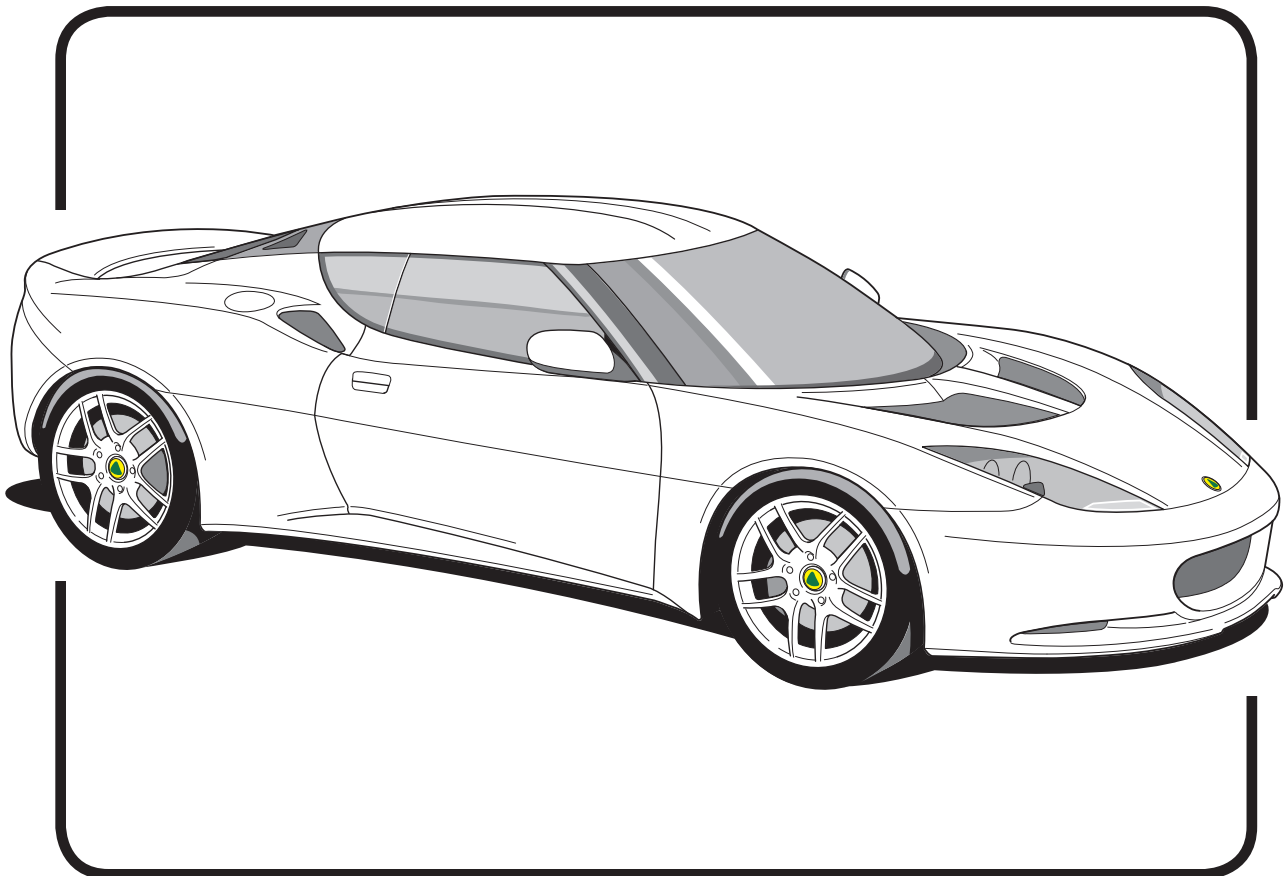

Lotus Cars Ltd. Hethel, Norwich, Norfolk, NR14 8EZ, England.  
Tel: +44 (0)1953 608000 Fax: +44 (0)1953 608300 [www.LotusCars.co.uk](http://www.LotusCars.co.uk)

This publication has been designed for use by Lotus Dealers familiar with general workshop safety procedures and practices. Take all appropriate action to guard against injury to persons or damage to property.

Lotus policy is one of continuous product improvement, and the right is reserved to alter specifications at any time without notice.

Whilst every care has been taken to ensure correctness of information, it is impossible to guarantee complete freedom from errors or omissions, or to accept liability arising from such errors or omissions, but nothing herein contained shall affect your statutory rights.



## CONTENTS

### LOTUS EVORA

	<u>Section</u>
Technical Data - Engine - Vehicle	TDT TDU
Chassis	AJ
Bodycare & Repair	BU
Body Fittings	BV
Front Suspension	CK
Rear Suspension	DJ
Engine & Engine Management - Lotus supplement - Toyota engine repair manual	EJ *
Engine Management	EMR
Transmission - Lotus supplement - Toyota transmission manual	FL #
Wheels & Tyres	GJ
Steering	HI
Brakes	JL
Engine Cooling	KJ
Fuel System	LN
Electrics	MR
Maintenance & Lubrication	OK
Air Conditioning, Heating & Ventilation	PN
Clutch	QJ
Interior Trim	VE
Passive Restraint	WF

\* see separate CD: T000T1516F

# see separate CD: T000T1517F



**VEHICLE IDENTIFICATION NUMBER & ENGINE NUMBER**

The Vehicle Identification Number (V.I.N.) is a unique 17-digit number used to identify the car for licencing, warranty, spares ordering and administrative purposes.

The chassis frame is stamped with the V.I.N. on the crossmember beneath the driver's seat, accessible inside the cabin with the seat slid fully rearwards. Pull back a flap in the carpet to view. The number is also printed on a label stuck to the vertical face of the fuel tank bay, below the front edge of the right hand rear seat cushion or luggage shelf. Pull back a flap in the carpet to view.

It is essential that the complete V.I.N. is quoted in any correspondence concerning the car, or when ordering spare parts.

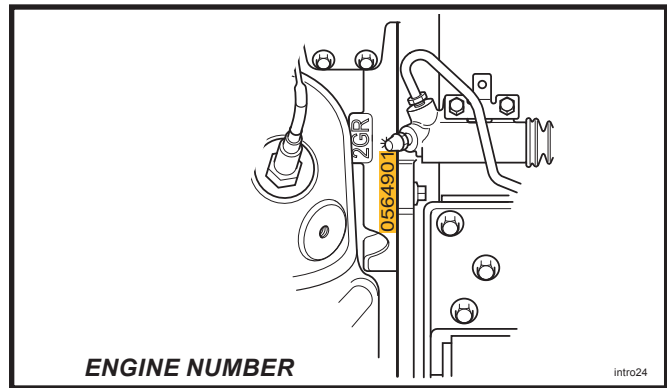
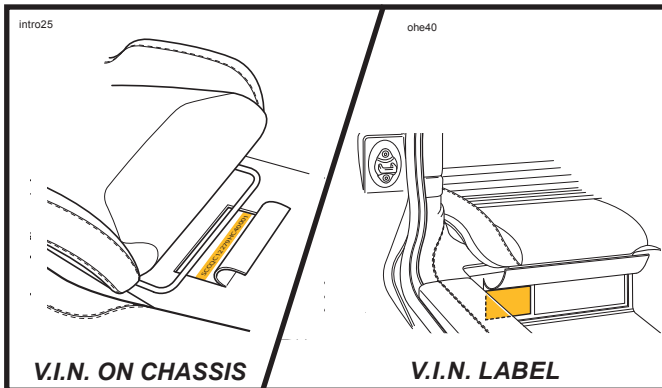

**Engine Number**

The 6-digit engine serial number is stamped on the LH rear flange of the cylinder block, alongside the clutch housing jointface, and is viewable only from beneath after removal of the engine undertray. The number is repeated on a bar code label applied to the front face of the left hand cylinder head, which may be viewed from above using a mirror.

The full V.I.N. should always be quoted with any vehicle enquiries, together with the engine number if the query is engine related. Factory records are filed against V.I.N., and specification change points are identified by V.I.N. or engine number.

The V.I.N. comprises 17 characters, coded in accordance with European Economic Community (EEC) directives, or, for the USA, with those of the National Highway Traffic Safety Association (NHTSA). For change point identification in Service Notes, Service Bulletins and Service Parts Lists, typically, only characters 10 (model year), and 14 to 17 (serial number) will be quoted.

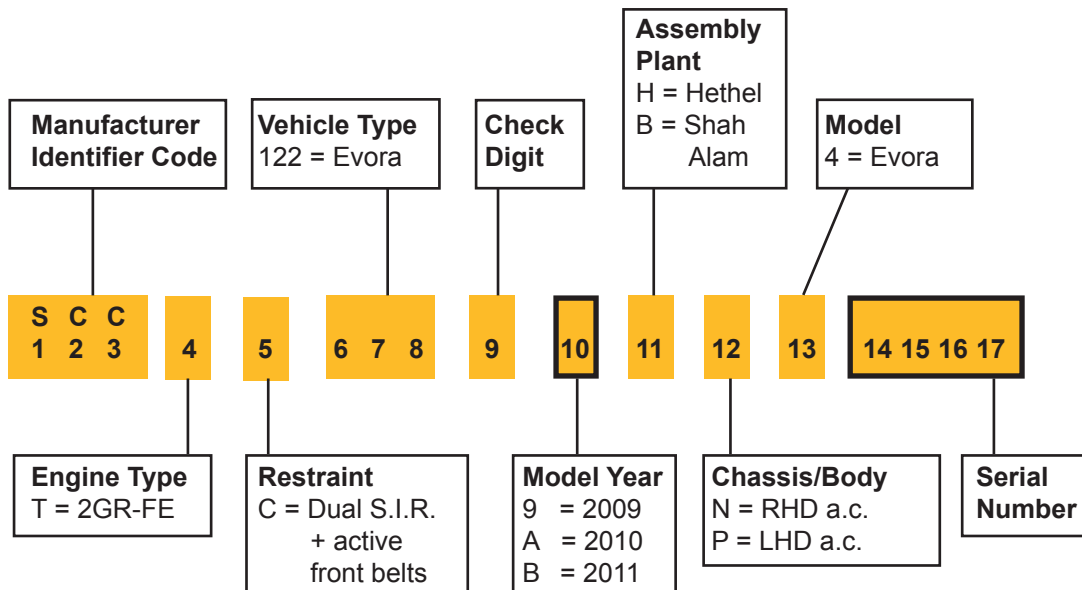

120U0113



**MODEL HISTORY**

**Evora Introduction:**

First deliveries commence June 2009 at '09 VIN serial number 0721.



**LIFTING POINTS**

When using a lifting jack or hoist, care must be taken to position the device only beneath the areas shown in the illustration. Each designated point uses a ribbed alloy reinforcement pad integral with the main chassis structure. Use a suitable rubber pad to provide additional protection from surface damage:

- A; Identified by a blue sticker. Beneath the front ends of the chassis main siderails, just behind the rear edge of the front undertray.
- B; Identified by a blue sticker. Beneath each end of the fuel tank bay rear crossmember, just ahead of the front edge of the engine bay undertray.

If using a single jack for wheel changing purposes, a single rear lifting point (B) may be used to raise both wheels on that side of the car. With the limited vision available under these circumstances, extra care must be taken to position the jack correctly.

Note that in order fully to exploit the benefits of light weight, and to maximise stowage space, the Evora has no provision for spare wheel carriage or lifting jack. A temporary puncture recovery facility is provided in the form of a tyre inflator aerosol stowed in the right hand side of the boot.

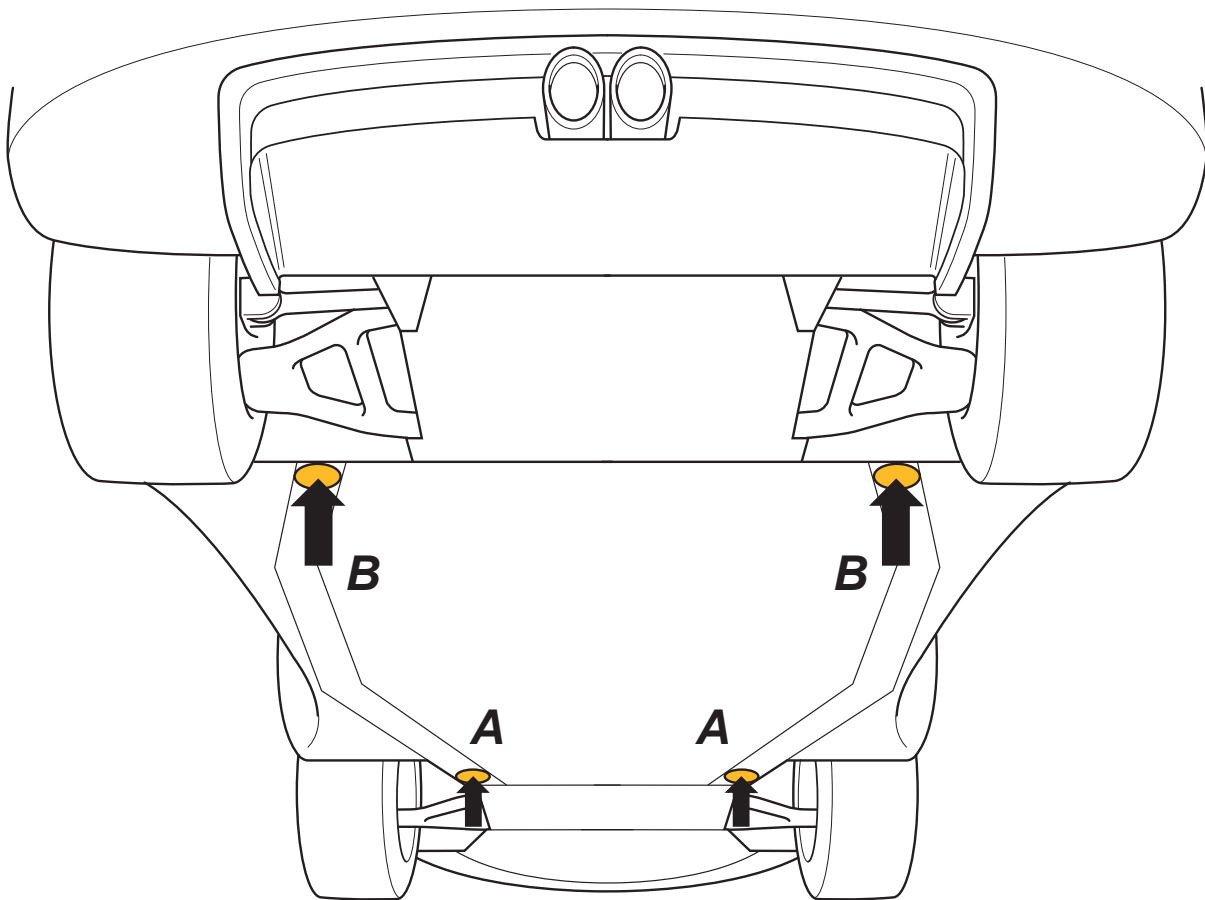

one52



CHASSIS

SECTION AJ

	<u>Sub-Section</u>	<u>Page</u>
General Description	AJ.1	3
Chassis Straightness Check	AJ.2	4
Rear Subframe	AJ.3	5
Front Subframe	AJ.4	6



A31

**EAGLE MAIN CHASSIS TUB**

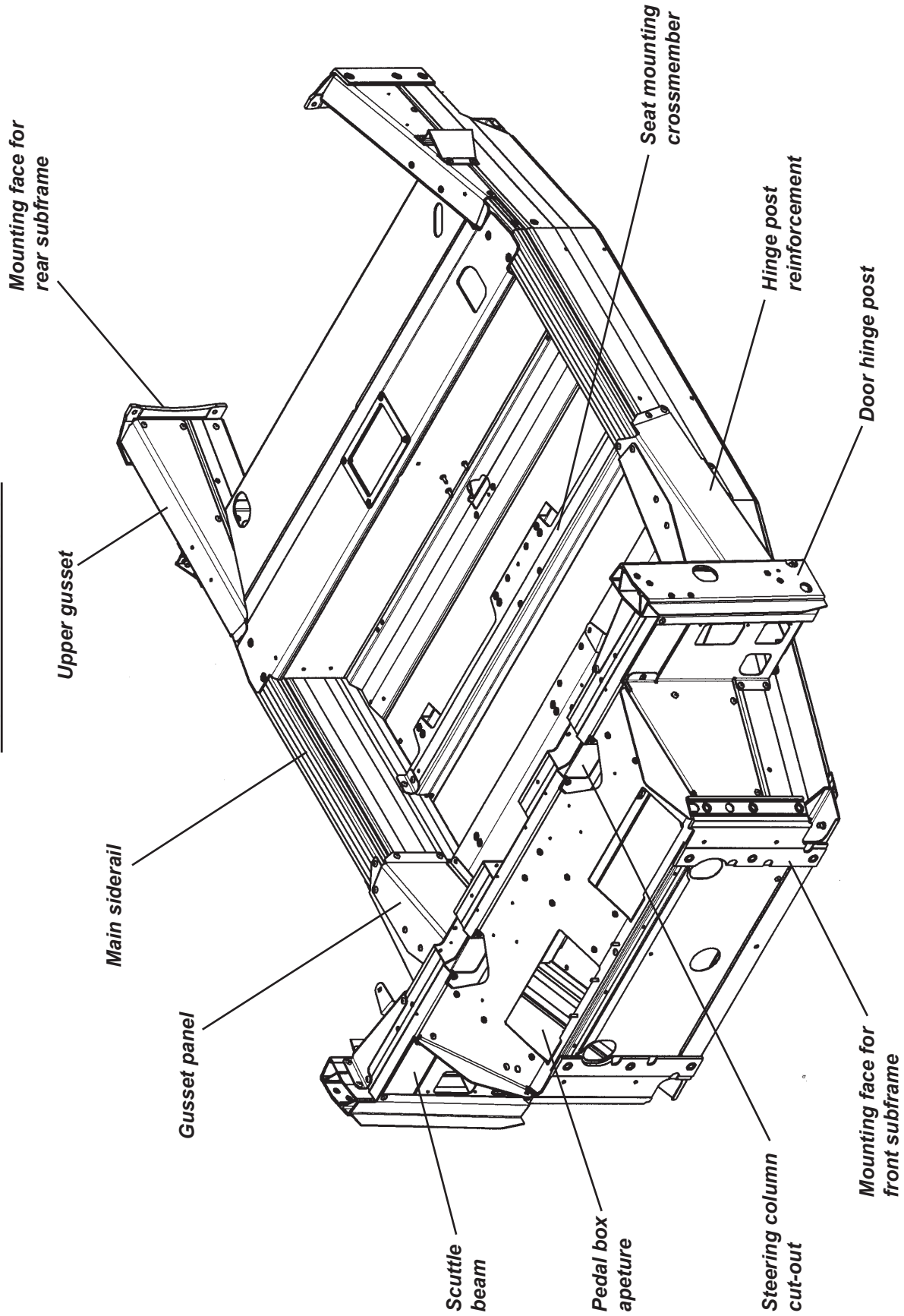



**AJ.1 - GENERAL DESCRIPTION**

The chassis frame of the Lotus Eagle is constructed primarily from aluminium alloy extrusions and formed alloy sheet, with the various sections bonded together using an epoxy adhesive with secondary drive-in fasteners. The main chassis unit includes the passenger cell, footwells, front bulkhead, front scuttle with door hinge posts and the fuel tank bay. At the rear, the main chassis siderails extend rearwards beyond the fuel tank bay and alongside the engine bay, to terminate in mounting faces for the galvanised steel rear subframe. Similarly, the front bulkhead/toe board provides mountings for the alloy front subframe. A large diameter tubular steel seat belt mounting frame is bolted to the top face of the chassis side members, and incorporates a roof hoop with backstays for additional occupant protection.

The cabin rear bulkhead, body sills (inc. 'B' posts), roof panel, and windscreen mounting frame, are all constructed from glass fibre composite and are bonded to the chassis structure using an elastomeric adhesive. The front and rear outer body clamshells are each constructed from glass fibre composite mouldings, fixed to the body and chassis structure with threaded fasteners to facilitate service access and economic repair.

Two main chassis siderail extrusions, 226mm wide and 80mm deep, each comprising three box sections, run along each side of the passenger compartment between the front and rear subframe mountings. Each member incorporates two bends to allow the siderails to angle inwards afore and behind the seating area in order to accommodate the wheel wells. Each bend is formed by notching the extrusion, bending the outer wall and restoring the three cut faces with bonded and riveted patches. The front joint is reinforced by an inboard gusset panel, and the rear joint by the fuel tank crossmember. At the rear, each siderail is raised above the lower wishbone front pivot by having the siderail lowermost section machined away, and adding a folded upper gusset to the siderail top surface, to reinforce a vertical end face used for attachment of the rear subframe suspension tower.

Five crossmembers link the bottom of the two siderails; one at the toe-board, two bonded together at the seat front mountings, one for the seat rear mountings, and one across the front of the fuel tank bay. Two single skin sheet sections are used to complete the cabin floor.

Behind the passenger cell, the siderails are linked by a pair of transverse crossmembers which are used in conjunction with a folded sheet upper panel to form an open bottomed fuel tank cell with a detachable, screw fixed, lower closing panel. Note that this closing panel contributes to the structural integrity of the chassis, such that the vehicle should not be operated without it properly fitted.

The front scuttle structure comprises a scuttle beam, the two door hinge posts and the footwells. A vertical extrusion is used to form each door hinge post, which is secured to the end of the scuttle beam, and, by a rearwards leading tapering channel section, to the chassis siderail. Perforated flat plates are also used to tie the lower ends of the hinge posts to the siderails. The folded sheet footbox links the front of the scuttle beam to the siderails, the toe-board and to vertical strongpoints which are used to terminate the front end of the siderails and provide mounting points for the front subframe.

A galvanised, sheet steel, fabricated rear subframe, provides mountings for the rear suspension, powertrain and exhaust muffler, and is bolted to the rear ends of the chassis siderails. The subframe also serves as a deformable crash structure to provide the necessary energy dissipation in the event of a rear impact. This feature also facilitates accident repair by separating the suspension mounting points from the main chassis structure.

At the front of the car, a front subframe uses the same construction techniques as the main chassis tub, with aluminium alloy extrusions bonded and riveted together to provide mounting points for the front suspension, front body clamshell and cooling radiators, and also houses the heating/a.c. system. The structure consists primarily of a box section extrusion at each side, continuing forwards from the front of the chassis tub to which each side is fixed by a 6 bolt flange. These two longerons, house the mounting points for the top wishbone pivots and carry drop towers down to the lower wishbone pivots. The foremost of these are linked by a lower crossmember which also carries the power steering rack, with the whole area reinforced by a bolted upper crossmember/bulkhead panel forming the front of the HVAC chamber. The front ends of the longerons are linked by another crossmember secured at each side by two M8 fixings. The construction of the subframe also serves to dissipate energy and control the rate of deceleration sustained by the occupants in a frontal collision. As at the rear, this feature also facilitates accident repair by separating the suspension mounting points from the main chassis structure.

Note that the whole of the chassis structure as so far described, is machined to allow assembly into right or left hand drive configuration.

The bonded and rivetted main chassis tub described above is considered a non-serviceable single unit, jig built to fine tolerances, to which no structural repairs are approved. Superficial, cosmetic, or non-structural localised damage may be cosmetically repaired as necessary, but in the case of accident damage resulting



in significant bending, tearing or distortion of the aluminium structure, especially in respect of the attachment points for the front and rear subframes, the recommended repair is to renew the partial body assembly, which comprises the main chassis tub, with jig bonded composite rear bulkhead, body sills and windscreen frame. Also included are the pipes and cables routed through the body sill mouldings.

### AJ.2 - CHASSIS STRAIGHTNESS CHECK

In the absence of visual damage, the chassis may be checked for twist or distortion by utilising the machined tooling indents in the underside of the main side rails. If computer processed laser measuring equipment is not available, manual checks can be made with reference to a completely level ground plane, e.g. an accurately set and maintained suspension geometry ramp/lift. Position the car on the lift, and proceed as follows:

1. Identify the tooling indents in the lower surface of each chassis main side rail. At the front end, just behind the front crossmember, and at the rear, just ahead of the fuel tank bay rear crossmember. Note that three of the machined oval areas are drilled, but not at the left hand rear.
2. Measure the height of each tooling indent above the reference plane and use jacks to adjust the height of the chassis in order to equalise any three of these dimensions.
3. Measure the deviation of the fourth dimension from the other three.  
Maximum service deviation =  $\pm 2.0$  mm.
4. Repeat operations (2) and (3) for each combination of corners to result in four values for the 'fourth' dimension deviation. If any one of these exceeds the service specification, the chassis should be considered damaged and replaced by a partial body assembly.

*Illustration to follow*



AJ.3 - REAR SUBFRAME

The rear ends of the chassis siderails are linked by a fabricated sheet steel subframe which provides mountings for the powertrain, rear suspension, rear body, exhaust muffler and seat belt mounting frame struts. The subframe is aligned to each of the siderails by an 8mm roll pin, and secured by seven M10 x 30, 8.8 grade bolts. It is possible to remove the subframe from the chassis complete with powertrain and suspension attached, although access to some fixing bolts will be restricted, and alignment on refitment may be difficult.

**To remove/refit rear subframe**

1. Remove rear body and disconnect all pipes, hoses, harnesses and cables.
2. Remove the seat belt mounting frame rear struts.
3. Support the rear subframe before progressively and evenly removing the seven fixing bolts from each side of the frame:  
At each side;
  - Two bolts from beneath into threaded inserts in the chassis rail lower surface;
  - Three bolts into captive nuts in the chassis rail side face;
  - Two bolts from within the engine bay using loose nuts ahead of the siderail closing plate.
4. Withdraw the subframe taking note of the shim plates fitted at each side between the bottom of the siderail and the subframe.
5. On re-assembly, first trial fit the subframe to the chassis, using no shim plates. Locate the subframe by engaging the roll pins into the dowel holes in the chassis rail rear closing plates and secure at each side by temporarily fitting the two bolts and nuts through the closing plates. Measure the gap between the bottom of each chassis siderail and the subframe horizontal surface, and select the appropriate number of 1mm shim plates.

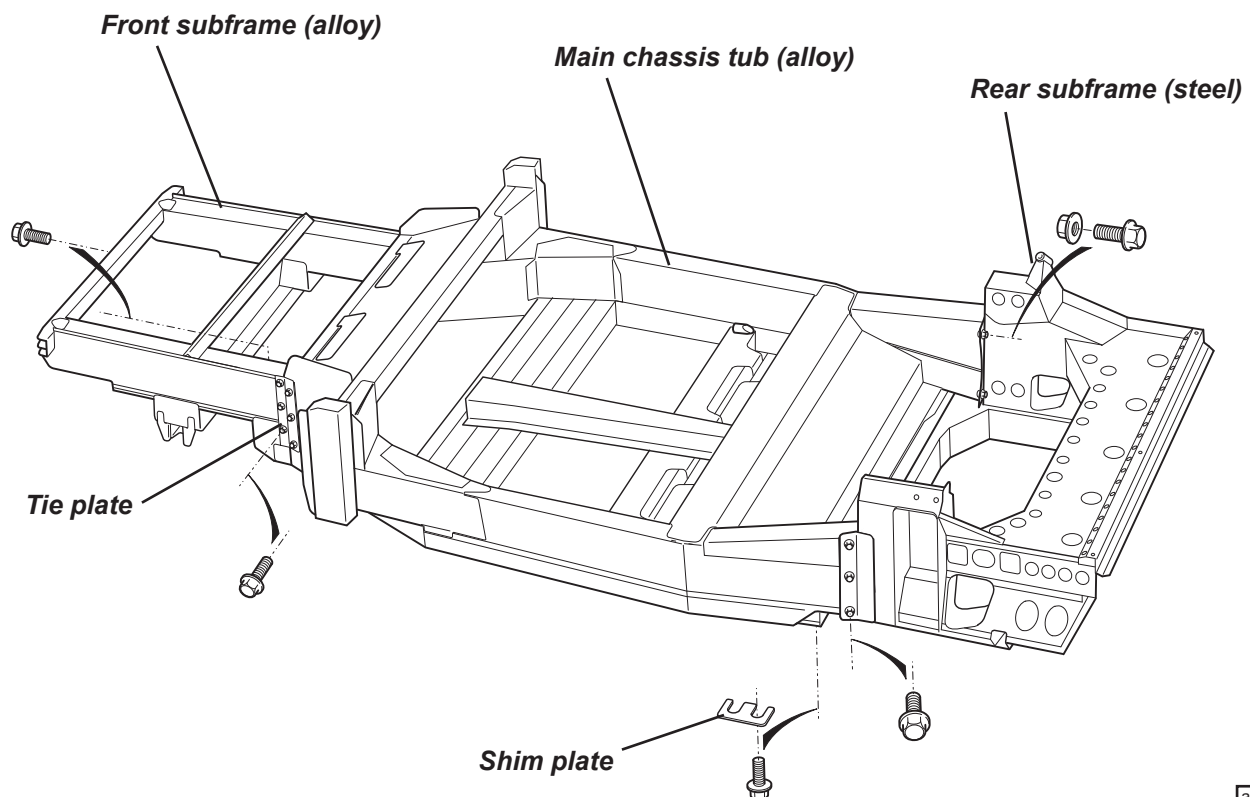

a32



6. Re-assemble the subframe to the chassis using Duralac MSDS anti-corrosion compound (A111C6017S) between the mating faces and inserting the appropriate shim stacks. Fit all fixing bolts and tighten evenly and progressively to a final torque of 45 Nm.

### AJ.4 - FRONT SUBFRAME

The front subframe uses the same construction techniques as the main chassis tub, with aluminium alloy extrusions bonded and riveted together to provide mounting points for the front suspension, front body clamshell and cooling radiators, and also houses the heating/a.c. system. The subframe legs are secured at each side to the front face of the chassis tub by three bolts, and reinforced by a tie plate on the outer surface which uses six bolts.

#### **To remove/refit front subframe**

Before removing the front subframe, it is recommended to remove all front bodywork, the front suspension assembly and the HVAC equipment in order to allow easier handling of the subframe and to minimise potential component damage.

1. Remove the front clamshell, 'A' panels and front bumper.
2. Recover the a.c. refrigerant and drain the engine cooling radiator. Remove the HVAC unit (see section PN) and disconnect all hoses, pipes, harnesses and cables.
3. Disconnect the steering column from the rack pinion shaft.
4. Provide support for the subframe before releasing the six bolts securing the tie plate to each subframe leg. Then progressively and evenly release the three bolts securing the inboard side of each subframe leg to the chassis. Withdraw the subframe.
5. On re-assembly, mate the subframe to the chassis and locate with the three bolts and each side. Fit the tie plates to the outboard faces and locate the six bolts at each side. Progressively and evenly tighten all 18 off M10x30 bolts to a final torque of 45 Nm.





**BODYCARE & REPAIR**

SECTION BU

	<u>Sub-Section</u>	<u>Page</u>
General Description	BU.1	3
Lotus Composite Body Features	BU.2	3
Bodycare	BU.3	4
Accident Damage Assessment	BU.4	5
Body Panel Bonding Materials	BU.5	6
Replacement of Bonded-On Panels - General	BU.6	9
Roof Panel	BU.7	9
Windscreen Frame	BU.8	10
Body Side Panels	BU.9	11
Rear Bulkhead	BU.10	12



1357

Evora Composite Body Panels

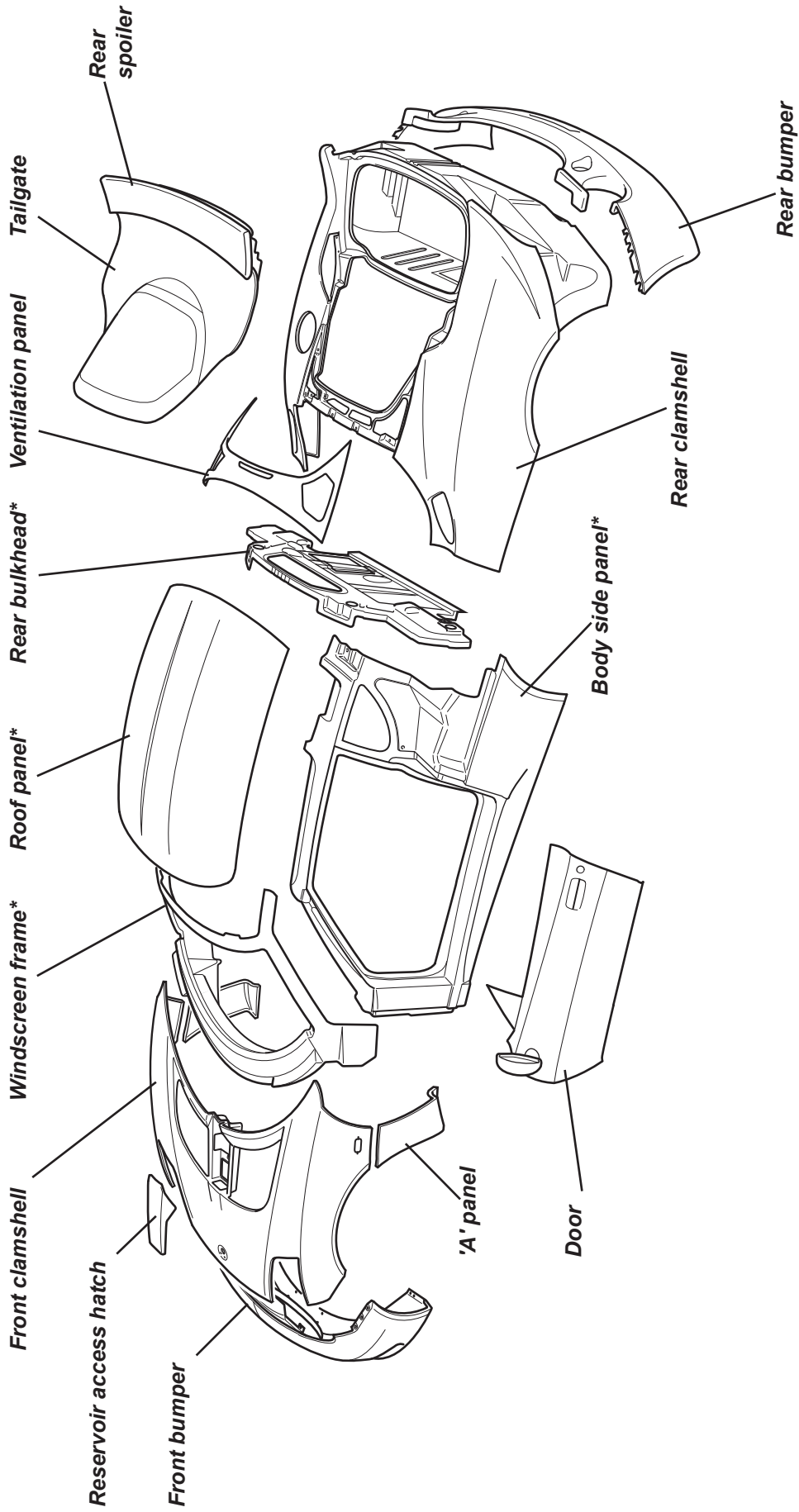

\* denotes panels bonded with elastomeric adhesive



### BU.1 - GENERAL DESCRIPTION

The body panels of the Lotus Evora are constructed of composite materials, and contribute to the overall stiffness of the body/chassis structure. The panels are attached to the aluminium chassis and/or other body panels either by elastomeric polyurethane adhesive, where maximum structural integrity is required, or by threaded fasteners, where ease of service access and repair is the greater priority. The windscreen frame incorporates foam cores to create closed box sections for optimum strength and lightness.

### BU.2 - LOTUS COMPOSITE BODY FEATURES

Composite structures have the ability to absorb high impact loads by progressive collapse, with impact damage being localised. In vehicle accidents this feature protects the occupants from injurious shock loads and greatly reduces the danger of entrapment by deformation of steel body panels. This behaviour also facilitates repair either by replacing the damaged bonded or bolt on panels, and/or integrating a replacement section with the undamaged area, using recognised approved methods which restore the panel to its original condition without residual strain or distortion.

The manufacturing process enables the thickness of composite mouldings to be varied in order to provide efficient structures of high strength and low weight. Composites will not corrode, so the strength of composite components is retained regardless of age, unless physical damage is sustained. On the Evora, the body construction features a safety cell around the cabin, comprising an assembly of body panels bonded to the chassis and to each other to provide maximum occupant protection combined with light weight. Both ahead of, and behind the cabin, body panels are screw fixed to permit easy removal for access to chassis or powertrain components, or to allow simple and economic accident repair.

A composite panel may return to its original shape after deflection, but beyond a certain level of flexibility, such treatment may result in the formation of surface cracks which may not be immediately apparent due to the masking effect of the paint film. A steel panel similarly treated would become dented or deformed. The cracking may be confined to the surface layer with no reduction in panel strength, but if the damage is more severe the composite structure below the surface may be weakened. Localised repairs can be made in either case. Possible causes of surface cracking include:

- Vehicle collision;
- Inappropriately sitting, leaning heavily or pushing on the body or any composite panel;
- Knocking doors against obstructions when opening;
- Dropping or striking objects against a panel, including footballs and other wayward missiles;
- Unrestrained items in the luggage compartment striking the inside of the rear body;
- Attempting to close the tailgate onto projecting luggage or tools
- Applying excessive force to parts attached to composite panels e.g. mirrors, handles and locks (inc. action by vandals).
- Incorrect jacking, or panel removal procedures.

The composite body panels of the Evora are manufactured by one of several processes dependent on the requirements of the panel concerned:

- All visible external panels, where surface quality is a priority, are produced by Injection Compression System Resin Transfer Moulding (ICSRTM), whereby glass fibre mat cut to shape and preformed when necessary, is placed in a heated, chrome steel surfaced, closed mould, into which polyester resin is injected. After filling, the gap between the two halves of the mould is then reduced in order to compress the moulding and ensure complete material flow and consistent structural quality. Panel thickness varies according to strength/weight requirement. The special 'low profile' resin used ensures minimum shrinkage during the curing process, in order to provide the optimum surface finish.
- For less visible components, including the rear bulkhead, battery box, boot box and some reinforcement panels, a Resin Transfer Moulding process is used with standard polyester resin injected at low pressure into a double sided closed tool containing dry and preformed composite material.
- For panels with a relatively simple shape and a low structural requirement, a Sheet Moulding Compound (SMC) process is used, whereby a pad of material impregnated with resin is placed in a closed tool which applies heat and a low compression to the moulding. A panel of high surface quality is produced, requiring only a minimum of fettling operations.





- The front and rear bumpers are produced by a Reinforced Reaction Injection Moulding (RRIM) process, whereby a mixture of polyurethane resin and milled glass is injected into a closed mould to result in panels with good surface finish and high flexibility.

Whichever production process applies, if repairs can be determined as being more economic than panel replacement, repair methods using either conventional composite techniques, or proprietary plastic component repair systems, can be used to rectify surface or structural damage.

### **ICS components**

Front clamshell outer  
Rear clamshell outer  
Bodysides  
Tailgate inner  
Roof  
Door inners  
Windscreen frame

### **RTM components**

Rear bulkhead  
Battery and boot boxes  
Clamshell reinforcement panels

### **SMC components**

Tailgate outer  
Door outers  
'A' post panels  
Reservoir access hatch

### **RRIM components**

Front and rear bumpers

## BU.3 - BODYCARE

The acrylic enamel paint finish of the Evora is extremely resistant to all normal forms of atmospheric attack. Following the simple maintenance procedure summarised below will help retain the gloss, colour and protective properties of the paint throughout the life of the vehicle. However, car finishes are not immune to damage, and amongst the more common causes of deterioration are:

- Atmospheric contaminants; dust, soot, ash, and acidic or alkaline aerosol mist can chemically attack paint.
- Abrasion; blowing sand and dust, or a dirty washing cloth.
- Tree sap and insect fluids; can form a water-insoluble polymer that adheres to the paint.
- Bird excrement; highly acidic or alkaline, they can chemically etch the paint. Wash off immediately.
- Leaves; contain tannic acid which can stain light finishes.
- Impact damage; granite chippings thrown up from poor or recently dressed road surfaces can subject the body to severe localised impact, and result in paint chips, especially around the vulnerable frontal panels.
- Moisture entrapment; Long term use of a non-breathable car cover can trap moisture and/or induce condensation and promote water penetration of the paint film.

### **Washing**

Lotus recommends hand washing of the painted bodywork. The car is a speciality sports vehicle not intended to be subjected to an automatic car wash. Automatic car washing machines may have a detrimental effect on the paint film and their use will invalidate the terms of the Vehicle Warranty.

Many contaminants are water soluble and can be removed before any harm occurs by thorough washing with plenty of lukewarm water, together with a proprietary car wash additive (household detergent and washing



up liquid can contain corrosive salts, and will remove wax and accelerate oxidation). Frequent washing is the best safeguard against both seen and invisible contaminants. Wash in the shade, and use a cotton chenille wash mitt or a sponge rinsed frequently to minimise entrapment of dirt particles. Use a straight back and forth washing motion to avoid swirled micro scratches, and rinse thoroughly.

In order to minimise degradation from road salt, the underside of the chassis should be rinsed with clean water as soon as possible after driving on treated roads. Many fuel filling stations offer pressure washing facilities ideal for this purpose, but to not use on the painted bodywork or vulnerable powertrain components or delicate radiator finning.

### Paintwork Polishing

Eventually some loss of gloss, and an accumulation of traffic film, will occur. At this stage, after normal washing, the application of a good quality liquid polish will restore the original lustre of the paint film. Higher gloss of the paint finish, and added protection against contamination, can be obtained by the use of a wax polish; however, this can only be used successfully on a clean surface, from which the previous application has been removed with white spirit or a liquid polish cleaner.

### Ventilation

Water lying on the paint surface for a lengthy period will eventually penetrate the paint film. Although the effects will not be visible immediately, a deterioration in the protective properties of the paint film will ultimately result. It is not recommended to store a wet car in a poorly ventilated garage. If good ventilation cannot be provided, storage outside on a hard standing or under a carport is to be preferred.

## BU.4 - ACCIDENT DAMAGE ASSESSMENT

The repair method to be employed in the rectification of accident damage to composite panels, is to be assessed relative to the particular panel and its method of attachment:

- Bolt-on Panels:
- Front Clamshell & Reservoir Hatch;
  - Front Bumper;
  - 'A' Panels;
  - Door Shells;
  - Rear Clamshell;
  - Rear Bumper;
  - Tailgate;
  - Ventilation Panel;
  - Reservoir Hatch.

These panels are secured by threaded fasteners and are easily removed for access to the back of any damaged area for repair by conventional composite techniques. Instructions for the removal and refitment of these panels are contained in section BV.

- Bonded-on Panels:
- Windscreen Frame;
  - LH & RH Body Side Panels;
  - Rear Bulkhead;
  - Roof Panel.

These panels are bonded to the chassis or to other panels using a flexible polyurethane adhesive which must be cut before the panel may be removed. In some cases, it may be necessary to partially remove another panel before the subject panel can be released. It is not generally economic to attempt to remove a bonded panel intact for later re-fitment.

The shape, positioning and structure of the windscreen frame is crucial to the fit of the windscreen and adjacent body panels, in addition to its behaviour in a vehicle collision. The only repairs which should be considered for this panel are cosmetic and superficial; any structural damage should be addressed by windscreen frame replacement.

The body side panels include the 'A' posts, 'B' posts and cantrails, and involve much labour time to replace. Localised repairs should be performed whenever possible, if necessary using a partial section cut from a replacement body side panel. Access to the inner surface should be considered when assessing cut lines.

Note that if damage is such as to require replacement of the chassis, a service replacement chassis is



provided only as a 'partial body assembly' which includes jig bonded windscreen frame, body side panels, rear bulkhead and roof. Also included, are the pipes, hoses and cables routed through the sills.

### BU.5 - BODY PANEL BONDING MATERIALS

The materials used for bonding the body panels are manufactured by Dow Chemical, and in order to maintain the structural integrity of the vehicle, and in the case of the front crash structure, the safety, it is most important to use only the specified materials. The surface preparation and cleaning and priming operations are crucial to the performance of the adhesive, and must be followed in detail. The products to be used depend on the surface (substrate) onto which they are applied, and the following list identifies each application:

#### *Anodised aluminium (e.g. chassis and components)*

Cleaner:	Betawipe VP 04604	Lotus part no. A082B6150V
Primer:	Betapnme 5404	Lotus part no. A082B6337V
Adhesive:	Betaseal 1701	Lotus part no. A082B6281F

#### *Unpainted or painted composite*

Cleaner:	Betaclean 3900	Lotus part no. A100B6008V
Primer:	Betaprime 5404	Lotus part no. A082B6337V
Adhesive:	Betaseal 1701	Lotus part no. A082B6281F

#### *Zinc plated and passivated steel*

Cleaner:	Betaclean 3900	Lotus part no. A100B6008V
Primer:	Betaprime 1707 (A+B)	Lotus part no. A111B6374V
Adhesive:	Betaseal 1701	Lotus part no. A082B6281F

#### *Glass*

Cleaner:	Betabrade F1	Lotus part no. A120B6043V
	or Betaclean 3300	Lotus part no. A120B6042V
	or Betaclean 3900	Lotus part no. A100B6008V
Primer:	Betaprime 5500	Lotus part no. A120B6041V
Adhesive:	Betaseal 1701	Lotus part no. A082B6281F

#### *Uncoated Lexan/Perspex*

Cleaner:	Abrasion & dry wipe	
Primer:	Betaprime 5404	Lotus part no. A082B6337V
Adhesive:	Betaseal 1701	Lotus part no. A082B6281F

#### *Residual adhesive (i.e. rebonding to surface after cutting off old panel)*

Cleaner, primer & re-activator:	Betawipe 4000	Lotus part no. A082B6355V
Adhesive:	Betaseal 1701	Lotus part no. A082B6281 F

#### **Applicator Bottle**

An applicator bottle is available for use with some cleaners and primers, and has a disposable felt pad which should be changed regularly to minimise surface contamination:

Applicator bottle:	A000Z1071F
Cap:	A082B6353S
Felt pad:	A082B6354S

#### **Product Usage**

BETAWIPE VP 04604 (A082B6150V):

Description: Activator and cleaning agent used to promote adhesion to the substrate surface. Supplied in a 250ml aluminium container with a YELLOW coloured cap.

Application: - Wipe on/wipe off type.  
- Pour Betawipe VP 04604 into applicator bottle, and immediately refit the yellow cap onto the



container.

- Push the applicator head onto the bottle, and fit the felt pad.
- Wet out the felt pan by inverting the applicator bottle and gently squeezing the sides.
- Wipe the pad over the substrate surface using minimal pressure to wet the surface.
- Immediately wipe off the activated/cleaned surface using a clean fibre free cloth, and discard.

- Notes:
- If the substrate is very dirty, first wipe off the surface with a clean fibre free cloth and discard.
  - Do not leave the caps off Betawipe containers. A milky colour indicates moisture absorption, and the material should be discarded.
  - Only decant a sufficient quantity of Betawipe for the job concerned, and never pour material back into the container from the applicator bottle.
  - Change the felt pad at regular intervals to reduce surface contamination.

#### BETACLEAN 3900 (A100B6008V)

Description: Degreaser and cleaning agent used for the removal of contamination from the substrate surface. Supplied in 1 litre aluminium container with a BLACK coloured cap.

- Application:
- Wipe on/wipe off type.
  - When substrate is very dirty, first wipe off the surface with a clean fibre-free cloth and discard.
  - Dampen a fibre-free cloth with Betaclean 3900, and immediately replace the black cap.
  - Thoroughly clean the substrate surface with Betaclean and discard the cloth.
  - Wipe off the substrate with a clean fibre-free cloth and discard.

#### BETABRADE F1 (A120B6043V)

Description: Liquid for removing contaminants from glass surface without scratching.

- Application: Betabrade F1 may be applied to either (i) the glass surface, or (ii) a fibre free cloth.
- Glass surface: Apply small beads of material, approx 3mm dia. x 50mm to the ceramic surface of the glass. Use a fibre free cloth to thoroughly clean the ceramic surface of the glass to be bonded and then wipe off all residual amounts. (A wipe on/wipe off process)
  - Fibre free cloth: Apply material to the fibre free cloth and thoroughly clean the ceramic surface of the glass to be bonded and then wipe off all residual amounts. (A wipe on/wipe off process)

#### BETACLEAN 3300 (A120B6042V)

Description: Cleaner for glass and ceramic frit (coating).

- Application: Betaclean 3300 may be applied to either (i) the glass surface, or (ii) a fibre free cloth.
- Glass surface: Spray the material onto the ceramic frit (coating) of the glass around the periphery and then using a fibre free cloth thoroughly clean the surface.
  - Fibre free cloth: Apply the cleaner to the fibre free cloth and then thoroughly clean the ceramic frit (coating). In both (i) and (ii) above the method is a wipe on/wipe off process.

#### BETAWIPE 4000 (A082B6355V)

Description: Cleaning agent which activates the old adhesive layer to accept new adhesive. Supplied in 15ml aluminium containers with a BLUE cap.

- Application:
- The residual adhesive bead should be cut with a scalpal to leave an even thickness of approximately 1 to 2 mm.
  - Dampen a fibre-free cloth with Betawipe 4000 and immediately replace the blue cap.
  - Thoroughly clean the substrate surface with Betawipe and discard the cloth. Do not wipe off.
  - Allow 2 - 3 minutes flash off time before applying adhesive.

#### BETAPRIME 5500 (A120B6041V)

Description: Adhesion promotor used to maximise the performance of the bonding between the cleaned and/or activated surface and the adhesive compound. Supplied in 250 ml aluminium container with GREEN coloured cap.

- Application:
- Two steel balls inside the container are provided to assist mixing of the contents when shaken.



Prior to decanting Betaprime 5500, shake the container for at least 60 seconds to disperse the solid content of the material into suspension.

- Pour the primer into the applicator bottle and immediately replace the green cap.
- Wet out the felt pan by inverting the applicator bottle and gently squeezing the sides.
- Wipe the pad over the activated/cleaned substrate surface to apply a continuous film of primer.
- Allow to dry for a minimum of 15 minutes before applying adhesive. If adhesive is not applied with 72 hours, wipe on/wipe off with Betawipe VP 04604.

Notes: - The appearance of the primed areas should be deep black in colour with no streaks or voids.

To achieve this appearance, apply in smooth continuous uni-directional movement, not short backward and forward movements. The latter technique results in inconsistent film build.

Rework any poor areas after 5 minutes (tack time), applying in the same direction.

- Replace the felt pad if moisture absorption results in hardening.
- Never return unused Betaprime back into the aluminium container.

## BETAPRIME 5404 (A082B6337V)

Description: Adhesion promotor used to maximise the performance of the bonding between the cleaned and/or activated surface and the adhesive compound. Supplied in 250 ml aluminium container with RED coloured cap.

Application: - Two steel balls inside the container are provided to assist mixing of the contents when shaken. Prior to decanting Betaprime 5404, shake the container for at least 60 seconds to disperse the solid content of the material into suspension.

- Pour the primer into the applicator bottle and immediately replace the green cap.
- Wet out the felt pan by inverting the applicator bottle and gently squeezing the sides.
- Wipe the pad over the activated/cleaned substrate surface to apply a continuous film of primer.
- Allow to dry for a minimum of 15 minutes before applying adhesive. If adhesive is not applied with 24 hours, re-activate by applying a further coat of Betaprime 5404.

Notes: - The appearance of the primed areas should be deep black in colour with no streaks or voids.

To achieve this appearance, apply in smooth continuous uni-directional movement, not short backward and forward movements. The latter technique results in inconsistent film build.

Rework any poor areas after 5 minutes (tack time), applying in the same direction.

- Replace the felt pad if moisture absorption results in hardening.
- Never return unused Betaprime back into the aluminium container.

## BETAPRIME 1707 A+B (A111B6374V)

Description: Adhesion promotor used to maximise the performance of the bonding between the cleaned and/or activated surface and the adhesive compound. Supplied in 250 ml aluminium containers of component A and component B.

Application: - Thoroughly shake component A container to disperse solid material. Remove the lid from the component A container and scrape any sediment from the bottom of the container. Replace the container lid and thoroughly shake again to disperse the solid content.

- Pour the required amount of component A into a clean container, and add the same volume of component B. Replace lids immediately. Thoroughly mix the two components for 45 seconds minimum.
- Leave the mixed components to stand for 30 MINUTES. (Discard if unused after 8 hours)
- Pour the primer into the applicator bottle and wet out the felt pan by inverting the bottle and gently squeezing the sides.
- Wipe the pad over the cleaned substrate surface to apply a continuous THIN film of primer: A thin, almost transparent film is all that is required. No attempt should be made to attain a completely opaque covering.
- Allow to dry for a minimum of 4 HOURS, before applying adhesive.

Notes: - To achieve a continuous thin film of Betaprime 1707, apply in a smooth continuous uni-directional movement, not short backward and forward movements. The latter technique results in inconsistent film build.



- Replace the felt pad if moisture absorption results in hardening.
- Never return unused Betaprime back into the aluminium container.

## BETASEAL 1701 (A082B6281F)

Description: One component moisture curing adhesive, providing high strength, permanently elastic bonds between various substrates. Supplied in 300 ml aluminium cartridge.

- Application:
- Remove the cartridge end ensuring there is no damage to the reinforcing sleeve.
  - Pierce the neck of the cartridge and screw on the applicator nozzle. Cut the nozzle end to the required diameter and shape.
  - Fit the cartridge into an air assisted gun, and extrude a smooth, even and continuous bead of Betaseal to the previously prepared substrate.
  - Assemble the joint within 5 MINUTES.

Notes: - If the adhesive has to be touched or manipulated for any reason, use only *wetted* fingers.

### Plastic Panel Repair System

For repairs of cracked or damaged panels 'in-situ', plastic panel repair systems may be used such as Wurth Replast, available under Lotus part number T000T1469F. Full instructions are supplied with the kit.

## BU.6 - REPLACEMENT OF BONDED-ON PANELS - GENERAL

Bonded body panels are secured using Dow Chemicals products 'Betaseal' or 'Betamate', which are flexible polyurethane adhesives which must be cut in order for a panel to be removed. The recommended method of adhesive cutting is with the use of a pneumatic tool such as are widely available from specialist tool suppliers, and which use a range of differently shaped cutting knives operating with a rapidly oscillating action. These tools may also be used to remove windscreens.

An applicator gun for dispensing Betaseal 1701 adhesive may be obtained directly from PC Cox Ltd, Turnpike Lane, Newbury, Berks. RG14 2LR Tel; +44 (0)1635 264500.

With some panels, it may not be practicable to attempt to removal intact for later refitment; damage to the bonding flange is likely to occur. Consequently, when expedient, the panel can be cut away for better access to the bonded joint. It is not necessary to remove all traces of sealant from the joint faces on the remaining panels or chassis, but any remaining sealant must be securely bonded and no thicker than 1 mm or the fit and joint gaps will be upset. It is essential always to follow the cleaning/priming/bonding operations meticulously if sufficiently strong and durable bonds are to be achieved. Always use the specified materials.

Preferred practice is to paint the body panels prior to bonding into position (as factory build), firstly masking off all bonding surfaces on the panel.

## BU.7 - ROOF PANEL

The composite roof panel is an ICS moulding which is last to be assembled, and generally the first panel which needs to be removed. The panel is bonded to the top of the windscreen header rail, cabin rear bulkhead panel, top flanges of the body side panels and seat belt mounting frame.

### To replace roof panel

1. Remove the 'A' post covers and the roof lining if this is to be re-used.
2. Remove rear clamshell (see sub-section BV.5).
3. Using a pneumatic knife or cutting wire, cut the adhesive between the roof and header rail, body side panels, rear bulkhead and seat belt frame, and remove the roof.
4. Remove excess sealant from all the bonding areas on the header rail, body side panels, rear bulkhead and seat belt frame. It is not necessary to remove all traces of old adhesive, but any remaining adhesive must be securely bonded and be cut with a scalpal blade to leave an even thickness of 1 - 2 mm.



5. Prepare the bonding surface of the new roof panel with Betaclean 3900 and Betaprime 5404 (see sub-section BU.5). Prepare the surface of the residual adhesive on the body panels and seat belt frame using Betawipe 4000 (see sub-section BU.5).
6. Apply a bead of Betaseal adhesive (see sub-section BU.5) to the bonding surface on the header rail, rear bulkhead, body side panels and seat belt frame, and fit the roof into position. Press all around the whole length of the joint to ensure sufficient spread of adhesive, if necessary using a spatula to smooth or remove any extruded adhesive, and to neaten any visual areas. Where necessary, add adhesive to the jointline to ensure complete weathersealing and neat appearance, and smooth with a spatula.
7. Clamp the panel into position until the adhesive has cured (see sub-section BU.5).
8. Refit displaced parts as necessary.

### BU.8 - WINDSCREEN FRAME

The windscreen frame is an assembly of ICSRTM mouldings featuring hollow, foam filled sections, and including a screen bottom landing panel, the two windscreen pillars and the windscreen header rail. The landing panel is bonded to the chassis scuttle, the pillars to the body sides, and the roof panel bonds to the header rail.

Localised damage to the frame should be repaired *in situ* using recognised techniques, but it is unlikely that the complete frame will require replacement without the body sides and/or roof panel also being damaged. Replacement of the windscreen frame will in any case require that the roof panel be removed, and the front section of both body sides be released from the chassis.

The elastomeric adhesive bonding the frame to the scuttle and other body panels requires cutting with a reciprocating knife, if necessary cutting the frame itself to allow improved access to the joint. It is unlikely to be economic to attempt to remove a windscreen frame for re-fitment.

#### **To replace windscreen frame**

1. Remove the front clamshell (see sub-section BV.4) and wiper mechanism.
1. Remove the front clamshell, windscreen pillar trims, fascia top panel and headlining.
2. Remove the wiper mechanism and cut out the windscreen (see sub-section BV13).
3. Remove the roof panel (see sub-section BU.10).
4. Cut the adhesive securing both body sides to the chassis 'A' posts.
5. Remove the bracket securing the frame to the pedal box.
6. Cut the adhesive bond securing the frame to the chassis and to the body side panels, and remove the frame from the car.
7. Prepare the old adhesive bead on the chassis and any existing body panels for fitment of the new windscreen frame by removing excess sealant from all the bonding areas to leave a consistent and level bonding surface for the new frame. It is not necessary to remove all traces of old adhesive, but a uniform surface must be available for the new adhesive bead. Any remaining adhesive must be securely bonded and be cut with a scalpal blade to leave an even thickness of 1 - 2 mm.
8. If necessary, replace the foam sealing blocks between scuttle and frame using Betaseal products to clean, prime and bond new blocks into position on the chassis.
9. - Prepare and re-activate the old adhesive bead on the chassis and other components using Betawipe 4000 (see BU.5).  
- Clean and prime the bonding area on the new windscreen frame with Betaclean 3900 and Betaprime



5404 (see sub-section BU.5).

- Apply a bead of Betaseal 1701 adhesive (see sub-section BU.5) to the whole of the chassis bonding flange on the windscreen frame, and to the body side panel flanges.
- Spring the body sides apart sufficiently to allow careful positioning of the windscreen frame onto the chassis and locate with the tie bracket to the pedal box.
- Mate the body sides to the 'A' posts and windscreen frame.
- Press around all bonded joints to ensure adequate adhesive compression. Ensure the windscreen frame is positioned correctly by measuring from the underside of each top rear end of the frame to the top surface of the chassis siderail. Specification = 744mm. Compare diagonal dimensions to verify squareness. Support the header rail in this position to prevent drooping until the adhesive cures.
- Ensure complete bonding between the frame and scuttle/foam blocks/other body panels, with no gaps, if necessary extruding more adhesive into the joint.
- Use a spatula to smooth out or remove any excess adhesive, leaving a neat appearance, especially where the joint will be visible.

10. Do not disturb the frame until the adhesive has fully cured (see sub-section BU.5).
11. Fit the windscreen (see sub-section BV.13), dash panel (BV.12), front clamshell (BV.4), and other components as necessary.

### BU.9 - BODY SIDE PANELS

Each body side panel incorporates the complete sill section, lower rear quarter panel ahead of the rear wheelarch, 'A' and 'B' posts, door aperture and rear quarter window aperture. The panel is bonded to the chassis, windscreen frame, rear bulkhead panel and roof.

The sill bottom flange is bonded into a groove in the chassis main side rail and it is necessary to cut the panel to effect its removal: it is not practical to attempt to remove a body side panel intact for later refitment. If damage occurs to the panel which is not repairable 'in situ', the body side panel should be renewed. However, in view of the extensive amount of labour required to replace a body side, localised repairs or integrated sections should be considered wherever possible.

#### **To replace body side panel**

1. Remove front and rear clamshells (see sub-sections BV.4, BV.5), doors (BV.8) and roof panel (BU.10).
2. Remove electrical equipment fixed to the inside of the body side in the rear quarter area.
3. Remove the door weatherstrip seal and door latch striker plate.
4. Use a sealant cutting knife to cut the adhesive bead between body side and chassis, windscreen frame and rear bulkhead. Also cut the adhesive around the door hinge faces, the striker plate face and the seat belt mounting frame.

#### **Note:**

- The bottom edge of the sill locates in a groove in the chassis side frame, and may not readily be cut out with the sill intact. Cut the sill as necessary to release the panel, and then remove the remaining edges of the panel from the chassis using a suitable cutting knife.
5. Remove excess sealant from all the bonding areas on the chassis and body panels. It is not necessary to remove all traces of old adhesive, but any remaining adhesive must be securely bonded and be cut with a scalpal blade to leave an even thickness of 1 - 2 mm.
  6. Dry fit the body side panel and fettle if necessary to achieve a good fit.
  7. Before preparing the surfaces for bonding, ensure that the necessary pipes and cables are fitted to the chassis side rails and are in good condition:





- RH side:
- Engine radiator return pipe
  - A.C. feed and return pipes
  - PAS feed and return pipes
  - Right hand rear brake pipe
- LH side:
- Engine radiator feed pipe
  - Heater feed and return pipes
  - Clutch pipe
  - Brake servo vacuum pipe
  - Positive battery cable to front post.

Check also, by comparison with the displaced part, that the 'B' post reinforcement panel, and all necessary bonded brackets and captive fixings, are correctly attached to the new sill panel.

8. Prepare the bonding surface of the new body side panel with Betaclean 3900 and Betaprime 5404 (see subsection BU.5). Prepare surface of the old adhesive bead on the chassis and body panels Using Betawipe 4000 (see sub-section BU.5).
9. Apply a bead of Betaseal adhesive (see sub-section BU.5) to the bonding surface on the chassis, windscreen frame and rear bulkhead, and fit the body side panel into position, first locating the sill bottom edge into its chassis slot. Press all around the joint and ensure sufficient spread of adhesive, if necessary using a spatula to smooth or remove any extruded adhesive, and to neaten any visual areas. Where necessary, add adhesive to the jointline to ensure complete weathersealing and neat appearance, especially around the door hinge post apertures, and smooth with a spatula.
10. Clamp the panel into position until the adhesive has cured (see sub-section BU.5).
11. Refit the dash panel, front and rear clamshells, doors, both wheelarch liners and other components as necessary.

## BU.10 - REAR BULKHEAD

The rear bulkhead is a Resin Transfer Moulded (RTM) panel and is bonded to the chassis and seat belt mounting frame. The roof panel is bonded to its top flange, and the body side panels to each side flange.

A heat formed polyester fibre heat/acoustic insulator panel is bonded to the rear side of the panel. The cabin rear window is bonded directly to the bulkhead using the same materials and procedure as is used for the windscreen. A screw fixed panel is provided on the right hand side to allow access from the cabin to the alternator, compressor and adjacent engine components.

Replacement of the complete bulkhead panel is unlikely to be required without a complete body rebuild. In the case of localised damage, the panel should be repaired *in situ* using conventional hand lay techniques, if necessary integrating a new section cut from a new bulkhead panel. The position of the rear bulkhead is critical to the fit of the tailgate and rear body section. If building up a new chassis tub, a jig assembled bulkhead and rear seat belt mounting frame should be used, as a 3 - 5 mm standoff is required between the panel and frame.

*Rear Window:* In order to minimise noise and heat transmission into the cabin, the rear bulkhead window is a double glazed unit comprising two 4mm, toughened, clear, flat glass panes, separated by a 6mm void filled with Argon gas. An obscuration band is applied to the rear face of both panes, with identification data read from the engine bay side. The unit is bonded to the front face of the rear bulkhead panel using materials supplied by Dow Chemical.

To replace the glass, remove the rear bulkhead trim and use a reciprocating knife to cut the bonding medium. Clean the whole of the bonding surface on the new glass with Betawipe VP 04604 (yellow cap), and prime with Betaprime 5500 (green cap). Clean the corresponding surface on the bulkhead with Betaclean 3900 (black cap) and prime with Betaprime 5404 (red cap). Apply a bead of Betaseal 1701 to the periphery of the glass, and press into position on the bulkhead to ensure sufficient and uniform compression of the adhesive. Use a spatula to remove excess extruded adhesive and smooth any visual areas. Support the glass in place as necessary until the adhesive has cured sufficiently.



*Bonding of rear bulkhead:* The rear bulkhead panel is positioned by reference to the rear seat belt mounting frame, and should be fitted only as a jig built assembly of bulkhead and frame.

Clean the mating surface on the bulkhead with Betaclean 3900 (black cap) and prime with Betaprime 5404 (red cap) or, where applicable, use Betawipe 4000 to re-activate old adhesive (refer to sub-section BU.5). Clean the mating surface on the chassis with Betawipe VP 04604 (yellow cap), and prime with Betaprime 5404 (red cap), or with Betawipe 4000 to re-activate old adhesive. Apply a bead of Betaseal 1701 to the bonding path on the chassis, and fit the bulkhead/frame assembly into position by securing the frame with its four bolts to the extruded brackets which form part of the chassis tub. If necessary, apply additional adhesive into the joint and use a spatula to remove any excess extruded adhesive and to smooth any visual areas.

The rear bracing struts should then be shimmed as necessary to avoid corrupting this position. The stays connecting to the front seat belt mounting frame should then be similarly shimmed.



**BODY FITTINGS**

**SECTION BV**

	<u>Sub-Section</u>	<u>Page</u>
General Overview	-	2
Reservoir Access Hatch	BV.1	3
Tailgate	BV.2	3
'A' Panels	BV.3	4
Front Clamshell	BV.4	5
Front Bumper	BV.5	5
Rear Clamshell	BV.6	6
Rear Bumper	BV.7	8
Door Mirrors	BV.8	9
Door Shell, Beam & Hinges	BV.9	10
Door Weatherstrip Seals	BV.10	11
Door Window, Guide Rails & Lift Mechanism	BV.11	12
Door Latch Mechanism	BV.12	14
Windscreen Removal/Replacement	BV.13	15
Tailgate Glass	BV.14	17
Cabin Rear Window	BV.15	18
Rear Quarter Light Window	BV.16	18



B357

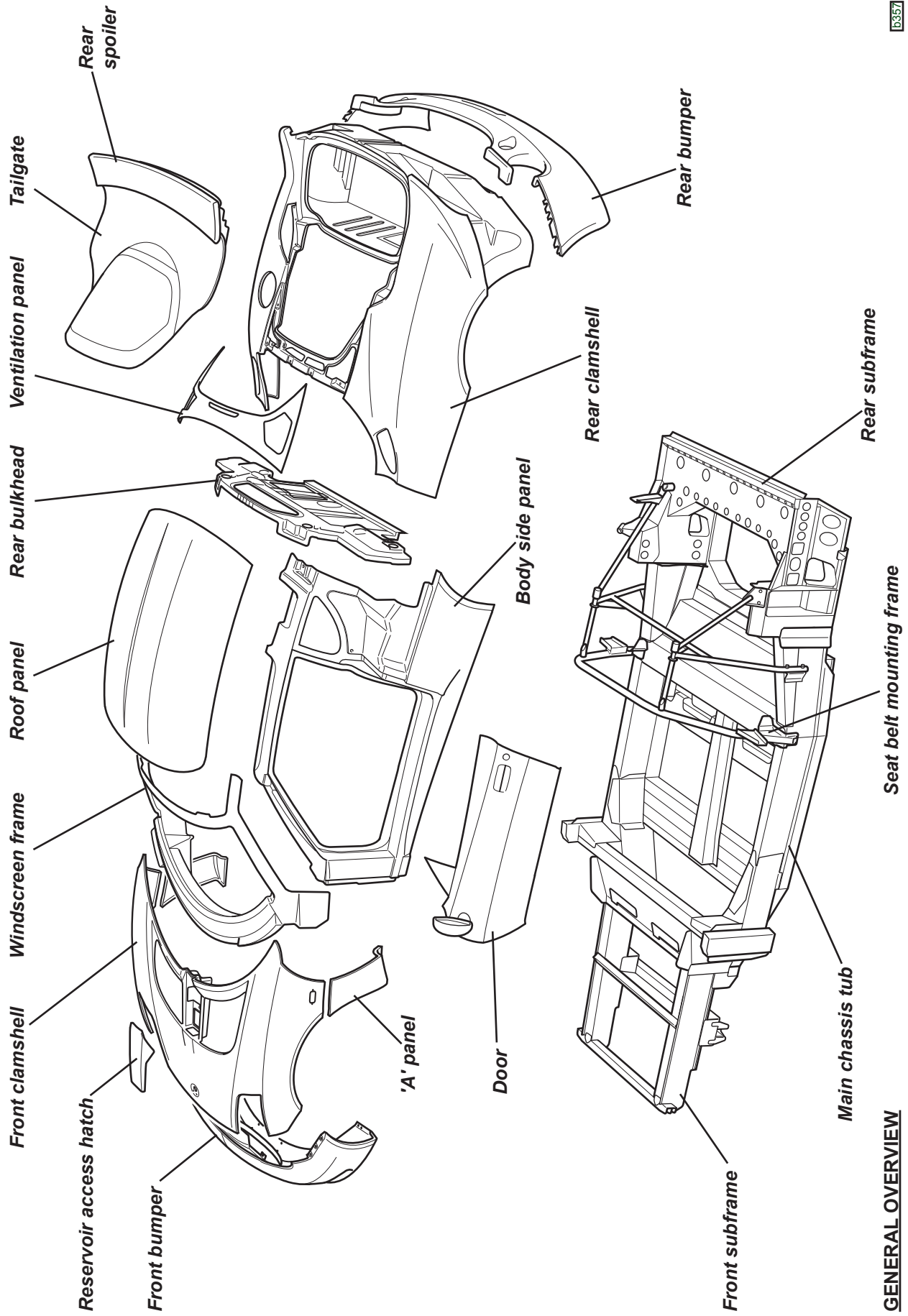

**GENERAL OVERVIEW**



## BV.1 - RESERVOIR ACCESS HATCH

The Lotus Evora is fitted with a front hinged, composite, access hatch in the front body to provide ready access to the brake/clutch master cylinder reservoir and windscreen washer reservoir filler neck. Incoming air to the interior climate pollen filter is also routed through this area from the high pressure zone at the base of the windscreen.

To open the hatch, from the inboard side of either footwell, press down the release lever; the hatch may then be raised fully by hand.

Before closing, check that the reservoir caps are secure, lower the lid, and press firmly over the latch.

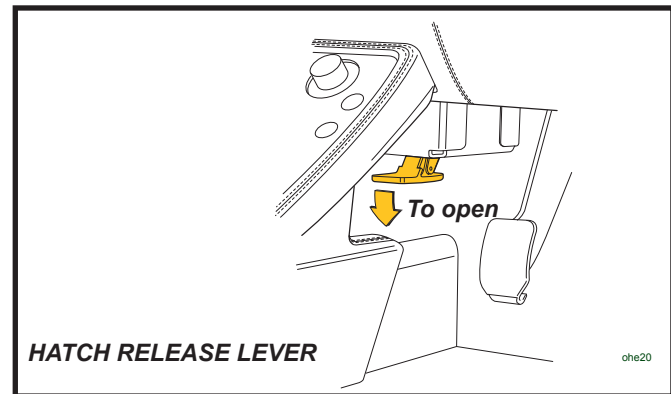

### **Access panel adjustment**

The hinge stator is secured by two M6 nuts to a captive studplate on the clamshell, with sufficient hole tolerance to allow some adjustment of panel height. Similarly, the hinge rotor is secured by 2 M6 nuts to a studplate in the cover, with allowance made for adjustment of shutlines.

## BV.2 - TAILGATE

The composite tailgate panel is hinged at its leading edge to the rear bulkhead, and uses a single latch mounted centrally at its rear end. The latch is released by an electric solenoid activated by the transmitter key fob, but note that unlatching is inhibited with the ignition switched on. An emergency release is provided in the form of a mechanical cable from a handle concealed beneath the rear seat cushion (or carpet). Opening of the tailgate is assisted by a pair of gas pressurised struts. The tailgate incorporates a heated window glass, and, to the rear of the glass, an outlet grille for hot air from around the rearmost catalytic converter.

The extruded alloy hinge arms are bolted to the tailgate with two M8 screws and reach beneath the ventilation panel to the cabin rear bulkhead, to which the hinge stators are secured with two M8 screws. The steel hinge pin is an interference fit into the stator, and supports two top hat synthetic bushes pressed into the bore of the hinge rotor, with an 'E' clip used for retention. Oversize hinge fixing holes allow for the adjustment of tailgate panel shutlines.

Pivot ball pins for the twin gas struts are screwed into captive nuts in the tailgate inner panel, with the lower end of each strut anchored to a steel bracket secured to the clamshell aperture. A spring steel clip secures each strut pivot socket onto its ball pin.

The latch mechanism is secured to the tailgate, and the striker hoop to the clamshell, with a security system sensing switch incorporated into the latch. The latch release solenoid is mounted to the right of the striker, and uses a short link to pull a bellcrank lever pivoted on the striker, and interacting with a release lever on the latch mechanism. The manual release cable activates the same bellcrank lever, and is routed over the RH wheelarch and through the cabin bulkhead. An adjustable height downstop buffer is provided at each rear corner of the tailgate for panel height alignment and stability.

The rear aerofoil is secured to the tailgate with 2 x M6 button head screws at each side, and houses the CHMSL, which comprises 12 red LEDs behind a white diffuser. The CHMSL wiring combined with the latch sensing switch and HRS wiring, form a tailgate harness which exits the tailgate inner skin near the RH hinge, to which it is clipped before penetrating the cabin bulkhead.

The heated, toughened glass screen with pre-applied obscuration band, is bonded to the tailgate with an elastomeric adhesive (see sub-section BV.14).

### **Tailgate remove/refit**

To remove the tailgate:

1. Disconnect the tailgate harness at the RH hinge area.
2. Release the spring clip securing each gas strut to the tailgate and disengage the struts.



3. Scribe around the hinge blade on the tailgate to aid refit alignment (if applicable) before supporting the tailgate and removing the hinge blade fixing bolts.
4. Refit in reverse order to removal, adjusting panel shutlines and height as necessary. Check latch engagement and release, and adjust striker position if necessary.

**BV.3 - 'A' PANELS**

Each 'A' panel constitutes the body surface below the waistline between the front wheelarch and the door aperture, with each panel screw fixed to the front clamshell and body sill.

**'A' panel removal/replacement**

1. Slacken or remove the front wheelarch liner and release the two screws securing the 'A' panel to the rear lower flange of the front clamshell.
2. Slacken or remove the two screws securing the bottom edge of the panel to the body sill and withdraw the panel.
3. Replace in reverse order to removal.

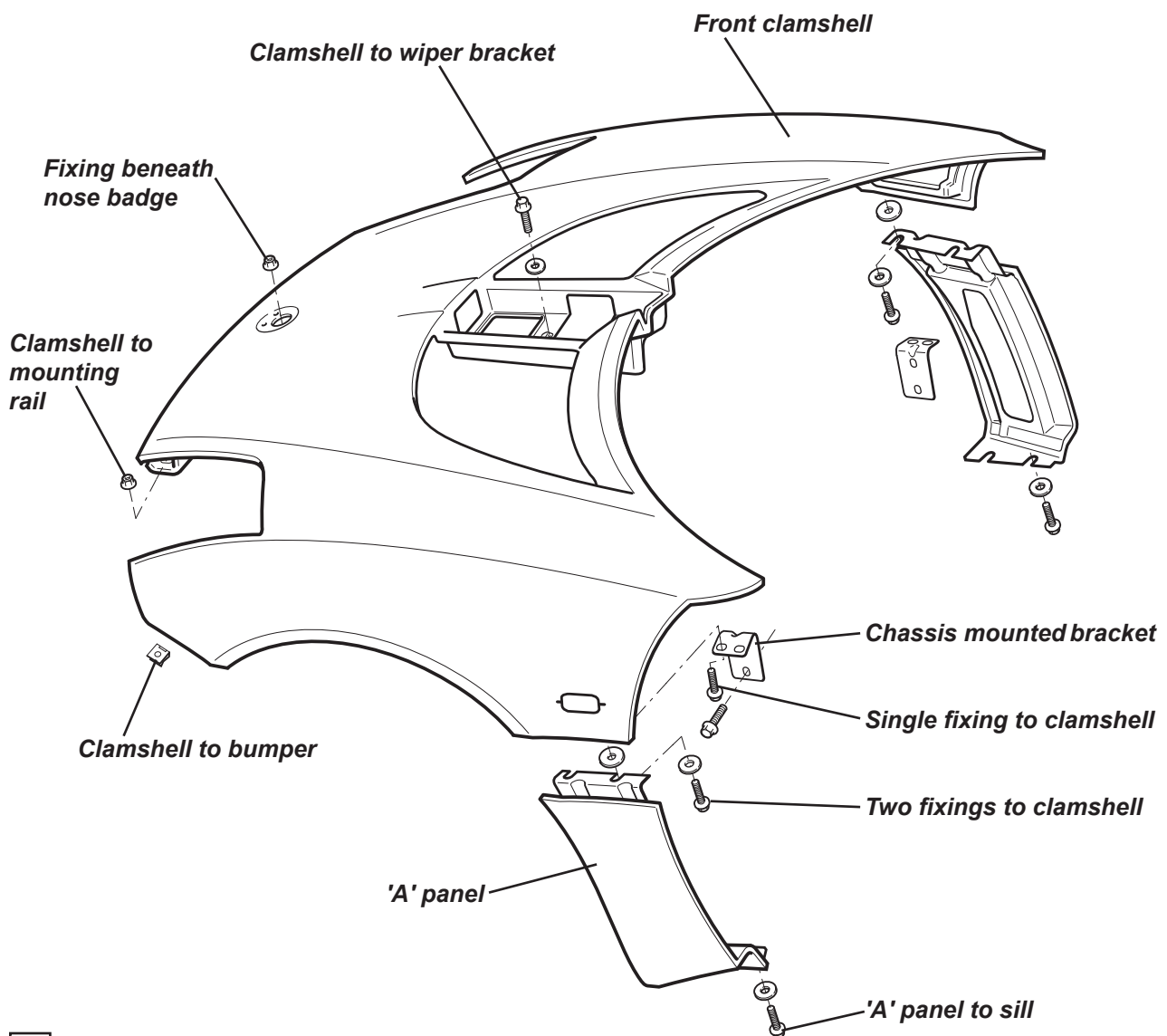

b358



### BV.4 - FRONT CLAMSHELL

The front clamshell comprises a composite moulding forming the front upper bodywork between the base of the windscreen and the front bumper. Incorporated into the panel are apertures for the radiator air outlet grilles, and a recess for the hydraulic fluid and windscreen washer reservoirs. The panel is secured by threaded fasteners for ease of access to the HVAC and engine cooling radiator, and to allow economical panel repair or replacement. The panel is secured to the front subframe via mounting brackets, and to the front bumper and 'A' panels, with provision being made for height and shutline adjustment.

#### **Front clamshell removal/replacement**

The clamshell with front access panel may be removed whilst leaving the front bumper in position:

1. Remove both front wheels and wheelarch liners.
2. Open the reservoir access hatch, remove the three screws securing the latch, and disconnect the release cable. Feed the cable through the clamshell grommet. Release the two fixings securing the hydraulic fluid reservoir to the clamshell, and the two screws securing the washer reservoir filler neck. Release the washer tube and harness connector from the washer jet.
3. From within each wheelarch, disconnect the headlamp harness and headlamp washer tubing. Release the two fixings securing the headlamp front mounting bracket to the subframe, and the two fixings securing the headlamp rear bracket to the bumper support bracket. Withdraw the headlamp.
4. From within the front of each wheelarch, release the three fixings securing the clamshell to the top edge of the bumper.
5. From within the back of each wheelarch, release the two fixings securing the clamshell to the top of the 'A' panel, and the single screw to the chassis bracket. Disconnect the side repeater lamp.
6. From the headlamp apertures, release the two nuts at each side, securing the front edge of the clamshell to the mounting rail.
7. Prise out the nose badge taking suitable precautions to avoid paint damage. From the access hole revealed, remove the single fixing securing the clam to the mounting rail.
8. Carefully lift the clamshell from the car and place on a protected surface.
9. Refit in reverse order to removal, noting that all fixing points incorporate provision for adjustment of panel height and alignment via slotted holes or shim washers. The height of the clamshell front fixing rail is adjustable against the subframe at the three slotted fixing points on the rear face, accessible via the headlamp apertures. Clamshell adjustments must be completed before the headlamps are fitted and adjusted to seal correctly against the clamshell apertures.
10. Check headlamp beam alignment.

### BV.5 - FRONT BUMPER

The front bumper may be removed with the clamshell in place, but the headlamps must be removed to provide access to the upper fixings.

1. Remove both front wheels and wheelarch liners. At each side, disconnect the headlamp harness and headlamp washer tubing. Release the two fixings securing the headlamp front mounting bracket to the subframe, and the two fixings securing the headlamp rear bracket to the bumper support bracket. Withdraw the headlamp.

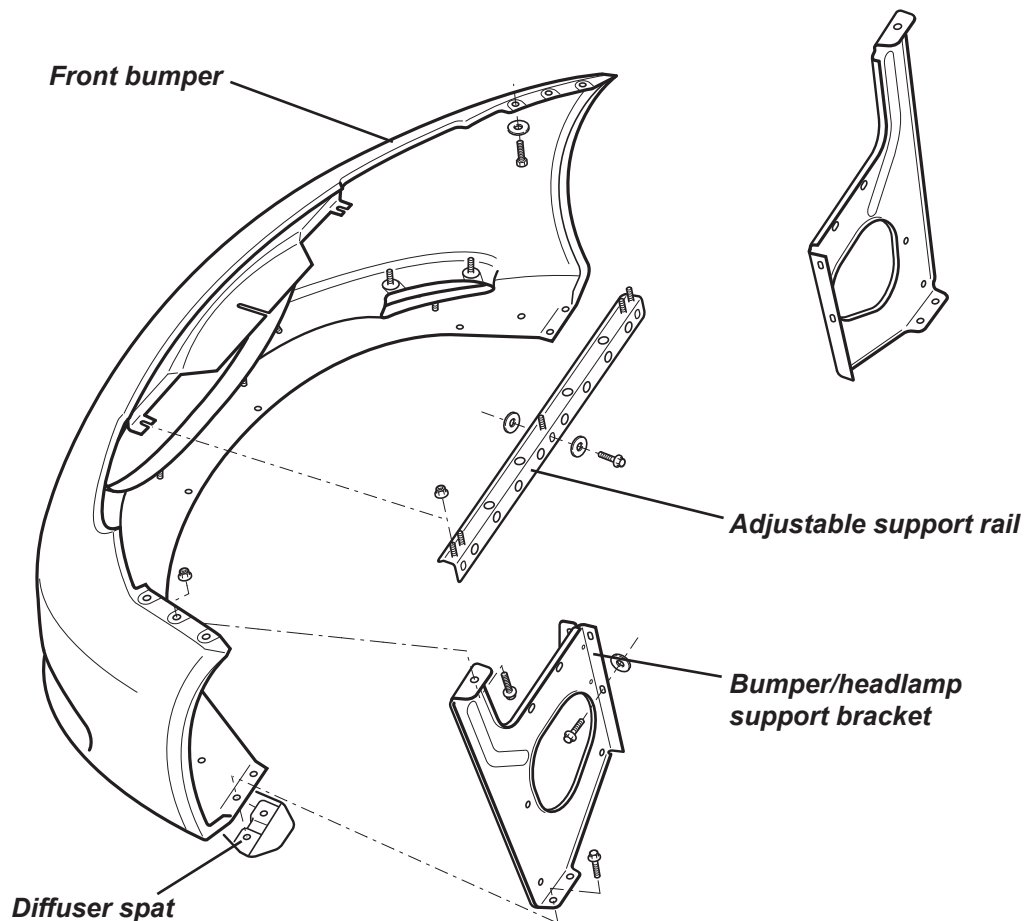

2. From each headlamp aperture, release the three fixings clamping the bumper top flange to the clamshell and to the support bracket.
3. From each headlamp aperture, slacken the two nuts securing the front edge of the clamshell and bumper top flange to the support rail. Prise out the nose badge taking suitable precautions to protect the surrounding paintwork, and slacken the single nut securing the centre of the clamshell and bumper.
4. From beneath the car, release the fixings securing the front undertray to the lower edge of the bumper, and the two screws securing each lower rear corner of the bumper to the support bracket.
5. Withdraw the bumper.
6. Ensure the bumper foam is fitted to the subframe before replacing the bumper in reverse order to removal, inserting the top flange between the clamshell and support rail.

BV.6 - REAR CLAMSHELL

The rear clamshell comprises the principal body moulding aft of the doors and includes the integral boot box. The separate rear bumper panel is screw fixed to the rear face of the clamshell. The front of the clamshell is secured to the body side mouldings and the back edge of the roof panel, with the back end supported via the boot floor to the rear subframe. The tailgate hinges reach beneath the top edge of the clamshell to fix onto the rear bulkhead, such that the tailgate needs to be removed before the clamshell may be released. The rear bumper may remain fitted to the clamshell. Two people are required to lift the clamshell from the vehicle, and sufficient space provided to store the panel without paint damage.



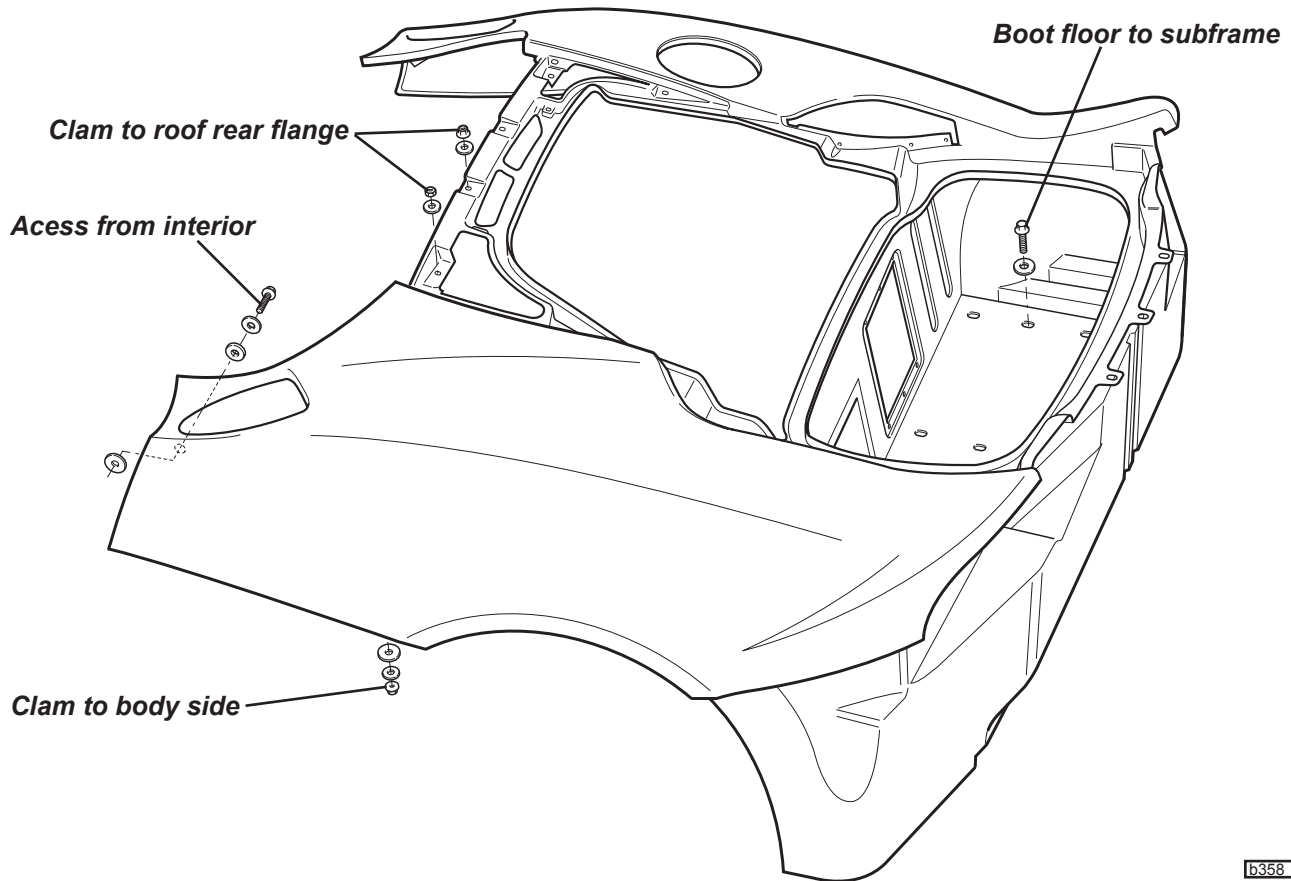

b358

**Rear clamshell removal/replacement**

1. Tailgate: Remove the tailgate (see BV.2), both rear wheels, and wheelarch liners.
2. Ventilation panel: The engine bay outlet ventilation panel around the top edge of the tailgate aperture needs to be removed to provide access the clamshell to roof fixings.
  - From beneath the clamshell aperture, release the 2 fixings securing the vent panel to the roof rear flange, and one at each side fixing to the body side panel.
  - Draw the panel rearwards and lift to release from the keyhole slot at each front corner.
3. From the access provided by op. 2, remove the two nuts securing the clam to the roof rear flange, and the single nut to each body side panel.
4. Battery: Remove the battery cover, battery and tray, and feed the two battery cables out through the clamshell grommets.
5. Boot box: From inside the boot, release the 8 fixings securing the boot floor to the subframe, and the 4 fixings in the boot front wall securing the heatshield. Release the single screw securing the header tank bracket to the boot wall.
6. Wheelarch: From within the front of each rear wheelarch, release the fixing securing the clamshell to the body side top flange. Reach further forward with an M10 socket and short ratchet handle to release the similar fixing at the front of this flange.
7. Remove the fuel cap and pull the grommet over the filler neck. Re-seal the neck. Unplug the flap release solenoid connection.
8. At the back of each wheelarch, release the two fixings securing the clamshell to the subframe bracket, and the 2 fixings to the diffuser panel.



9. At each side, release the front seat belt upper anchorage from the 'B' post, and pull off the 'B' post top trim. Pull the weatherstrip seal off the body vertical flange at the rear of the door aperture. Pull the rear quarter trim panel away at its top edge to release the two spring fasteners beneath the quarter window. This should allow sufficient access to the single M8 headed screw securing the topshell to the body side just below the front end of the rear quarter window.
10. Unplug the rear harness at the RH side of the boot and feed the harness through the panel. Unplug the cable to the reversing camera and withdraw the cable through the clamshell. At the left hand side of the boot, disconnect the parking sensor module and tyre pressure monitoring harnesses and feed through the clamshell.
11. Carefully lift the clamshell from the body and lay aside on a protected surface. Note and retain any shim washers or plates used at each fixing point.
12. Refit the clamshell in reverse order to removal, taking appropriate precautions to protect surfaces from damage during the installation process. Refit any shim washers or plates noted on disassembly. Assess shutlines and panel heights as early as possible and amend shim stacks as necessary.

## BV.7 - REAR BUMPER

The rear bumper moulding is screw fixed to the rear face of the rear clamshell, and covers the impact foam secured to the rear subframe. It also incorporates the rear transom panel, houses the licence plate lamps and rear fog and reverse lamps, and mounts the diffuser finisher.

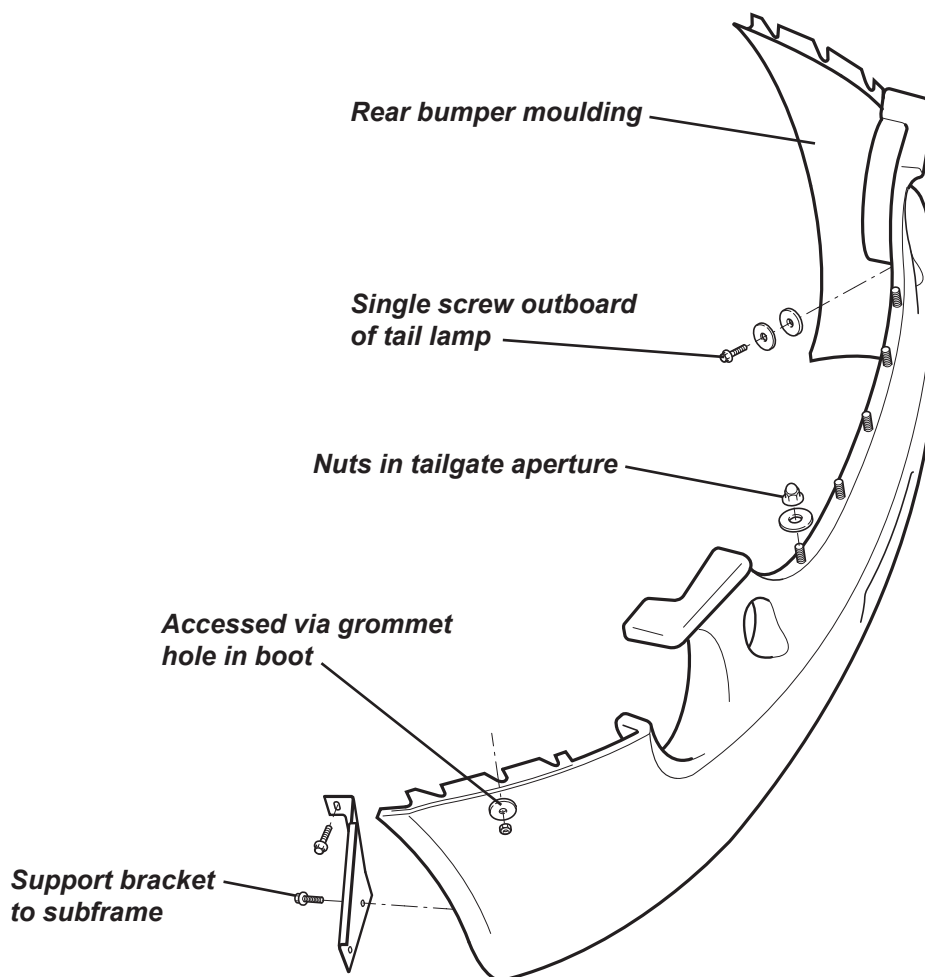

b359

**To remove/refit rear bumper**

1. From inside the boot, remove the trim panel from around the latch mechanism, and disconnect the harnesses to the rear fog and reverse lamps, parking sensors and reverse camera.
2. From within each rear wheelarch, release the single fixing securing the lower edge of the bumper to the subframe bracket, and the two fixings at each side securing the diffuser finisher to the diffuser. Also release the single fixing securing the top edge of the bumper to the clamshell flange.
3. From within each side of the boot, remove the two grommets, and release the two fixings securing the bumper top edge to the clamshell. Also remove the single screw just outboard of the tail lamp.
4. Remove the 5 fixings along the rear edge of the boot aperture, clamping the bumper to the clamshell.
5. Carefully withdraw the bumper from the clamshell.
6. Refit the bumper in reverse order to removal, adjusting the panel heights and gaps as necessary.

**BV.8 - DOOR MIRRORS**

The two door mirrors are electrically adjustable, and, only when the engine is running, are heated on demand in conjunction with the HRS for a maximum period of 10 minutes. An optional specification includes an electric fold facility for use when parking or negotiating narrow gaps.

Each mirror comprises a cast alloy bracket carrying a black textured plastic housing, and a gimbal mounted glass carrier driven by a pair of electric motors, and to which is attached the mirror glass. A third motor provides the fold function. A sprung attachment of the mirror housing to the plinth allows the mirror to move forwards or backwards on accidental contact, in order to reduce the potential for personal injury or vehicle damage. A body colour painted moulding is clipped to the front of the mirror housing.

This mirror assembly is mounted via a cast alloy plinth to the door cheater panel, with upper and lower black plastic mouldings used for cosmetic enhancement.

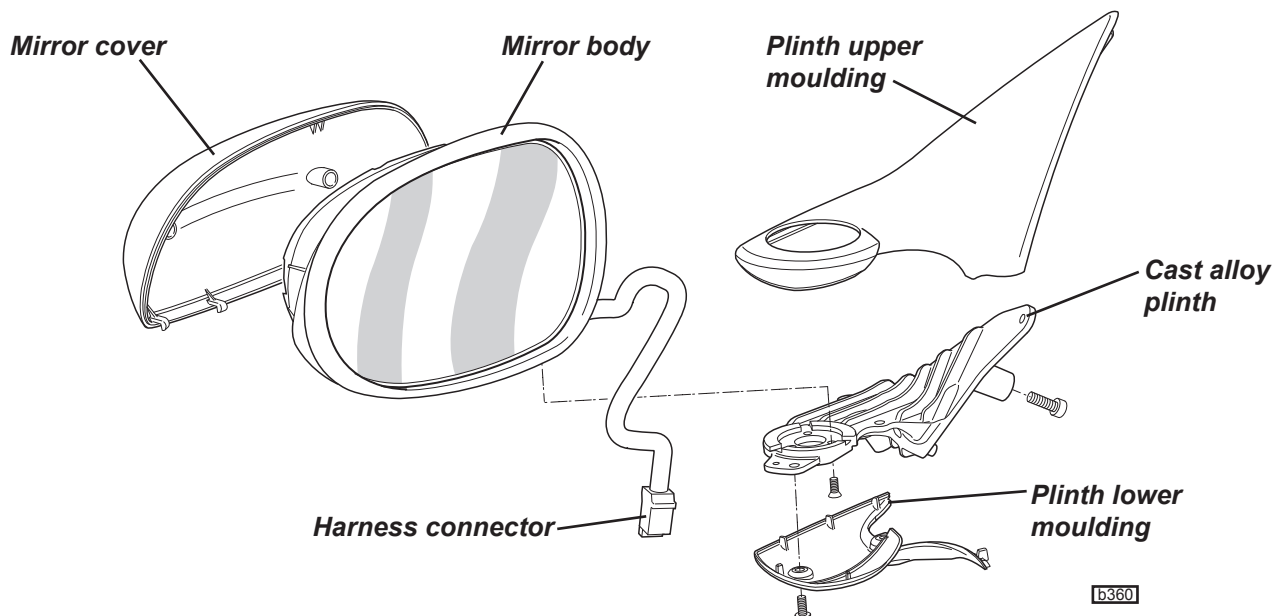
**Replacement of mirror glass and cover**

The mirror glass is contained in a plastic carrier which includes the heating element and terminals. To remove the glass, press the glass so as to expose the outer edge, and carefully ease the outboard end from its carrier clip. Then unhook the inboard end, unplug the two heater cables, and remove the glass. Check that the adjustment racks have not become detached from the gimble during disassembly.



To refit, connect the cables (either way round), hook on the inboard end of the glass carrier, and press the outboard end until the clip is engaged.

Note that convex glass is normally fitted to both sides in order to provide the widest field of vision, but certain markets use flat glass on one or both sides. Be aware that objects viewed in convex mirrors appear more distant than when viewed with flat glass.

The painted cover is secured to the mirror body by integrally moulded clips. To remove a cover, first remove the glass to allow the lower clips to be eased, whilst the lower edge of the cover is carefully prised away.

**Replacement of mirror assembly**

To remove the complete mirror, the assembly of mirror, plinth and covers must be released from the door:

1. Remove the door trim panel (see sub-section VE.2).
2. Unplug the mirror harness connector, remove the split grommet and back feed the harness into the door shell. Use the harness hole to access and remove the mirror plinth lower fixing screw.
3. Remove the Rokut plastic rivets securing the plinth upper finisher and cheater panel seal to the door. Pull back the cheater seal to access and remove the plinth upper fixing screw.
4. Withdraw the mirror assembly whilst feeding the harness through the door shell.
5. Remove the plinth lower cover by releasing the two retaining screws.
6. To allow the mirror to be removed from the plinth, the connector block must first be removed. Record the cable colour against connector cavity before using a suitable terminal extractor tool to depress the retaining barb, and withdraw each terminal from the connector. Remove the three screws around the pivot mechanism and withdraw the mirror from the plinth.  
Note that the plinth upper finisher is heat bonded to the plinth. If necessary, new parts can be mated using a soldering iron or similar to secure.
7. New mirror assemblies may be supplied with an unsuitable connector block. Use an appropriate terminal extractor tool to withdraw each cable from the connector, which may then be discarded. Feed the harness through the mirror plinth before inserting the terminals into the replacement or original connector block in the following manner.

<i>Connector cavity</i>	<i>Cable colour</i>	<i>Function</i>
1	Not used	Not used
2	Brown	Up/down
3	Orange	Mirror common
4	Pink	Left/right
5	Red	Fold in
6	Blue	Fold out
7	Black	Mirror heater
8	Black	Mirror heater ground

8. Continue re-assembly in reverse order to removal.

BV.9 - DOOR SHELL, BEAM & HINGES

The door comprises an inner and outer composite moulding, bonded together around the periphery, and enclosing a hollow section, extruded alloy, door beam with internal siffening webs, to provide side intrusion protection. A fabricated steel hinge post is bonded to the inside of the door shell front face, and provides a 2-bolt mounting for the front end of the door beam. Similarly, another fabricated steel bracket is bonded to the inside of the door shell rear face, and provides a 2-bolt mounting for the rear end of the door beam. The components so far described, are available only as a jig-built, door shell assembly.

Each door uses two identical hinges, each comprising two steel forgings, one with a single eye for bolting



to the door shell, and one with a double eye for bolting to the chassis hinge post, the oversize holes providing sufficient positional tolerance for door shutline adjustments to be made. Synthetic bushes and a steel tube provide the maintenance free pivot mechanism, with the two hinge halves being mated by a pivot bolt to allow door removal without losing the alignment settings. The hinges also feature open limiting stops, although this function is subsumed to the check strap.

A check strap is fitted to limit door opening and also to provide a mid-point detent position for convenience in restricted space. The check strap unit is secured to the inside front face of the door shell with two screws, and uses spring loaded Nylon jaws to embrace a profiled steel link fixed by a single bolt to the chassis 'A' post.

### To remove/refit door assembly

The complete door assembly may be removed from the car by the following procedure:

1. Remove the door hinge post trim panel and unplug the door harness connector. Feed the connector through the hinge post aperture.
2. Release the check strap from the 'A' post.
3. To preserve the shutline settings, support the door, remove the pivot bolt from each of the two hinges, and lift the door off the hinge pivot tubes.
4. Refit in reverse order to removal. If shutline adjustment is required, slacken the bolts securing the hinges to the door and 'A' post, move the door as required, and re-tighten.

### Check strap

The check strap is secured from inside the door shell by two M6 screws. To remove the strap, remove the door trim panel and membrane, fully raise the window, and release the two screws securing the check strap assembly. Remove the single fixing securing the strap to the 'A' post, and withdraw the strap.

## BV.10 - DOOR WEATHERSTRIP SEALS

### Drop glass waist seal

The door drop glass uses flocked EPDM wipe seals on the inner and outer top edges of the door shell to minimise water ingress into the door. Each main length of seal is bonded to an aluminium 'U' section barbed carrier, which is pressed on to the appropriate door top flange. These two seals are linked around the back of the door shell glass slot, by an integrated moulded capping section secured to the door by two push button fixings. The seal should be removed from the door before attempting to remove the door glass or guide rails.

To remove the seal, lower the door glass fully. Press in the centre pin of the two button fixings to allow them to be withdrawn, and carefully pull the two seals from the door shell flanges.

### Door cheater seal

The extension to the top front of the door moulding, designed to provide increased support to the door glass, and also to mount the door mirror, is referred to as the door 'cheater' panel. A moulded rubber seal is fitted around the cheater and secured by Rokut rivets and adhesive strips.

### Door weatherstrip

Each door weatherstrip seal comprises several extruded rubber sections and a right angle corner moulding, all bonded together to form a single service unit. The top, front and rear sections of the seal incorporate a gripper channel which is pressed onto the body flange. The bottom section is bonded to the sill via a self adhesive strip pre-applied to the seal. Before fitting the seal, thoroughly clean the bonding area on the sill using Betaclean 3900 (A100B6008V).

Start fitting the seal from the top rear corner, and ensure that the whole length of the 'U' section is pressed fully on to the body flange. Remove the backing tape and position the lower section against the sill. Use a roller wheel to ensure full adhesion.

### Secondary door seal

In order to minimise wind noise transmitted into the cabin, a secondary seal is fitted along the cant rail and down the 'A' post. This self adhesive, hollow section rubber extrusion, should be contacted by the door glass in its fully raised position (see BV.11).



BV.11 - DOOR WINDOW, GUIDE RAILS & LIFT MECHANISM

**WARNING:** To ease door closure, and optimise the sealing of the frameless door glass against the weatherstrips, the control mechanism will automatically drop a fully closed window a small distance when the door is opened (preparatory to closing), and raise it again after the door is shut. This function may be triggered, with ignition on or off, by door latching signals. Whenever working on or near the window mechanism, disconnect the window motor to prevent injury from unexpected operation.

Each door uses a single, 4mm thick, green tinted, tempered glass, curved door window, with a frameless configuration, and an electrically operated lift mechanism. The glass is guided by a pair of curved steel 'L' section channels, to which it is constrained by two pairs of point contact Nylon guide blocks bonded to the front and rear edges of the glass. The lower end of each of the guide rails is adjustable in/out via a screw mechanism, to enable the correct weatherstrip seal loading to be achieved, whilst the glass upward travel is limited by an adjustable stop on the lift mechanism.

The lift mechanism uses a top hat section steel lift channel, curved to match the window guide rails, and attached to the door shell. An alloy carriage plate, clamped to the bottom of the glass, uses a plastic shoe to slide along one edge of the lift channel. A multistrand steel cable is attached to the carriage plate and is routed around a pulley at the top and bottom of the lift channel and then around a drum driven by an electric motor. The assembly thus described is secured at 3 points to the door shell.

A micro-switch mounted on the lift mechanism closes when the glass is fully raised, and triggers the window automatic drop function when the door is opened.

Viewed From Outboard

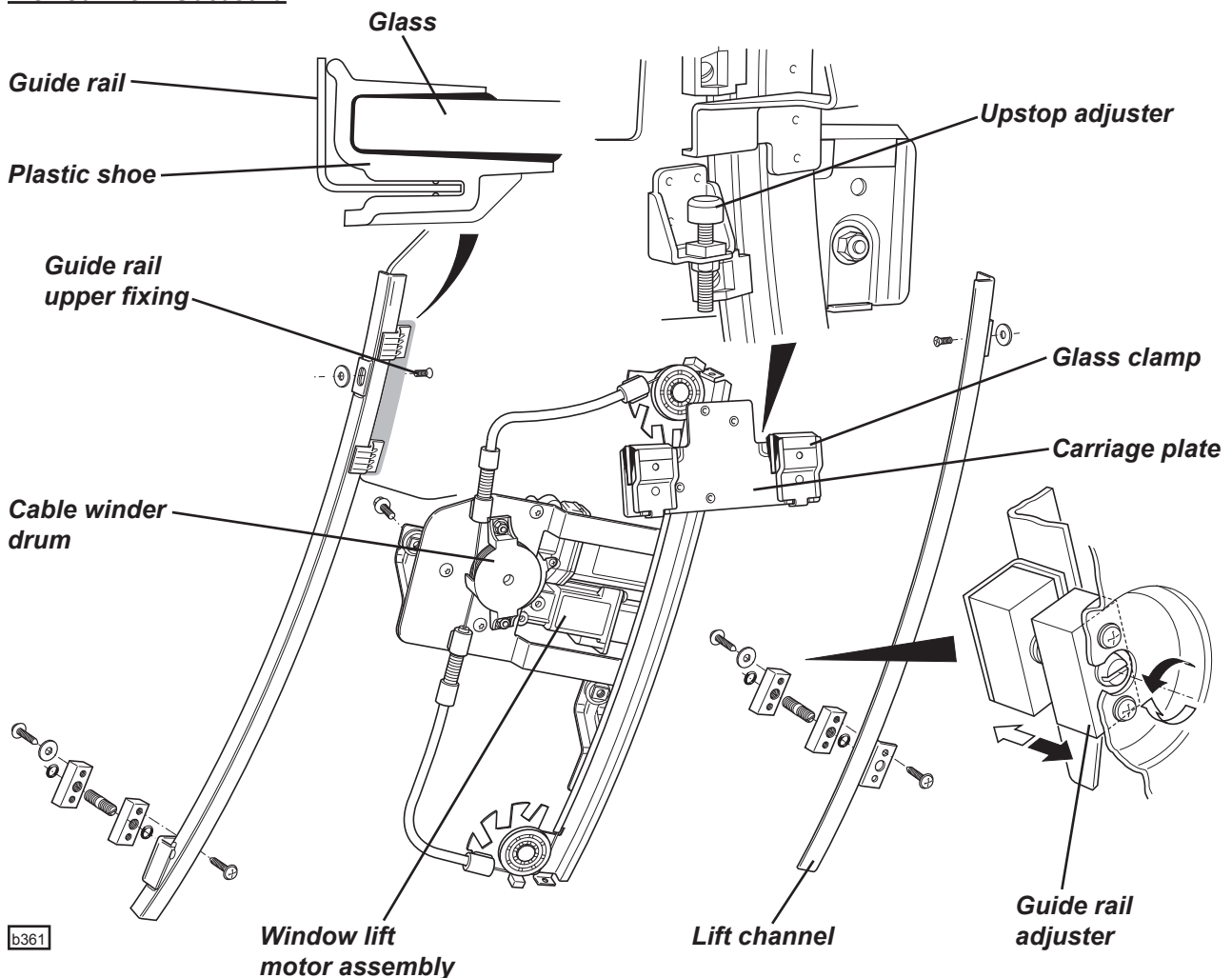



## Door glass adjustment

To provide optimum weather sealing, several adjustments are available to position the glass correctly, with sufficient weatherstrip seal loading.

*Glass top edge alignment:* When fully raised, the glass top edge needs to be aligned to the roof and cant rail seal. If adjustment is required, the door trim panel and membrane must first be removed for access (see sub-section VE.2). The glass is secured to the carriage plate by two rubber lined clamps; release the two clamp nuts, re-position the glass as necessary and re-tighten.

*Glass height adjustment:* An adjustable upstop buffer screw is mouted on the carriage plate, which abuts against a flange at the top of the window lift channel to limit upward travel of the glass. Complete but light contact between the fully raised glass and cant rail seal is required.

*Glass inward tilt:* The inward tilt of the glass may be adjusted by screw threaded anchorages for the bottom ends of the two guide rails. These are accessible with the trim panel fitted. Light contact with the weatherstrip seals is required.

## Door glass removal

1. Remove the door trim panel and membrane (see sub-section VE.2).
2. Remove the door glass waist seal (see sub-section BV.10).
3. Release the two clamps securing the glass to the lift channel, and slide the glass out of the door.
4. New door glasses are supplied with the slider blocks pre-fitted. If a slider block should become detached, the old adhesive should be cleaned off, the bonding surfaces cleaned with Betaclean 3900 (A100B6008V), and the following products used to rebond the slider block using the adhesive manufacturer's instructions:  
Permabond Initiator INI 5 A000Z0043F  
Permabond Flexon F246 B089B6125V

## Guide rail removal

1. Remove the door glass (see above).
2. Release the single screw securing the top of the rail to the bonded bracket or mirror mounting bracket, noting any shim washers fitted.
3. Release the 2 screws securing the bottom end of the rail to the adjuster screw block, and withdraw the rail from the door.

## Window lift mechanism

The lift mechanism is available only as a complete assembly and is secured to the door shell by three fixings. The mechanism may be removed whilst leaving the glass and guide channels in place, but access will be improved if the glass can be fully raised.

1. Release the two clamps securing the glass to the carriage plate.
2. Disconnect the harness from the lift motor and micro switch.
3. Release the three retaining screws and withdraw the lift mechanism from the door.
4. When re-fitting, adjust the glass height and alignment as detailed above.



BV.12 - DOOR LATCH MECHANISM

The door latch mechanism is fitted inside the rear face of the door, which is reinforced by a steel plate bonded to the composite door shell, and which is also used to secure the rear end of the door beam. The latch engages with a striker hoop which is secured to a bracket integral with the seat belt mounting frame. The external key lock (fitted only on the LH door) is connected to the latch mechanism by control rod, as are the door sill buttons, and exterior release handles. The interior release handle is connected via a control cable. The latch contains a microswitch to detect when the door is closed, and which is used to operate the courtesy lamp, alarm system, door glass drop functions, and others. The electrical locking actuator is mounted on a bracket integral with the latch mechanism with which it interacts via a rotary link.

A plastic security shield is fitted around the latch mechanism to inhibit illicit interference with the locking system.

Normal operation of the locking functions is performed electronically via the transmitter fob (see Section MR), but if necessary, the doors can be locked mechanically. The LH door can be locked by using the key in the exterior lock barrel. Both doors can also be locked individually by lifting the exterior release handle (with door open), pressing down the door sill button, and keeping the handle lifted, shutting the door. This action will also disable the interior release handle. Once locked in this way, the RH door can be unlocked only by using the transmitter fob or by raising the door sill button after opening the LH door via the mechanical key.

**WARNING:** The window control mechanism includes an automatic window drop and raise logic to aid door closing and weathersealing. This function may be triggered, with ignition on or off, by door latching signals. Whenever working on or near the window mechanism, disconnect the window motor to prevent injury from unintended operation.

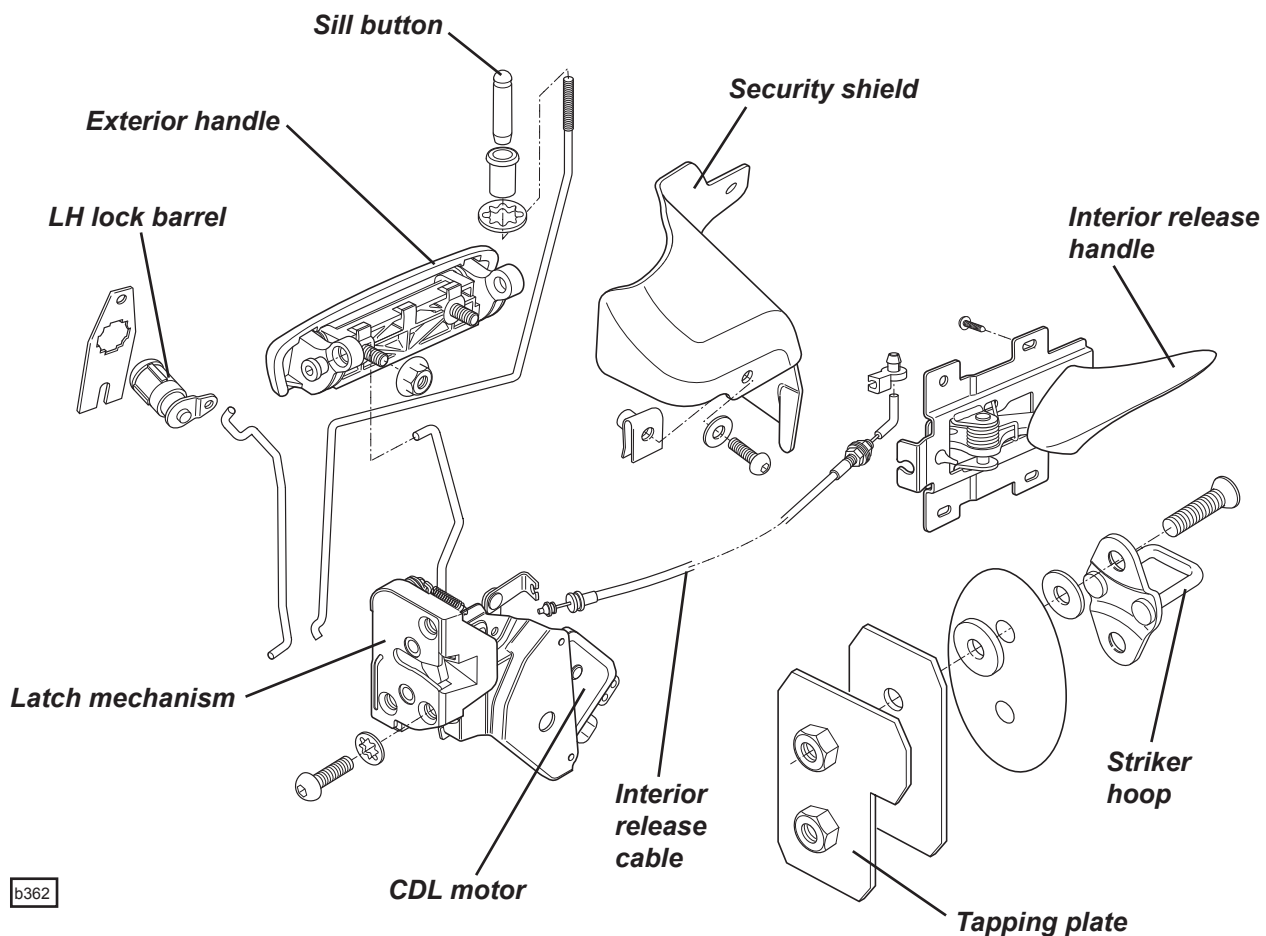

b362





## Exterior release handle

The exterior release handle is secured to the door shell by two studs. To remove the handle, remove the door trim panel and membrane (see section VE.2), fully raise the window, and unclip the control rod from the handle. Release the two retaining nuts, and withdraw the handle.

## LH door exterior lock

An exterior key lock is provided only on the LH door. To remove the lock assembly, remove the door trim panel and membrane (see section VE.2), fully raise the window, and unclip the control rod from the latch mechanism. Release the three nuts securing the lock mounting plate to the door, and withdraw the plate and lock assembly. A spring clip secures the lock to the mounting plate.

## Latch mechanism

To remove the latch mechanism:

1. Remove the door trim panel and membrane (see section VE.2).
2. Fully raise the window and unclip the exterior lock rod from the latch (LH door only).
3. Unclip the control rod from the exterior release handle.
4. Unclip the interior handle release cable from the latch.
5. Unplug the door harness from the latch actuator, and the microswitch.
6. Release the three screws from the door shut face securing the latch mechanism, and withdraw the unit together with the sill button control rod from the door.
7. On re-assembly, remember to fit the sill button control rod to the latch mechanism before installing the mechanism into the door.

## BV.13 - WINDSCREEN REMOVAL/REPLACEMENT

The Evora windscreen is constructed from two layers of glass, the inside component of which is green tinted, sandwiching a synthetic solar reflecting interlay, to form a 5mm thick laminate. A black ceramic obscuration band with graduated fade out, is applied to the inner surface periphery. The windscreen is bonded to the composite body frame using an elastomeric polyurethane adhesive, and contributes to the structural integrity of the body assembly. The screen uses rubber extrusions along the top and bottom edges for visual enhancement, and black finished alloy finishers over each 'A' pillar. Screen replacement will require new top and bottom filler strips, but the side finishers may be salvaged if carefully removed.

### *Parts required:*

- Windscreen.
  - Betaseal Kit A075B6158F.
  - Plinth, interior mirror mounting (supplied with new windscreen).
  - Plinth Adhesive Kit A116U0194F.
  - Top and bottom filler strips.
1. Pull the door weatherstrip off the windscreen frame flange along both 'A' pillars. Remove the 'A' pillar finisher fixing nuts; one at the lower end beneath the corner of the clamshell; three along the 'A' pillar shut face. Use a knife blade or similar between the glass and the finisher to gently ease the finisher away from the double sided tape fixing. Withdraw the finisher with the secondary door seal still attached and secure aside with tape.
  2. If a cutting wire is to be used to release the windscreen bonding, it may not be necessary to disturb the front clamshell. If a vibrating knife is to be used, it is likely that the rearmost fixings for the clamshell will need to be removed to allow tool access to the bottom corners of the screen.



- Slide the interior mirror stem from the windscreen plinth. Remove the sun visor retaining screws to allow the front of the head lining to drop. Pull each 'A' pillar trim panel out from its three captive 'fir tree' fasteners (a fourth fir tree button at its lower end is inaccessible), to protect from adhesive cutting tool damage.
- Remove the windscreen wiper arm and attach suction handles to the glass. Using a cutting wire or dedicated vibrating knife of suitable form, cut the adhesive bead around the entire periphery of the screen, taking precautions as necessary to prevent paint or body damage. Note that the top and bottom rubber finisher strips are likely to be cut through during this operation and will require replacement. With assistance, lift the glass from the car.
- Remove old adhesive from the windscreen frame sufficiently to leave a consistent and flat surface for the new bonding medium.
- Clean the whole of the windscreen periphery bonding surface, including the mirror plinth area with the wipe cleaner supplied in the Betaseal Kit, or with Betaclean 3900 (A100B6008V). Allow to dry.
- Prime the bonding surface of the new mirror plinth and the corresponding glass area with Dymax 500E activator A111B6187. Use Dymax 840 adhesive to bond the plinth to the glass following the supplier's directions. Position the plinth centrally and with the bottom, closed end, 7mm from the bottom edge of the obscuration patch.
- Prime the bonding area on the glass to a width of 25mm with Betaprime 5500 (green cap) A120B6041V, avoiding the VIN window. Allow the primer fully to dry.
- Fit the new self adhesive filler strip A132U0266F to the inside top edge of the glass, and the longer strip A132U0402F to the bottom edge.
- Prime and re-activate the prepared surface of the old adhesive on the windscreen frame with Betawipe 4000 (A082B6355V). If the windscreen frame surface is new or without adhesive, prime the frame with Betaprime 5404 (red cap) A082B6337V. Allow a minimum of 5 minutes for the primer to dry. If the screen is not fitted within 48 hours, the primer should be re-applied.
- Around the windscreen landing path, check the joints between windscreen frame and screen lower landing, and between the roof and body side 'A' pillars, for correct sealing and joint path integrity. If necessary, prepare these gullies for bonding as described above, and fill with adhesive sealant prior to windscreen fitment.

- Cut the nozzle of the adhesive cartridge to the dimensions shown to produce a triangular section bead. Holding the cartridge perpendicular to the glass, extrude a bead of Beta-seal 1701 adhesive (A082B6281F) around the screen using the inner edge of the top and bottom filler strips as a guide, and following the centre of the primer band along each side.

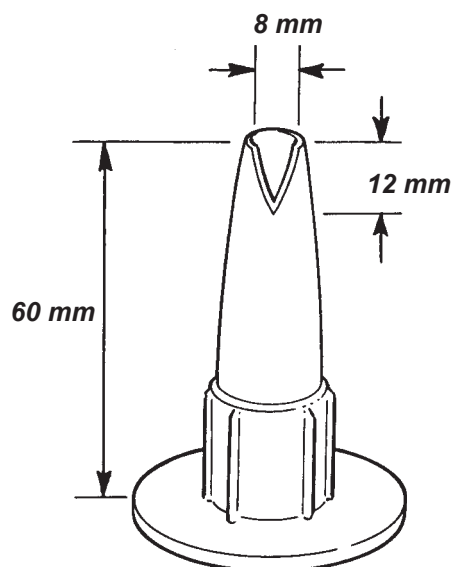

b264



13. Insert three 6mm spacer blocks A132U0346F into the inside edge of each 'A' pillar bead.
14. Apply suction handles to the glass, and with assistance, carefully fit the glass onto the frame, taking care to position it centrally (compare dimensions at each side between glass and body edges) and with the upper filler strip in uniform contact with the roof edge. Press down on the glass around the periphery to compress the joint onto the spacer blocks and then secure in position using duct tape or other methods to support the screen until the adhesive has cured. This will take around 4 hours, with a longer period required in dry atmospheric conditions.
15. Before curing, examine the whole length of the joint for integrity, and if necessary, extrude additional adhesive locally into the joint to ensure complete sealing. Use a spatula or similar tool if required to force the adhesive into the appropriate area. Use a spatula or whetted gloved finger to smooth out or remove any excess extruded material to leave a neat appearance. Alternatively, cut away after curing using a scalpel knife.
16. Check the fitted condition of the lower rubber finisher, and if necessary, adjust the height of the windscreen bottom gutter to align correctly with the screen bottom edge.
17. After adhesive cure, continue re-assembly in reverse order to disassembly, applying fresh double sided tape to the 'A' pillar finishers.

### Spillage of material

- a) Any spillage of Betaseal onto unprimed glass can be readily peeled off after it has cured.
- b) Any spillage onto the bdy can be removed with either Wipe Cleaner No.4, or white spirit.

### Shelf life

- a) Betaseal primer has a useful life of about 24 hrs. after exposure to the air, after which it starts to become spongy. If the material is spongy, DO NOT USE. Always use glass primer immediately on opening, and replace the lid after use.
- b) Betaseal has a shelf life of over 6 months at ambient temperature in the original unopened package.

### BV.14 - TAILGATE GLASS

The grey tinted, 5mm thick, tempered glass screen, incorporates an electrical heating element and is bonded to the composite tailgate panel using Betaseal flexible polyurethane adhesive. A black ceramic obscuration band with graduated fade out, is applied to the inner surface periphery.

### To Replace Tailgate Glass

Parts required:

- Tailgate Glass.
- Screen adhesive cutting equipment.
- Betaseal Kit A075B6158F.

1. Apply suction handles to the outside surface of the glass, and disconnect the two HRS cables from the inside.
2. Using a dedicated vibrating cutting knife of suitable form, cut the adhesive bead around the entire periphery of the screen, taking precautions as necessary to prevent damage to paintwork or body flange.
3. After cutting out the glass, remove old adhesive from the tailgate aperture sufficiently to leave a consistent and flat surface for the new bonding medium.
4. Clean the whole of the bonding surface on the new glass, and the bonding surface on the tailgate aperture, with the wipe cleaner supplied in the Betaseal Kit (or Betaclean 3900 A100B6008V).
5. Prime the bonding area on the glass to a width of 25mm with the primer in the kit, or with Betaprime 5500



(green cap) A120B6041V.

6. Prime and re-activate the prepared surface of the old adhesive on the tailgate with Betawipe 4000 (A082B6355V). If the tailgate bonding surface is new or without adhesive, prime the tailgate with Betaprime 5404 (red cap) A082B6337V.
7. Allow a minimum of 5 minutes for the primer to dry. If the glass is not fitted within 48 hours, the primer should be re-applied.
8. Cut the nozzle of the Betaseal cartridge as shown in sub-section BV.13, and holding the cartridge vertically, extrude a bead of adhesive around the glass periphery using a finger against the glass edge as a guide. Manipulate the two ends of the bead together for a consistent joint.
9. Cut six 4mm spacer blocks from the material supplied in the Betaseal kit (or use 6 off A124U0069F), and position in the inside edge of the adhesive bead, two along the top bead, two along the bottom, and one centrally in each side bead. These spacers are used to control the fitted height of the glass.
10. Using suction handles, carefully lower the glass onto the tailgate, and position centrally in its aperture. Press around the periphery of the glass to compress the adhesive until contact with the spacer blocks is felt. Carefully examine the integrity of the whole length of the joint, if necessary using a spatula to force extra adhesive into any depleted areas. Wipe off any excess adhesive extruded from the joint, or alternatively, allow the adhesive fully to cure and cut away any excess using a scalpel blade.
11. Position the tailgate horizontally and use duct tape to hold the glass in position until the Betaseal is fully cured. This will take approximately 4 hours dependent on atmospheric conditions, with a longer period required in dry atmospheres. Reconnect the HRS cables.

Refer to sub-section BV.13 for spillage of material and shelf life advice.

### BV.15 - CABIN REAR WINDOW

The cabin rear window is a double glazed unit to enhance insulation from engine bay heat and noise, and consists of two clear, 4mm thick, tempered glass panes, bonded around the periphery to a 6mm thick synthetic spacer, with the sealed space filled with argon gas. A black ceramic obscuration band with graduated fade out, is applied to the forward face of each glass pane. The window is bonded to the cabin rear bulkhead using Betaseal flexible polyurethane adhesive.

### BV.16 - REAR QUARTER LIGHT WINDOW

Each rear quarter light window comprises a green tinted, 4mm thick, tempered glass pane, bonded to the body side panel with Betaseal flexible polyurethane adhesive. A black ceramic obscuration band with graduated fade out, is applied to the inside periphery of the glass, and an extruded rubber finisher is bonded along the top edge. It is unlikely that the top finisher will be re-usable after glass removal.

#### **To Replace Rear Quarter Light Glass**

1. Remove the rear clamshell (see sub-section BV.6).
2. Pull off the top rear section of the door weatherstrip seal, and peel off the rubber finisher moulding from the front edge of the quarter light glass.
3. Remove the rear quarter trim panel and 'B' post upper trim (see section VE.11).
4. From inside the car, and using a dedicated vibrating cutting knife of suitable form, cut the adhesive bead around the periphery of the window, taking care to avoid damage to paintwork or body flange.



5. After cutting out the glass, remove old adhesive from body flange sufficiently to leave a consistent and flat surface for the new bonding medium.
6. Clean the whole of the bonding surface on the new glass, and the bonding surface on the tailgate aperture, with the wipe cleaner supplied in the Betaseal Kit (or Betaclean 3900 A100B6008V).
7. Peel off the backing tape, and apply a new finisher strip to the inside top edge of the glass, aligning the cut back feature on the extrusion with the front edge of the glass.
8. Prime the bonding area on the glass to a width of 25mm with the primer in the kit, or with Betaprime 5500 (green cap) A120B6041V.
9. Prime and re-activate the prepared surface of the old adhesive on the body with Betawipe 4000 (A082B6355V). If the body side panel is new or without adhesive, prime the flange with Betaprime 5404 (red cap) A082B6337V.
10. Allow a minimum of 5 minutes for the primer to dry. If the glass is not fitted within 48 hours, the primer should be re-applied.
11. Cut the nozzle of the Betaseal cartridge as shown in sub-section BV.13, and holding the cartridge vertically, extrude a bead of adhesive around the glass periphery. Manipulate the two ends of the bead together to form an unbroken ring.
12. As shown in the illustration, insert into the top run of adhesive two 5mm spacer blocks A124U0069F, and into the bottom run, two 4mm spacers A075U0588F.
13. Using a suction cup, carefully position the glass onto its aperture, with the finisher strip consistently abutting the roof panel, and the front edge aligned with the door shut rebate.  
Press around the periphery of the glass to compress the adhesive until contact with the spacer blocks is felt. Carefully examine the integrity of the whole length of the joint, if necessary using a spatula to force extra adhesive into any depleted areas. Wipe off any excess adhesive extruded from the joint, or alternatively, allow the adhesive fully to cure and cut away any excess using a scalpel blade. Use duct tape to hold the glass in position until the Betaseal is fully cured. This will take approximately 4 hours dependent on atmospheric conditions, with a longer period required in dry atmospheres.
14. Refit front edge finisher, interior trim panels and rear clamshell.

Refer to sub-section BV.13 for spillage of material and shelf life advice.



FRONT SUSPENSION

SECTION CK

	<u>Sub-Section</u>	<u>Page</u>
General Description	CK.1	3
Geometry & Adjustments	CK.2	3
Wishbone Pivot Bushes & Swivel Joints	CK.3	6
Anti-Roll Bar	CK.4	7
Suspension Disassembly/Assembly	CK.5	8
Front Wheel Bearings	CK.6	10



General Arrangement

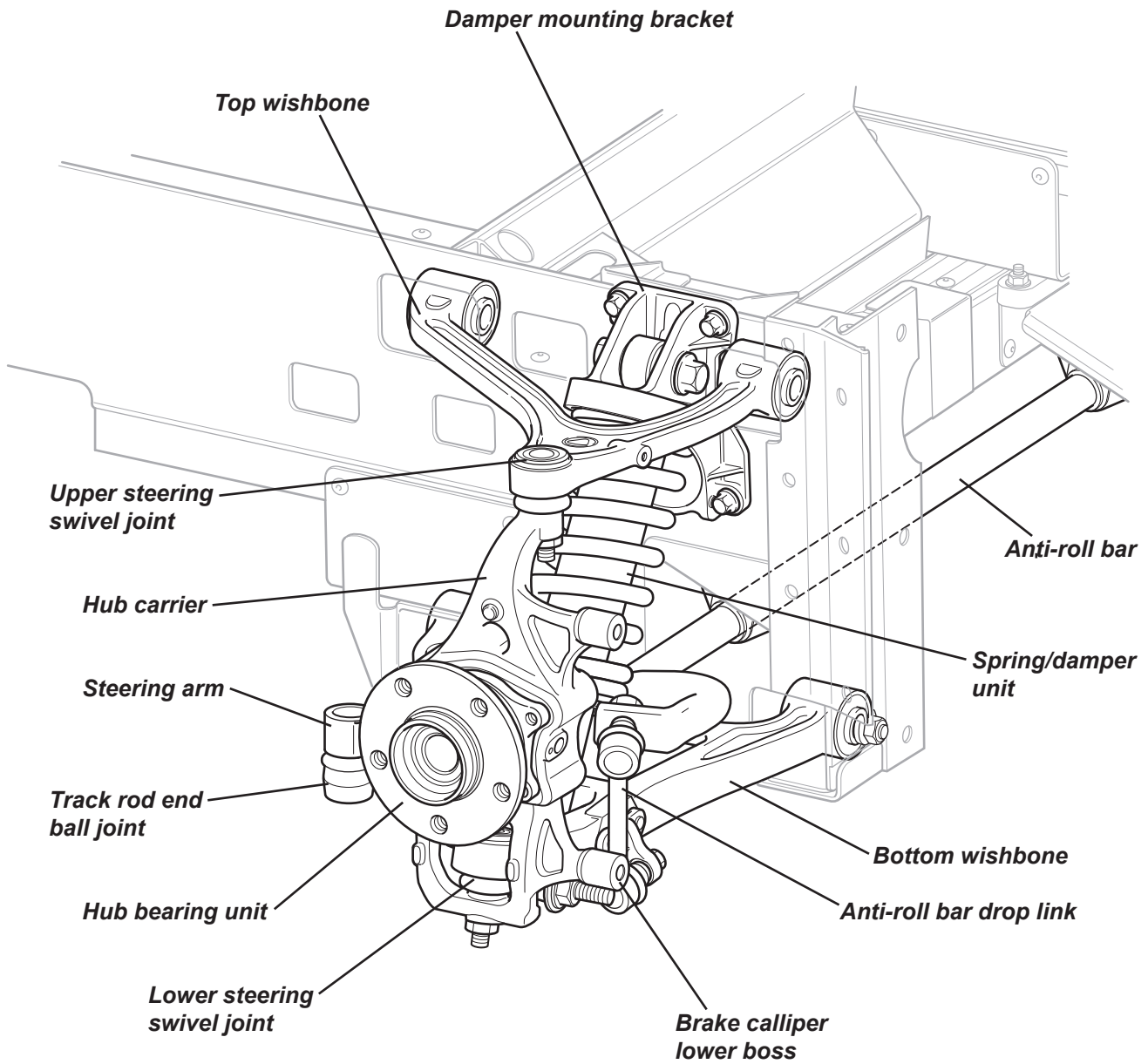



CK.1 - GENERAL DESCRIPTION

The independent front suspension comprises, on each side of the car, upper and lower forged aluminium wishbones, a concentric coil spring/telescopic damper unit, and a tubular anti-roll bar. A forged steel hub carrier, provides a mounting for the hub bearing unit to which the 5-bolt road wheel and brake disc are attached, and also features an integral steering arm and mounting bosses for the brake caliper.

The primary, vehicle weight bearing, lower wishbone, is braced by two integral struts and features an integrated steering swivel lower ball joint, a pair of press fit bonded rubber pivot bushes, and attachment points for a fabricated steel bracket carrying the damper lower end, and a forged steel bracket for the anti-roll bar drop link. The upper wishbone is a simple open 'A' frame, into the apex of which the upper steering swivel ball joint is integrated.

The inboard ends of both wishbones use replaceable bonded rubber pivot bushes for maintenance free articulation, with a compliance profile tuned to provide the vehicle with accurate and responsive dynamic characteristics. Eccentric cams incorporated at the front and rear pivot points for the lower wishbone, provide for the adjustment of both camber and castor.

The bottom of the Bilstein monotube telescopic damper fixes to the lower wishbone via a folded steel cradle bolted to both arms of the wishbone, with the damper top end fixing to the subframe via a substantial alloy casting bolted to the subframe longeron. The damper uses a bonded rubber bush in the top eye for noise suppression, and a through bolted spherical steel joint in the lower eye for optimum dynamic response, and is orientated with the damper rod uppermost. The dual rate concentric coil spring abuts against a lower seat on the damper body, and a rubber cushioned upper seat incorporated in the damper top mounting bracket, thus relieving the damper top bush from vehicle weight to the benefit of noise and ride refinement. The dual rate coil spring is mounted with the close coiled end lowermost.

A 28mm o.d. tubular steel anti-roll bar is mounted in rubber bushes to the underside of the subframe and projects through the lower wishbone before connecting to the wishbone rear leg via a short ball jointed drop link and a forged steel bracket.

The hub bearing unit, which is common to all four wheels, is fixed to the hub carrier by 4 bolts, and incorporates a double row ball bearing with the inner race of the outboard bearing formed directly in the hub forging, and the inner race of the inboard bearing retained by a swaging operation on the hub flange. Inboard and outboard grease seals are included in the assembly, with a vehicle speed sensor ring integrated into the inboard seal, whose 48 pole signal is picked up by a sensor mounted in the rear of the hub carrier. This data is used for the anti-lock brake, vehicle stability, engine management and speedometer functions.

CK.2 - GEOMETRY & ADJUSTMENTS

Provision is made for the adjustment of wheel alignment, camber and castor. Under normal service conditions, no periodic scheduled check of the geometry is necessary, although a front wheel alignment check is recommended when the front tyres are replaced. A full geometry check is required only after front suspension component replacement, or if excessive tyre wear is evident, or if steering difficulties are manifest. Before any measurements or adjustments are made it is essential first to set the vehicle to its 'mid-laden' ride height, approximating to driver and passenger and a full tank of fuel. This will require the vehicle to be ballasted, or pulled down on a ramp:

Type		Independent. Upper and lower wishbone; co-axial coil spring/telescopic damper; anti-roll bar.
Mid-laden ride height (2x75 kg occupants + full fuel tank) - set car to this height before measuring geometry:		
	- front	125 mm below front end of chassis siderail
	- rear	147 mm below rear end of chassis siderail
Castor	- optimum	+ 5.2°
	- tolerance range	+ 5.0° to + 5.5°; max. side/side 0.3°
Camber	- optimum	- 0.3°
	- tolerance range	- 0.5° to - 0.2°; max. side/side 0.2°
Alignment	- optimum	Zero
	- tolerance range	0.5 mm toe-out, to 0.5mm toe-in overall
Steering axis inclination		9.4° nominal





**Alignment**

Wheel alignment refers to the parallelism of the wheels when viewed from above and is crucial to vehicle stability, handling and tyre wear.

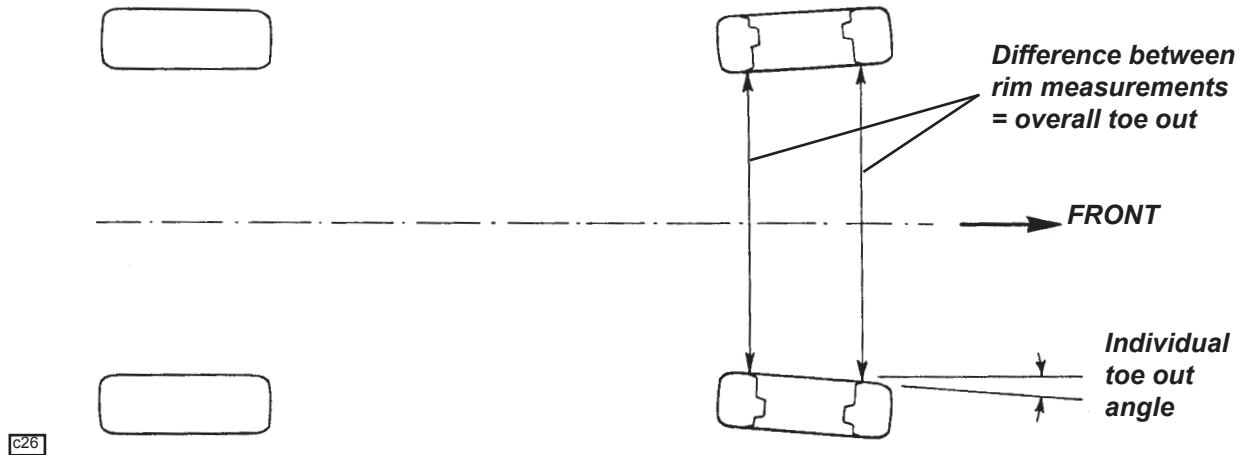

c26

Alignment is measured either by the angle a wheel makes with the vehicle centre line, or the difference in dimension between the wheel rim to wheel rim measurement at the front and rear of the wheel at hub centre height. The wheels are said to 'toe-in' when the wheel paths converge ahead of the vehicle, and 'toe-out' when they diverge. Wheel alignment is designed to vary with both steering angle (Ackerman) and suspension travel (bump steer) and should be measured only 'straight ahead' at the specified ride height.

Front wheel alignment is adjusted by screwing the rack tie rods into or out of the track rods. In order to preserve the required bump steer characteristic and steering symmetry, the effective length of each track rod must remain equal - adjust each tie rod by a similar amount.

**To be revised**

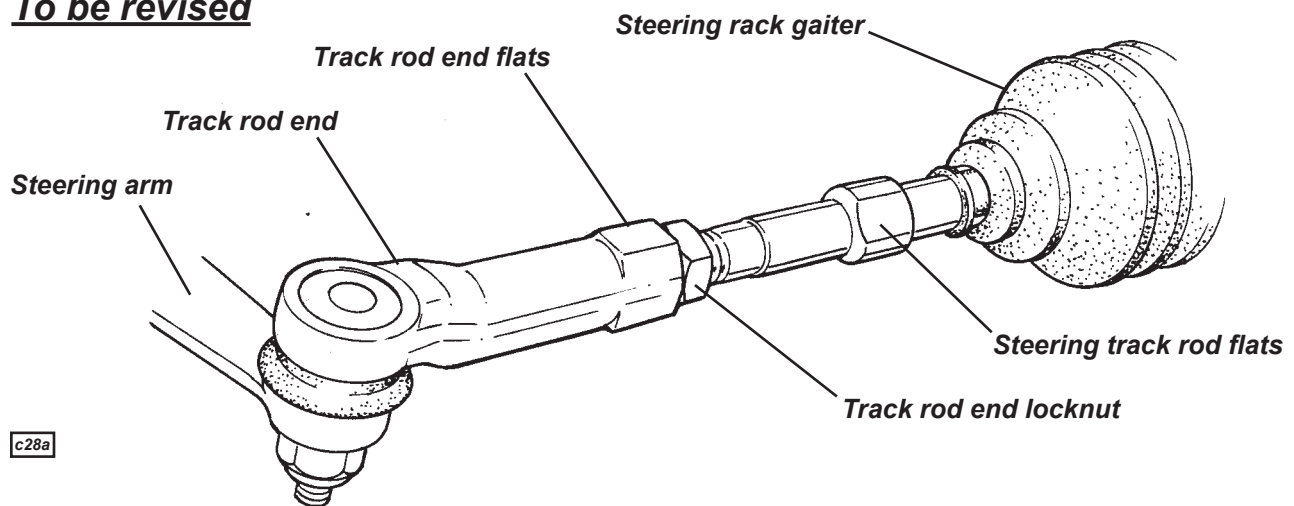

c28a

- Hold the track rod using the flats provided, and slacken the locknut. Repeat for the opposite side.
- Turn each tie rod a similar amount. As a guide, turning both tie rods by one quarter of a turn will alter overall toe-out by approx. 2.0 mm.
- When adjustment is correct, hold each track rod and tighten the locknuts to 80 - 82 Nm (58 - 60 lbf.ft).

When slackening or tightening the track rod locknuts, it is important that the torque reaction is resisted using the track rod flats, and that the outer ball joint is not allowed to be stressed.



**Camber Adjustment**

Camber is the angle from vertical of the wheel when viewed from the front, and is said to be negative when the wheel leans inwards at the top (positive when leaning outwards). The primary purpose of camber is to achieve the maximum efficiency of the tyre under cornering loads and body roll, with the specification closely allied to a particular wheel/tyre combination. The camber angle changes with suspension travel, becoming more negative on bump, and should be measured only at the specified ride height. Incorrect camber can result in handling deficiencies and excessive tyre wear.

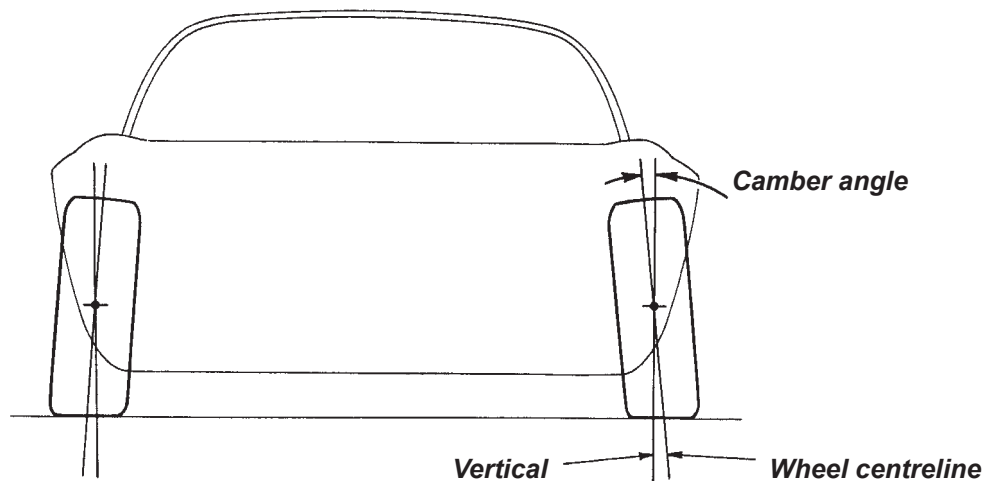

c29

Eccentric cams at the inboard pivots of the lower wishbone provide a means of camber adjustment. The front pivot bolt is inserted from the rear, and the rear pivot bolt from the front, with each bolt head featuring an integral eccentric cam. A corresponding eccentric camplate is clamped beneath the nut, and is keyed to the bolt via a tongue and groove feature to ensure alignment between the two cams. Each cam is constrained by vertical guides integral with the subframe structure, whereas the pivot bolt hole in the subframe is slotted horizontally. Thus by turning the bolt (and eccentric cams) the wishbone pivot point may be moved inboard or outboard.

When adjusting camber, the front and rear pivot bolts should be moved by a similar horizontal distance to minimise the effect on castor (see below) but be aware that the horizontal movement produced by turning the cambolts accords with simple harmonic motion, and is not linear. After adjustment, ensure that the nuts are tightened to 86 Nm (only at ride height).

**Cambolt Effects**

From a midpoint position (i.e. centres of bolt and eccentric on common vertical axis, stamped arrow pointing vertically upwards or downwards);

- Foreward cambolt;           90° cambolt rotation moves pivot horizontally by 5mm, and
  - changes camber angle by 0.25°
  - changes castor angle by 1°
- Rearward cambolt;       90° cambolt rotation moves pivot horizontally by 5mm, and
  - changes camber angle by 0.7°
  - changes castor angle by 1°

**Note:**

- Forward cambolt;           Moving pivot axis INboard;
  - reduces negative camber
  - increases castor
- Rearward cambolt;       Moving pivot axis INboard;
  - reduces negative camber
  - reduces castor
- Total adjustment range
  - camber    4°
  - castor     0.8°



**Cambolt illustration**

**Castor Adjustment**

Castor is the angle from vertical of the steering axis of the wheel when viewed from the side. Its primary purpose is to provide a natural straight running tendency of the steered wheels with forward vehicle motion. Castor angles have a complex interaction with other steering geometries and if unbalanced or outside of specification, can result in various stability and handling deficiencies.

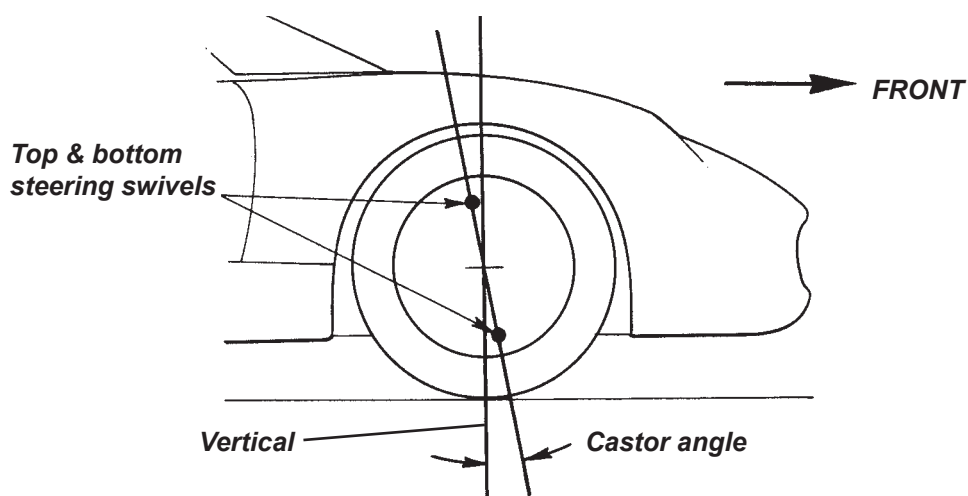

c27

The eccentric cams fitted at both front and rear inboard pivots of the lower wishbone (see 'Camber Adjustment' above) are also used to adjust castor. By moving the rear pivot axis outwards, and the front pivot inwards, the lower swivel joint is moved forwards to result in an increase in castor angle. To reduce the effect of this adjustment on camber angle, the front pivot point will need to be moved laterally about three times the distance, and in the opposite direction, to the rear pivot point movement.

After adjustment, ensure that the nuts are tightened to 86 Nm (only at ride height).

**CK.3 - WISHBONE PIVOT BUSHES & SWIVEL JOINTS**

**Pivot Bushes**

The upper and lower wishbone pivot bushes are bonded rubber type with a plastic flanged outer sleeve, an alloy inner sleeve, and an aluminium interleaf sleeve within the rubber bush to control the flexing characteristic. The rubber material specification has been selected to optimise the handling/refinement balance. The flanged end of the bush incorporates a snubbing feature to limit the axial distortion of the bush, with each bush arranged to resist braking forces transmitted through the suspension; Both top wishbone bushes are inserted from the front, and both bottom wishbone bushes from the rear. A chamfer is provided in the wishbone bore for this purpose.

The bushes may be pressed out of the wishbone eyes, and new bushes fitted using suitable press tool dollies. Smear the outer surface of the new bush with IPC 'P-80' rubber lubricant emulsion (A082C6042V) to ease fitment, and assemble in the direction detailed above.



**To be revised**

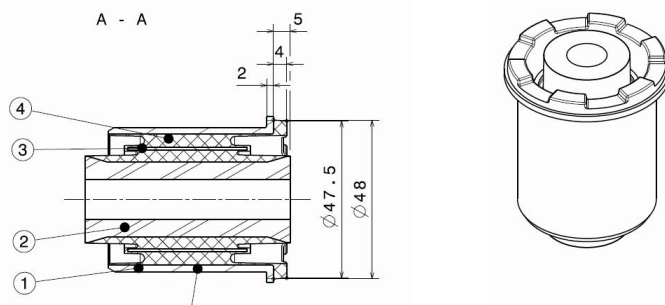

**Steering Swivel Joints**

The steering swivel joint housed in the outboard end of both the top and bottom wishbones, uses a steel ball pin located in a synthetic spherical bearing cup pressed into the wishbone and retained by a swaging operation. The joint requires no maintenance other than a visual inspection of the dust gaiter, and is replaceable only as an integral part of the wishbone assembly.

**Damper Pivots**

The lower eye of the damper is fitted with a zero compliance, through bolted, spherical joint which may be replaced using suitable press tools. The upper eye houses a bonded rubber bush, with a steel outer sleeve and an alloy inner sleeve. The bush may be replaced using suitable press tools.

**CK.4 - ANTI-ROLL BAR**

The tubular steel anti-roll bar is mounted beneath the front subframe in rubber bushes retained by extruded alloy clamps. One clamp secures the bar at each side to a bolt fixed, alloy extrusion, bridging the chassis drop towers for the lower wishbone front and rear pivots. Each end of the bar loops upwards through the lower wishbone and uses a short ball jointed drop link and forged steel bracket to connect to the rear leg of the lower wishbone. At each side, a washer crimped to the bar, bears against the inboard end of the chassis mounting bush to provide lateral location of the bar.

The drop link ball joints require no maintenance, and are replaceable only as part of the drop link assembly. The chassis mounted bushes are lubricated with rubber grease on assembly, but require no routine maintenance.

***ARB illustration***



## CK.5 - SUSPENSION DISASSEMBLY/ASSEMBLY

The suspension may be disassembled without the use of any special tools other than spring compressor clamps if the spring and damper are to be separated. With the car on a wheel free lift and with the front wheels removed:

1. Remove the wheelarch liner(s) as appropriate.

### **Hub Unit**

2. Remove the two bolts securing the brake calliper to the hub carrier, release the flexible hose from the top wishbone, and support the calliper aside without straining the brake hose. Release the single countersunk screw, and remove the brake disc.
3. Release the harness connector from the wheel speed sensor, release the harness from any suspension components, and secure the harness aside. Release the single screw securing the wheel speed sensor, and withdraw the sensor from the hub carrier.
4. Release the four hex. head securing bolts and withdraw the hub unit from the hub carrier. Note that this unit is common to all four wheels.

### **Hub Carrier**

5. Remove the nut securing the track rod ball joint into the steering arm, and use a ball joint splitter to separate the joint from the arm.
6. Remove the nut securing the top swivel joint to the hub carrier, and use a ball joint splitter to separate the joint.
7. Remove the nut securing the lower swivel joint to the hub carrier, and use a ball joint splitter to separate the ball pin from the carrier. Lift the carrier and hub unit from the car.

### **Damper and Spring**

8. If the damper and spring are to be separated, it is recommended to remove the complete assembly of spring/damper/top mounting bracket from the car in order that spring compression may be carried out in the safest manner.  
Remove the 4 bolts securing the top mounting bracket to the subframe, and the single bolt securing the lower end of the damper to the bottom wishbone bracket. Withdraw the assembly to a workbench.
9. Using spring compressor clamps and taking all suitable safety precautions, unload the spring seats and remove the bolt securing the top end of the damper to the mounting bracket.
10. Separate the spring, damper and top bracket, noting the spring top seat cushion, and unload the spring clamps.

### **Upper Wishbone**

11. Release the 'P' clip securing the brake hose to the wishbone, and the front and rear pivot bolts, and withdraw the wishbone from the subframe. The captive nuts for the pivot bolts are retained in channels in the chassis extrusions, replacement of the nutplate for the rear pivot requiring removal of the crash structure joining plate.  
Note that the steering swivel ball joint is retained in the wishbone by a swaging operation, and is serviced only as part of the upper wishbone assembly. For pivot bush replacement, see CK.3.

### **Lower Wishbone**

12. To aid re-assembly, match mark the eccentric cam adjuster positions at both pivot points for the lower wishbone. Release the anti-roll bar drop link from the wishbone, noting that a 5mm hexagonal socket is provided in the end of the ball pin stud to aid this process. Remove both pivot bolts and eccentric cam adjusters, and withdraw the wishbone.  
Note that the steering swivel ball joint is retained in the wishbone by a swaging operation, and is serviced only as part of the lower wishbone assembly. For pivot bush replacement, see CK.3.



- 13. If necessary, release the four bolts and remove the damper lower fixing bracket from the lower wishbone, and the remaining bolt securing the anti-roll bar drop link bracket.

**Anti-Roll Bar**

- 14. At least one of the lower wishbones must be removed before the ARB may be withdrawn. Release the anti-roll bar drop links from the ARB noting that the link assembly is symmetrical end to end. Note that the drop link ball pin self locking nuts should be discarded and renewed for re-assembly. Release the two bolts securing each of the two ARB pivot clamps to the chassis brackets and withdraw the anti-roll bar.

**Reassembly**

Re-assemble the suspension in reverse order to disassembly with the following notes:

- If the car suffers a suspension impact sufficient to damage a wheel rim, careful attention should be paid to all related suspension components, and replacement parts fitted in any cases of doubt.
- Smear the shank of each pivot bolt with PBC grease to inhibit corrosion and facilitate subsequent servicing, but do not allow grease contamination of the threads.
- Where bolts are threaded into captive nuts with no secondary locking mechanism, apply a suitable thread-locking compound. If separate self-locking nuts are used, assess the locking torque and renew the nuts in any case of doubt. The ARB drop link ball pin self locking nuts should always be renewed.
- Take care to match mark and refit the eccentric cam adjusters on the lower wishbone pivots in their original settings to facilitate subsequent geometry checking and adjustment.
- Lubricate the rubber type anti-roll bar mountings with rubber grease on assembly.
- Refit the plastic bung into the steering arm counterbore to prevent corrosion of the ball joint fixing.
- The damper body is provided with three location grooves for the circlip retaining the spring lower seat. Use the middle position for standard ride height setting. Use spring compressor clamps to assemble the spring/damper/top mounting bracket (spring close coils lowermost), before fitting the complete assembly to the car. Do not omit the spring top seat cushion.
- Pump the brake pedal to reposition the pads before driving the car.

The Service Schedule specifies that the security of the front and rear suspension is checked at each service. For cars used on race tracks, or in similar conditions, suspension components and torque checks should be carried out between sessions. This operation requires that all the principal suspension pivot bolts are torque checked, noting the following points:

Where a bolt is tapped into a housing or weldnut, and relies on a thread locking compound for security, it is important to appreciate that if the bolt is disturbed, the locking compound must be re-applied. The following procedure should be adopted for all such fixings:

- Check the torque of the fixing.
- If the specified torque is attained without the fixing being disturbed (moving), take no further action.
- If the bolt moves, the locking action of the thread adhesive will have been compromised. Remove the bolt completely, clean off all old adhesive using a wire brush and acetone, and apply new adhesive as specified.
- Refit the bolt and tighten to the specified torque.
- If for any reason a bolt is found to have become loose, and the car has been operated for any period in this condition, the bolt should be renewed as a standard precaution and related components carefully inspected for hole ovality, undue stress or wear.

<u>Torque Settings:</u>	<u>Nm</u>	
Upper and lower wishbone pivot bolts	86	
Upper and lower swivel joints to hub carrier	86	
Track rod end to steering arm	45	
Damper to lower wishbone bracket	135	
Damper to top anchor bracket	86	
Damper bracket to lower wishbone	45	
Spring/damper upper anchor bracket to chassis	45	
Hub bearing unit to hub carrier	70	+ Permabond A130
Brake calliper to hub carrier	86	+ Permabond A130
Anti-roll bar alloy mounting clamps to chassis	45	



Anti-roll bar drop links	38
Wheel bolts	105
Speed sensor to hub carrier	5
Brake disc retaining screw	10

## CK.6 - FRONT WHEEL BEARINGS

The hub bearing unit, which is common to all four wheels, is fixed to the hub carrier by 4 hex. head bolts, and incorporates a double row ball bearing with the inner race of the outboard bearing formed directly in the hub forging, and the inner race of the inboard bearing retained by a swaging operation on the hub flange. Inboard and outboard grease seals are included in the assembly, with a vehicle speed sensor ring integrated into the inboard seal, whose signal is picked up by a sensor mounted in the rear of the hub carrier.

If there is found to be any discernible free play in the hub bearing, or any roughness or tight spots can be felt, or any untoward noise heard, or any signs of lubricant expulsion are evident, the hub assembly should be replaced - there is no provision for adjustment or replacement of individual bearings.

### To Replace Hub Bearing Assembly

1. With the wheel removed, release the two fixing bolts, and remove the brake calliper from the hub carrier. Support clear of the brake disc without straining the flexible hose. Release the single countersunk screw and withdraw the brake disc from the hub.
2. Release the four bolts securing the hub bearing unit to the hub carrier.
3. Fit the new hub bearing unit to the hub carrier, apply PermaBond A130 (A912E7033) to the threads of the four bolts, and torque tighten to 70 Nm.
4. Refit the brake disc and calliper, using PermaBond A130 (A912E7033) on the threads of the calliper fixing bolts and torque tighten to 86 Nm. Pump the brake pedal to re-position the pads before driving the car.

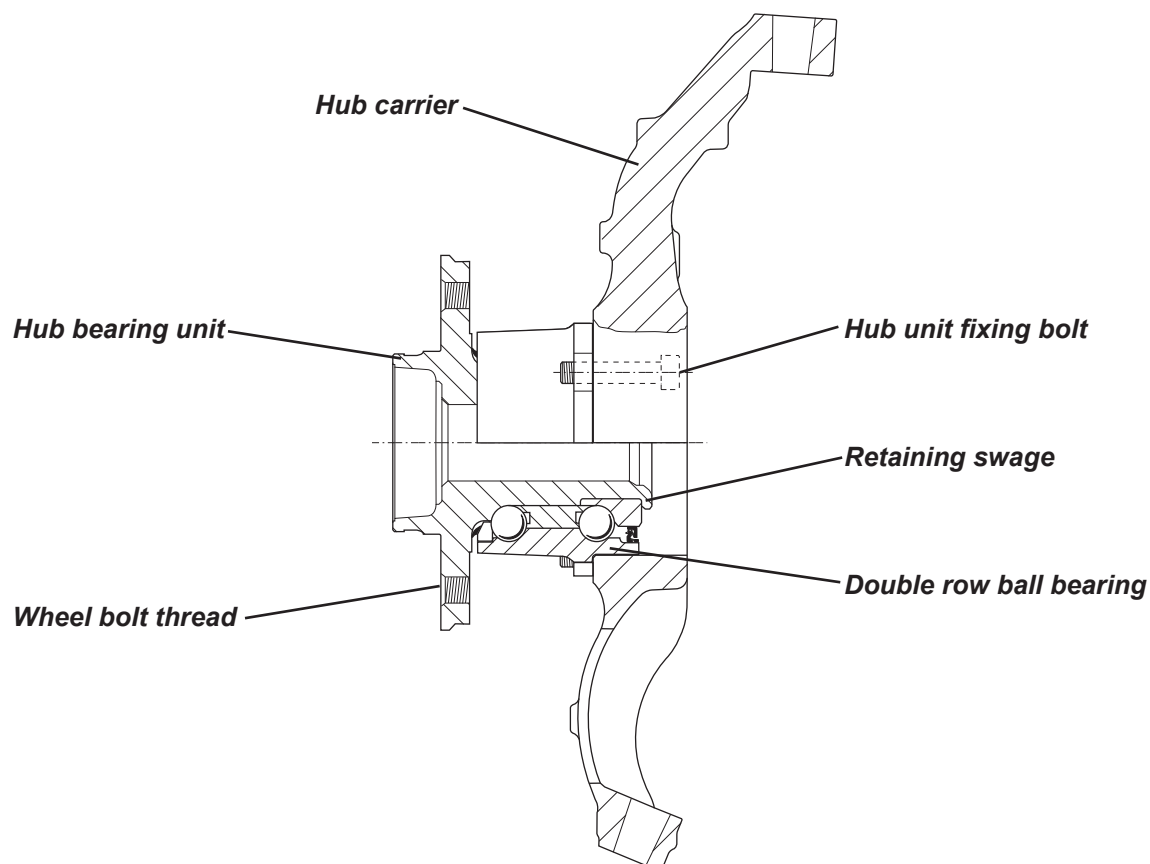

c50



**REAR SUSPENSION**

**SECTION DJ**

	<u>Sub-Section</u>	<u>Page</u>
General Description	DJ.1	3
Geometry & Adjustments	DJ.2	3
Wishbone Pivot Bushes & Spherical Joints	DJ.3	6
Anti-Roll Bar	DJ.4	6
Suspension Disassembly/Assembly	DJ.5	7
Rear Wheel Bearings	DJ.6	9





**Rear Suspension Layout**

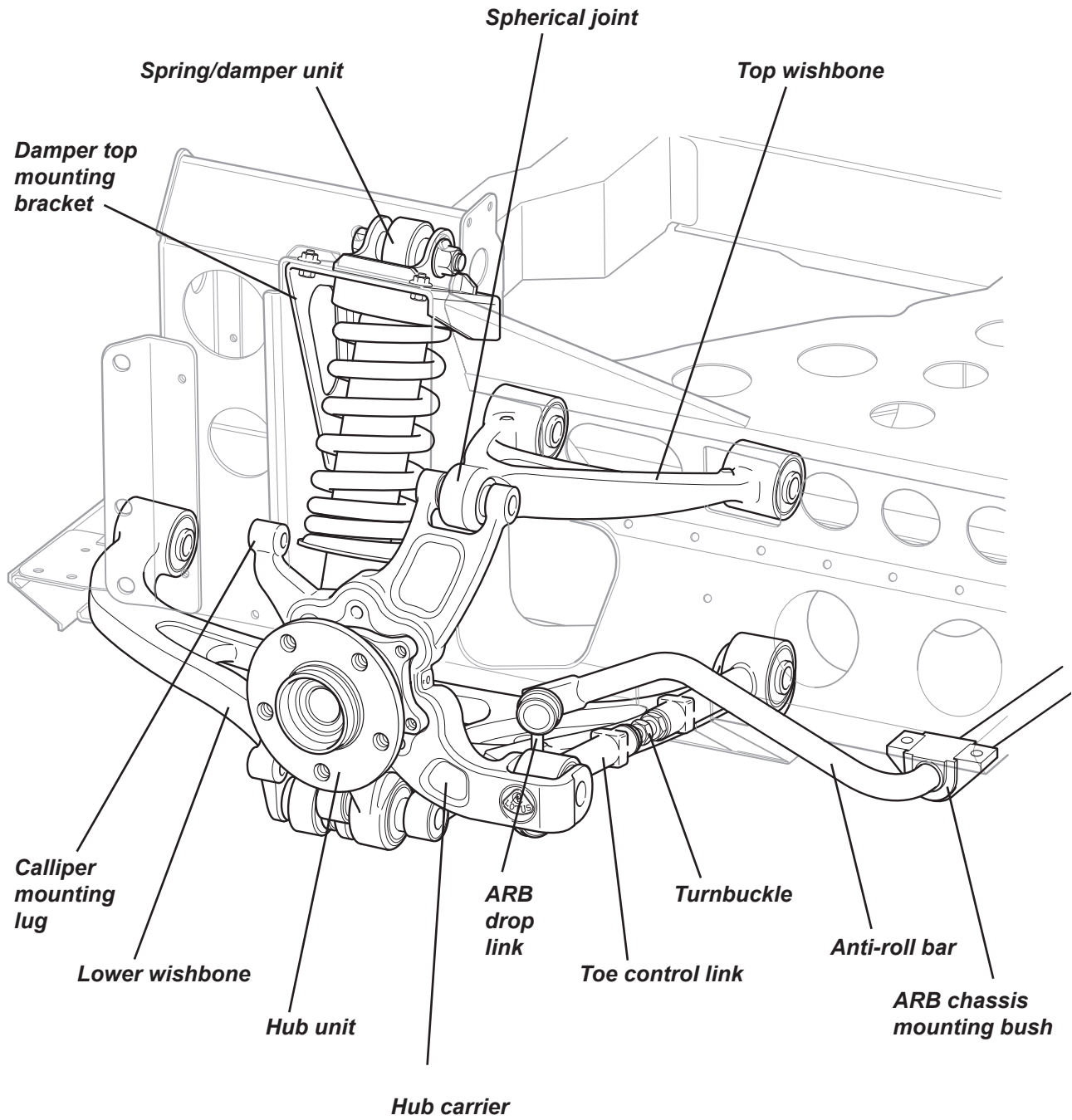



DJ.1 - GENERAL DESCRIPTION

The independent rear suspension comprises, on each side of the car, upper and lower forged aluminium wishbones, a forged steel toe control link, a concentric coil spring/telescopic damper unit, and a tubular steel anti-roll bar, all being attached to the galvanised steel rear subframe. A forged steel hub carrier, provides a mounting for the hub bearing unit to which the 5-bolt road wheel and brake disc are attached, and also carries bosses for the cross-axis fixing bolts for the brake calliper.

The primary, vehicle weight bearing, lower wishbone, is widely based and substantially cross braced, and incorporates separate double shear mounting points for the hub carrier and damper lower eye, and a single lug for the anti-roll bar drop link. The outboard end of the wishbone is through bolted to a spherical joint pressed into the lower eye of the hub carrier. The upper wishbone is of simple 'A' form, and houses a replaceable through-bolted spherical joint at its outboard end to connect to the hub carrier. The inboard ends of both upper and lower wishbones use replaceable bonded rubber pivot bushes for maintenance free articulation, with the bush compliance profile tuned to provide the vehicle with accurate and responsive dynamic characteristics. The toe control link is a two part steel forging incorporating an adjustment turnbuckle, and by connecting a rearward extension on the hub carrier to the chassis subframe, a 'toe-in on compression' bump steer characteristic is produced. Through bolted spherical joints are used in each end of the link, and the threaded turnbuckle allows for adjustment of rear wheel alignment. An eccentric cam incorporated at the rear pivot point for the lower wishbone, provides a means of camber adjustment.

The bottom of the Bilstein monotube telescopic damper fixes to the lower wishbone in a double shear arrangement, with the damper top end secured to the subframe via a steel bracket bolted inside the subframe tower. The damper uses a rubber bush in the top eye for noise suppression, and a through bolted spherical steel joint in the lower eye for optimum dynamic response, and is orientated with the damper rod uppermost. The dual rate, concentric coil spring abuts against a lower seat fixed to the damper body, and an upper seat secured to the damper top eye, but also bolted to the subframe, thus relieving the damper top bush of vehicle weight to the benefit of noise and ride refinement. The close coiled end of the spring is mounted lowermost, on the damper body.

A 21mm o.d. tubular steel anti-roll bar is mounted in rubber bushes to the underside of the subframe rearward of the axle line, and curves over each toe-link before connecting to the lower wishbone rear leg via a short ball jointed drop link.

The hub bearing unit, which is common to all four wheels, is fixed to the hub carrier by 4 bolts, and incorporates a wide spaced double row ball bearing and a vehicle speed sensor ring integrated into the inboard seal, whose 48 pole signal is picked up by a sensor mounted in the rear of the hub carrier. This data is used for the anti-lock brake, vehicle stability, engine management and speedometer functions.

DJ.2 - GEOMETRY & ADJUSTMENTS

Provision is made for the adjustment of wheel alignment and camber. Under normal service conditions, no periodic scheduled check of the geometry is necessary, with a full geometry check required only after suspension repair, or if excessive tyre wear is evident, or handling deficiencies encountered. Before any measurements or adjustments are made, it is essential first to set the vehicle to its 'mid-laden' ride height, approximating to driver and passenger and a half/full tank of fuel. This will require the vehicle to be ballasted or tied down:

Type		Independent. Upper and lower wishbone; co-axial coil spring/telescopic damper; toe-link; anti-roll bar
Mid-laden ride height (2 x 75 kg occupants + full fuel tank)		- set car to this height before measuring geometry:
	- front	125 mm below front end of chassis siderail
	- rear	147 mm below rear end of chassis siderail
Camber	- optimum	- 1.6°
	- tolerance range	- 1.8° to - 1.5° max. side/side 0.2°
Alignment	- optimum	1.5 mm toe-in each side
	- tolerance range	1.4 to 1.8 mm toe-in each side max. side/side 0.3 mm
Thrust angle	- optimum	Zero
	- tolerance	0.05°



**Alignment**

Wheel alignment refers to the parallelism of the wheels when viewed from above and is crucial to vehicle stability, handling and tyre wear. It is measured either by the angle a wheel makes with the vehicle centre line, or the difference in dimension between the wheel rim to wheel rim measurement at the front and rear of the wheel at hub centre height. The wheels are said to 'toe-in' when the wheel paths converge ahead of the vehicle, and 'toe-out' when they diverge. Rear wheel alignment should be measured only using equipment which measures **individual** rear wheel alignment relative to the car centreline. Wheel alignment is designed to vary with suspension travel ('bump steer') and the base setting should be measured only at the specified mid laden ride height.

It is possible to accurately measure individual wheel alignment using a pair of long straight bars or round section elastic in conjunction with 4 axle stands or similar. Any bars used must be longer than the length of the car, and be suitably stiff and straight.

Set up the bars or elastic on each side of the car at wheel centre height as shown on the diagram, so that  $A = A$ ,  $B = B$  and  $C = C$ .

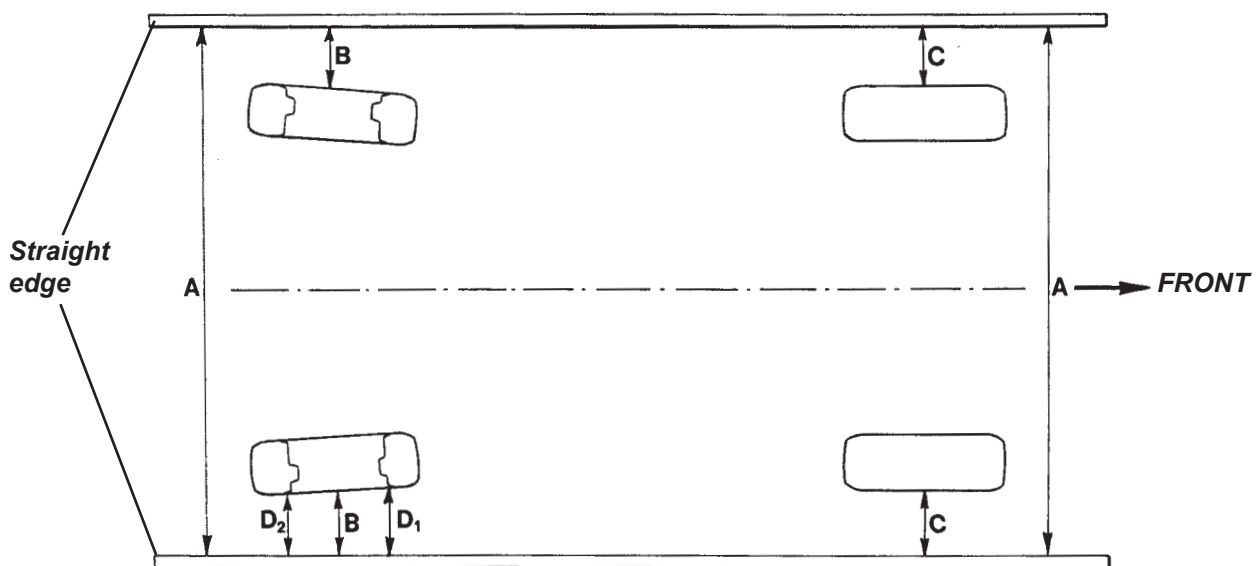

d21

Measure the distance from the bar to the rim of the wheel concerned at the front and rear of the centre line of the wheel ( $D_1$ ,  $D_2$ ). If the front dimension,  $D_1$ , is greater than the rear dimension,  $D_2$ , the wheel has TOE-IN. If the rear dimension is greater than the front dimension, the wheel has TOE-OUT. The difference between the two measurements is the amount the wheel has toe-in or toe-out.

Wheel alignment is adjusted via the toe control link which is equipped with a turnbuckle at its centre. Slacken both locknuts, and turn the buckle as necessary to increase or decrease the effective length of the link. As a guide, lengthening the link rod by a turn of one 'flat' (one sixth of a turn) will increase toe-in by approximately 1.6 mm.

After adjustment, hold each section of the toe-link in turn using the flats provided, whilst tightening each of the two locknuts to 45 Nm. Ensure that the axes of the toe-link pivot bearings are parallel.



**Camber Adjustment**

Camber is the angle from vertical of the wheel when viewed from the rear, and is said to be negative when the wheel leans inwards at the top (positive when leaning outwards).

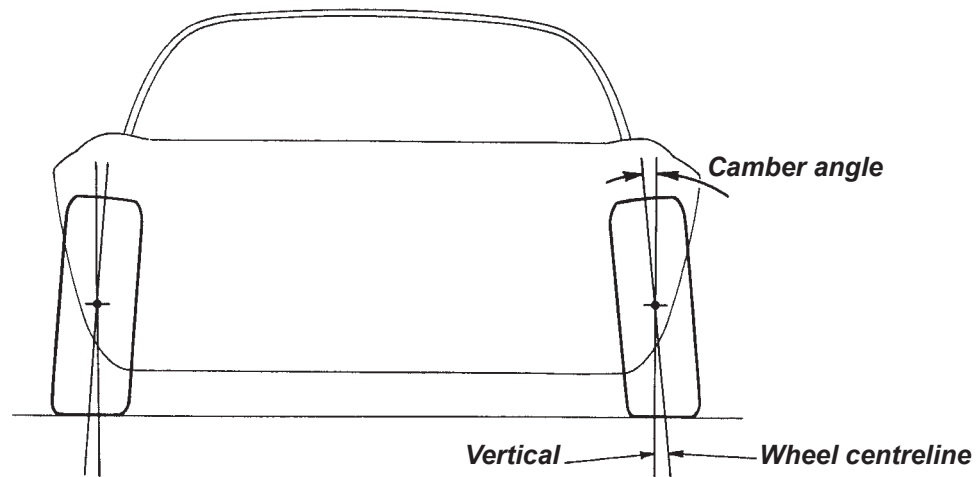

c29

The primary purpose of camber is to achieve the maximum efficiency of the tyre under cornering loads and body roll, with the specification closely allied to a particular wheel/tyre combination. The camber angle changes with suspension travel, becoming more negative on bump, and should be measured only at the specified ride height. Incorrect camber can result in handling deficiencies and excessive tyre wear.

**Illustration TBA**

An eccentric cam at the rear inboard pivot of each lower wishbone provides a means of camber adjustment. The pivot bolt is inserted from the rear, with the bolt head featuring an integral eccentric cam, and with a corresponding eccentric camplate clamped beneath the nut on the front side of the rear pivot. The camplate is keyed to the bolt via a tongue and groove feature to ensure alignment between the two cams. Each cam is constrained by vertical guides in a riveted insert in the subframe, whereas the pivot bolt hole in the subframe is slotted horizontally. Thus by turning the bolt (and eccentric cams) the wishbone pivot axis may be moved inboard or outboard.

When adjusting camber, note that the horizontal movement produced is not linear, but accords with simple harmonic motion. After adjustment, ensure that the pivot bolt is tightened to 86 Nm. Be aware that any camber adjustment will also affect wheel alignment, which must subsequently be checked and/or reset (see above).



DJ.3 - WISHBONE PIVOT BUSHES & SPHERICAL JOINTS

**Pivot Bushes**

The upper and lower wishbone pivot bushes are bonded rubber type with a plastic flanged outer sleeve, an alloy inner sleeve, and an aluminium interleaf sleeve within the rubber bush to control the flexing characteristic. The rubber material specification has been selected to optimise the handling/refinement balance. The flanged end of the bush incorporates a snubbing feature to limit the axial distortion of the bush, with each bush arranged to resist braking forces transmitted through the suspension; Both top wishbone bushes are inserted from the front, and both bottom wishbone bushes from the rear. A chamfer is provided in the wishbone bore for this purpose.

The bushes may be pressed out of the wishbone eyes, and new bushes fitted using suitable press tool dollies. Smear the outer surface of the new bush with IPC 'P-80' rubber lubricant emulsion (A082C6042V) to ease fitment, and assemble in the direction detailed above.

**To be revised**

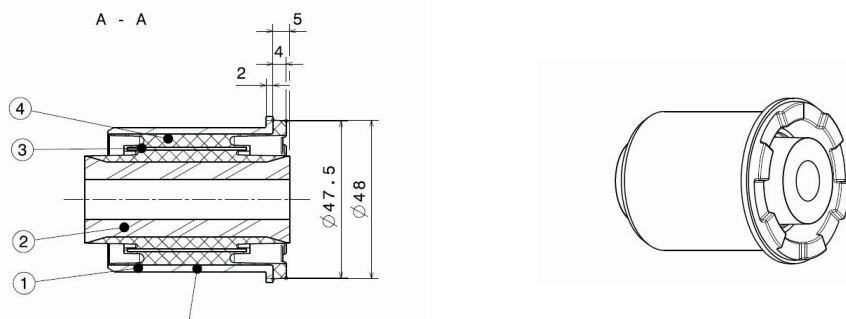

**Damper Upper Bush**

The upper eye of the damper houses a bonded rubber bush, with a steel outer sleeve and an alloy inner sleeve. The bush may be replaced using suitable press tools.

**Spherical Joints**

Through bolted spherical joints are used at the outboard ends of the upper and lower wishbones, both ends of the toe control links, and in the lower eye of the dampers. All joints have an outside diameter of 40mm apart from the lower wishbone joint (pressed into the hub carrier) which is 47mm. Spherical joints are maintenance free, but may be replaced using suitable press tools.

DJ.4 - ANTI-ROLL BAR

A 21mm o.d. tubular steel anti-roll bar is mounted beneath the rear subframe behind the axle line, in rubber bushes retained by extruded alloy clamps. One clamp secures the bar at each side to the bottom surface of the subframe longeron via two bolts tapping into a steel nutplate riveted inside the longeron. Each end of the bar curves over the toe-link before connecting to a lug on the lower wishbone rear leg via a short ball jointed drop link. A pair of washers crimped to the bar, bear against the outboard sides of the mounting bushes to provide lateral location of the bar.

The drop link ball joints require no maintenance, and are replaceable only as part of the handed drop link assembly. The chassis mounted bushes are lubricated with rubber grease on assembly, but require no routine maintenance.

**ARB illustration****DJ.5 - SUSPENSION DISASSEMBLY/ASSEMBLY**

The suspension may be disassembled without the use of any special tools other than spring compressor clamps if the spring and damper are to be separated. If the hub carrier is to be removed, necessitating withdrawal of the driveshaft, it is recommended first to release the driveshaft nut before dismantling the brakes, in order that the brakes may be used to react against the release torque.

With the car on a wheel free lift and with the rear wheels and engine undertray removed:

**Hub Unit**

1. With the parking and footbrakes firmly applied, remove the driveshaft nut (both RH thread).
2. Release the two bolts securing the brake calliper to the hub carrier, release the flexible hose from the top wishbone, and support the calliper aside without straining the brake hose.
3. Check that the parking brake is released, back off the brake shoe adjuster, remove the two countersunk retaining screws and withdraw the brake disc/drum from the hub.
4. Release the single screw securing the wheel speed sensor, and withdraw the sensor from the hub carrier.
5. Release the four hex. head securing bolts and withdraw the hub unit from the hub carrier and driveshaft. Note that this unit is common to all four wheels.

**Parking Brake Backplate**

6. Release the parking brake cable from the backplate actuating lever. Remove the three bolts securing the backplate to the hub carrier and withdraw the backplate complete with brake shoes.

**Hub Carrier**

7. Remove the bolt securing the toe-link to the hub carrier, and separate from the clevis.
8. Remove the bolt securing the top wishbone to the hub carrier, and that securing the lower wishbone to the hub carrier, and withdraw the carrier from the car.

**Damper and Spring**

9. Remove the bolt securing the lower end of the damper to the lower wishbone, noting and retaining the steel washers fitted between the spherical joint and wishbone.



10. Release the two bolts securing the spring top abutment plate to the inside of the subframe tower, and the single bolt (captive nut) securing a leg on the plate to the front face of the tower. Withdraw the complete spring/damper/abutment plate assembly.
11. Using spring compressor clamps and taking all suitable safety precautions, unload the spring seats and remove the bolt securing the damper top eye to the spring top abutment plate and separate the three components, noting the spring top seat cushion. Unload the spring compressor clamps.

### Anti-Roll Bar

12. Release the drop link from each lower wishbone and/or the anti-roll bar.
13. Remove the two bolts securing each of the two alloy clamps to the subframe (riveted nut plates), and withdraw the ARB.

### Upper and Lower Wishbones

14. Remove the two pivot bolts securing the top wishbone, and withdraw the wishbone. Note that the top wishbone is not handed, so should be marked accordingly if both sides are removed and are to be refitted.
15. Before releasing the lower wishbone rear pivot, match mark the eccentric cam to aid re-assembly. Remove the cam bolt and cam, release the front pivot bolt and withdraw the lower wishbone.
16. Release the inboard pivot bolt and withdraw the toe-link. Note that the toe-link is not handed, so should be marked accordingly if both sides are removed and are to be refitted. The shorter toe-link tube is fitted outboard.

### Reassembly

Re-assemble the suspension in reverse order to disassembly with the following notes:

- Take care to assemble each pivot bolt with the correct washers/snubbers/spacers as noted on removal.
- Smear the shank of each pivot bolt with PBC grease to inhibit corrosion and facilitate subsequent servicing, but do not allow grease contamination of the threads.
- Where bolts are threaded into captive nuts with no secondary locking mechanism, apply a suitable thread-locking compound. If separate self-locking nuts are used, assess the locking torque and renew the nuts in any case of doubt. The ARB drop link ball pin self locking nuts should always be renewed.
- Take care to match mark and refit the eccentric cam adjusters on the lower wishbone rear pivot to facilitate subsequent geometry checking and adjustment.
- Lubricate the rubber type anti-roll bar mountings with rubber grease on assembly.
- Adjust the brake shoes and pump the brake pedal to re-position the pads before driving the car.
- If the car suffers a suspension impact sufficient to damage a wheel rim, careful attention should be paid to all related suspension components, and replacement parts fitted in any cases of doubt.

The Service Schedule specifies that the security of the front and rear suspension is checked at each service. For cars used on race tracks, or in similar conditions, suspension components and torque checks should be carried out between sessions. This operation requires that all the principal suspension pivot bolts are torque checked, noting the following points:

Where a bolt is tapped into a housing or weldnut, and relies on a thread locking compound for security, be aware that if the bolt is disturbed, the locking compound must be re-applied. The following procedure should be adopted for all such fixings:

- Check the torque of the fixing.
- If the specified torque is attained without the fixing being disturbed (moving), take no further action.
- If the bolt moves, the locking action of the thread adhesive will have been compromised. Remove the bolt completely, clean off all old adhesive using a wire brush and acetone, and apply new adhesive as specified.
- Refit the bolt and tighten to the specified torque.

If for any reason a bolt is found to have become loose, and the car has been operated for any period in this condition, the bolt should be renewed as a standard precaution and related components carefully inspected for hole ovality or wear.



**Torque Settings:**

	<b>Nm</b>	
- Upper and lower wishbone pivot bolts	86	
- Upper wishbone to hub carrier	135	
- Lower wishbone to hub carrier	135	
- Toe-link outer ball joint to hub carrier	135	
- Toe-link inner ball joint to subframe	135	
- Toe-link turnbuckle locknuts	45	
- Damper to lower wishbone	135	
- Damper to upper abutment bracket	86	
- Spring top abutment bracket to subframe	24	- upper
	45	- lower
- Anti-roll bar drop link ball joints	38	
- Anti-roll bar clamps to subframe	45	
- Hub bearing unit to hub carrier	70	Use Permabond A130
- Brake calliper to hub carrier	86	Use Permabond A130
- Speed sensor to hub carrier	5	
- Driveshaft nut to hub	300	
- Parking brake backplate to hub carrier	45	
- Brake disc retaining screw	10	
- Wheel bolts	105	

DJ.6 - REAR WHEEL BEARINGS

The hub bearing unit, which is common to all four wheels, is fixed to the hub carrier by 4 hex. head bolts, and incorporates a double row ball bearing with the inner race of the outboard bearing formed directly in the hub forging, and the inner race of the inboard bearing retained by a swaging operation on the hub flange. Inboard and outboard grease seals are included in the assembly, with a 48 pole vehicle speed sensor ring integrated into the inboard seal, whose signal is picked up by a sensor mounted in the rear of the hub carrier.

If there is found to be any discernible free play in the hub bearing, or any roughness, or if tight spots can be felt, or any untoward noise heard, or any signs of lubricant expulsion are evident, the hub assembly should be replaced - there is no provision for adjustment or replacement of the bearings.

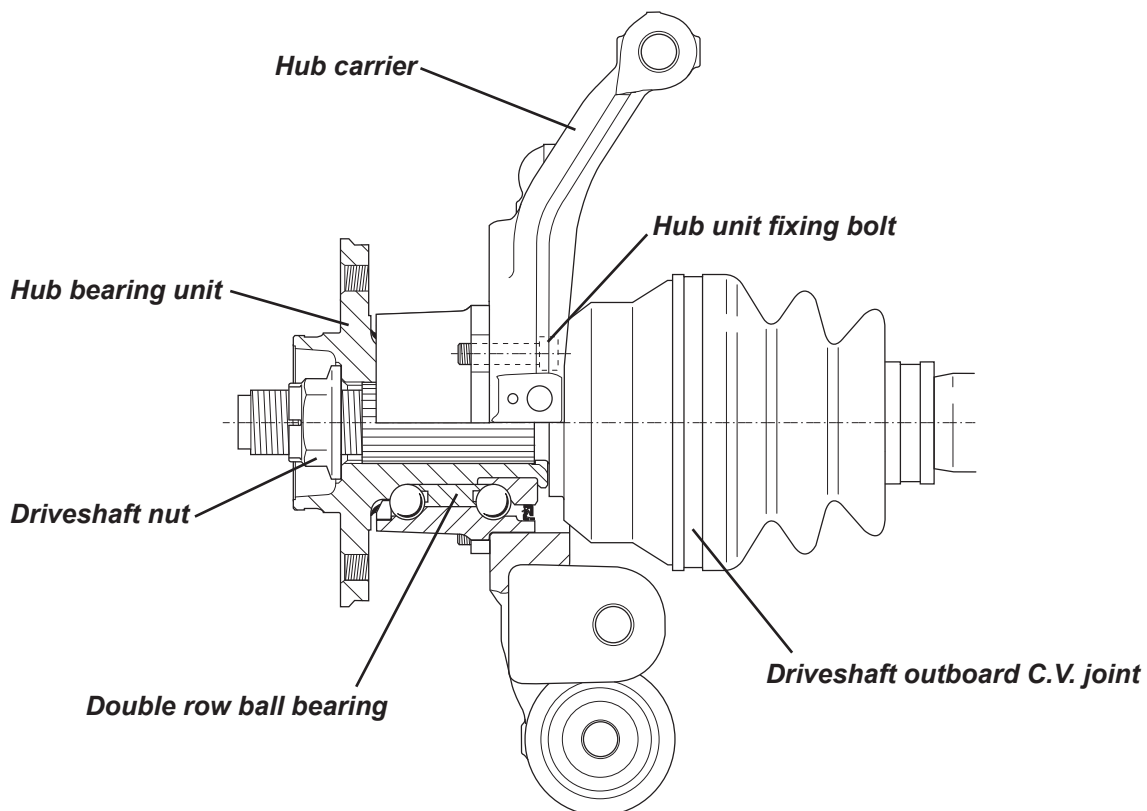

d52





### To Replace Hub Bearing Assembly

With the car on a wheel free lift and with the rear wheel and engine undertray removed:

1. Firmly apply the parking and footbrakes, and remove the driveshaft nut (both RH thread).
2. Release the two fixing bolts, and remove the brake calliper from the hub carrier. Support clear of the brake disc without straining the flexible hose. Check that the parking brake is released, back off the brake shoe adjuster, remove the two countersunk retaining screws and withdraw the brake disc/drum from the hub.
3. Using a Torx socket, release the four bolts securing the hub bearing unit to the hub carrier, and withdraw.
4. Fit the new hub bearing unit to the hub carrier and driveshaft, apply Permabond A130 (A912E7033) to the threads and retain the unit with the four Torx bolts tightened to 70 Nm.
5. Refit the brake disc and calliper, using Permabond A130 (A912E7033) on the threads of the calliper fixing bolts and torque tightening to 86 Nm.
6. Adjust the parking brake shoes and pump the brake pedal to reposition the pads before driving the car.



**ENGINE**

SECTION EJ

	<u>Sub-Section</u>	<u>Page</u>
Introduction	EJ.1	3
Air Cleaner Element Inspection/Replacement	EJ.2	3
Engine Oil & Filter Change	EJ.3	4
Auxiliary Drive Belt	EJ.4	5
Engine Removal/Replacement	EJ.5	5
Engine Special Tools	EJ.6	7
Engine Repair (CD T000T1506)	EJ.7	7



EJ.1 - INTRODUCTION

**General Layout**

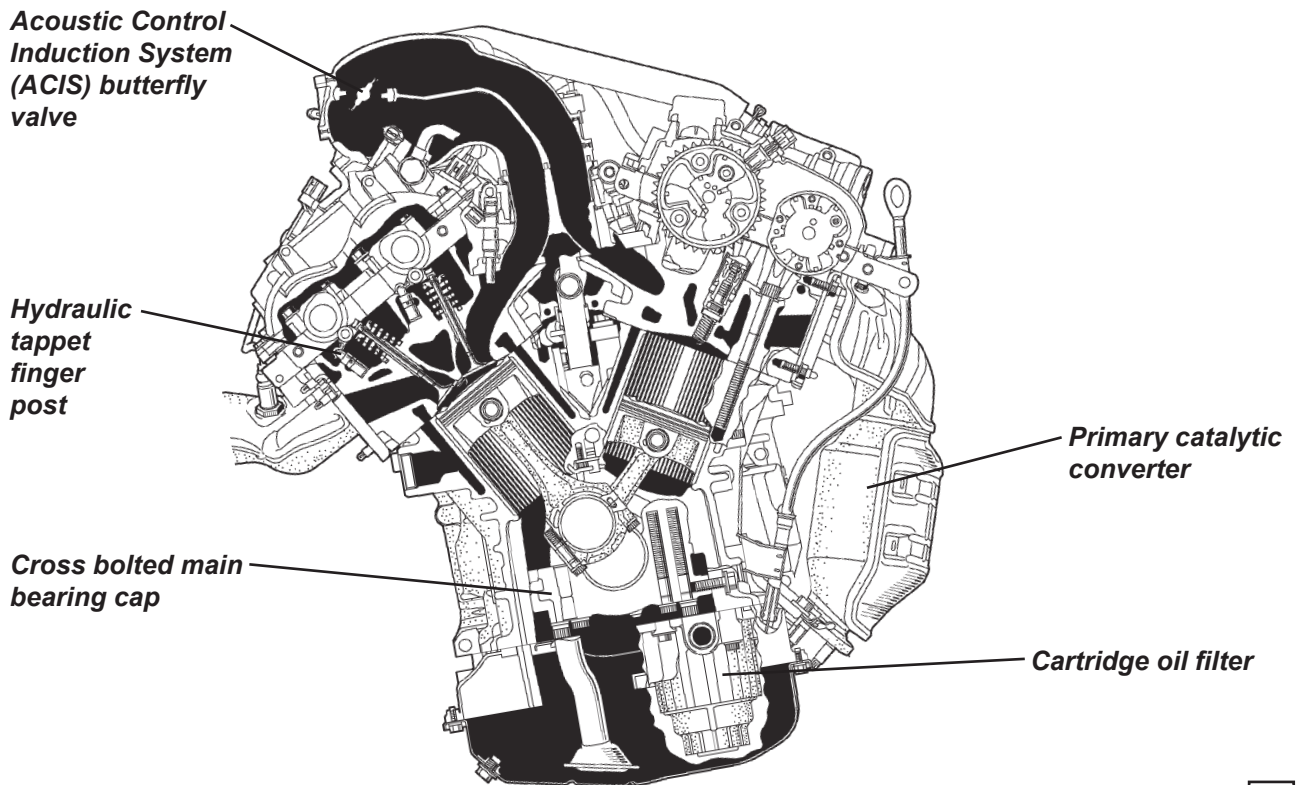
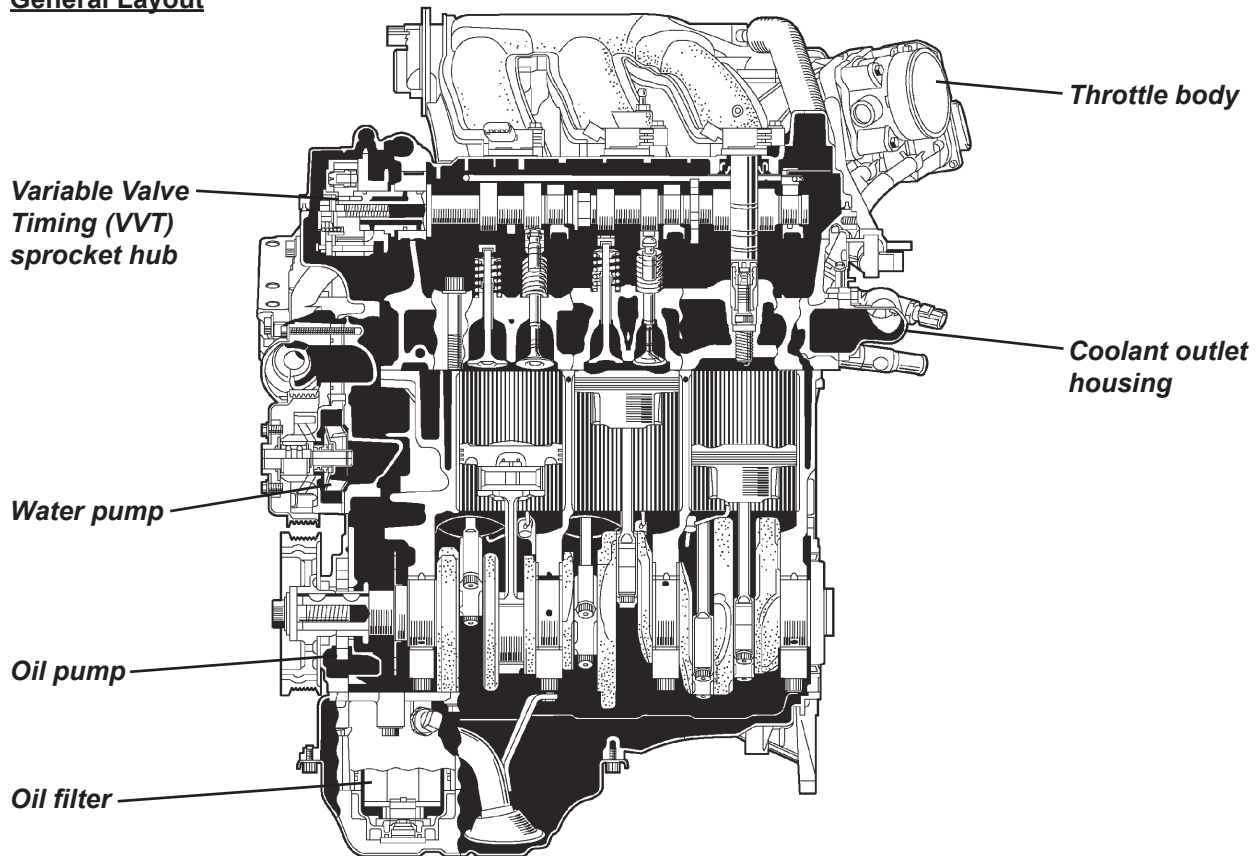

e237



## EJ.1 - INTRODUCTION

### **Terminology**

The powertrain of the Eagle is mounted transversely, with the crankshaft of the engine running parallel to the rear axle line. The front of the engine is to the right of the engine bay and the rear to the left. When referring to powertrain components, this logic will be used, e.g. the left hand side of the engine is towards the front of the engine bay.

### **General Description**

The 2GR-FE engine fitted to the Eagle is supplied by Toyota, and comprises a 3.5 litre 60° V6 unit mounted transversely (front of the engine towards the right) in the 'mid engine' position between the cabin and rear wheel axis. The cylinder block/crankcase and cylinder heads are cast in aluminium alloy with the block featuring an open deck construction and integral cast-in iron liners. The forged steel crankshaft runs in 4 main bearings, with each of the 3 crankpins accommodating two forged steel connecting rods, those of the RH cylinder bank foremost. Each cylinder head houses twin overhead camshafts operating two inlet and two exhaust valves per cylinder, via roller followers mounted in steel fingers, the pivot posts of which provide for zero valve clearances by hydraulic means. The bifurcated ports are arranged with the inlets positioned inside the 'V' and the exhaust ports outboard. The inlet camshafts are driven by a single roller chain from the crankshaft nose, with each exhaust cam driven by a short, link chain from its neighbouring inlet camshaft.

In order to optimise power, economy, emissions and noise, the engine control system includes; dual VVT-i (Variable Valve Timing - intelligent) to provide phase shifting of both inlet and exhaust valve timing; ACIS (Acoustic Control Induction System) to vary the effective intake tract length to the benefit of both high and low speed power output; ETCS - i (Electronic Throttle Control System - intelligent) to facilitate traction control, skid control and cruise control; AICS (Air Intake Control System) to reduce intake noise in the low to mid range of engine speed without sacrificing efficiency at high engine speed. The engine management system is programmed by Lotus using the T4e controller.

The engine is mated to a type EA60 6-speed manual transmission supplied by Toyota, and installed in the engine bay with transmission on the left hand side. Primary mountings for the power unit pick up off the front of the engine and to the top rear of the transmission case, and connect with the suspension towers on the rear subframe via voided elastic isolators. Secondary engine steady mountings are used to control powertrain roll under drive torque and inertia effects, and are fitted low down on either side of the block, attaching to the chassis rear crossmember and to the subframe via elastic isolators.

## EJ.2 - AIR CLEANER ELEMENT INSPECTION/REPLACEMENT

To inspect the air cleaner element, the airbox cover complete with resonance chamber, may be removed from the throttle body and air cleaner base unit without disturbing the clamshell.

1. Remove the LHR wheel.
2. Release the clamp securing the convoluted intake hose from the airbox to the throttle body.
3. Release the rear bank cam cover breather hose from the convoluted intake hose.
4. Release two vacuum hoses from the airbox reservoir, one from an intake tract), the other to the intake flap valve solenoid.
5. Unplug the harness connector from the airflow sensor.
6. From within the LHR wheelarch, remove the access panel in the wheelarch liner and release the two overcentre clips on the airbox. Unhook the airbox cover from the base and withdraw. Thoroughly clean the cover.
7. Clean all around the airbox base before removing the cleaner element, taking care to avoid contaminating the base unit with dust or dirt. Fit the new element into the base, and refit the cleaned cover, ensuring that the moulded tongues are fully engaged in the base unit. Fasten the two overcentre clips, and check



again for correct mating.

8. Continue re-assembly in reverse order to removal.

### EJ.3 - ENGINE OIL & FILTER CHANGE

The engine oil hex. head drain plug is located in the base of the pressed steel sump. Remove the plug to drain the sump immediately after a run when the oil is warm and the impurities are still held in suspension.

#### **⚠ WARNING**

- **Engine oil is hazardous to your health and may be fatal if swallowed.**
- **Take all suitable precautions to guard against scalding from the hot oil.**
- **Prolonged and repeated contact with used engine oil may cause serious skin disorders, including dermatitis and cancer.**
- **Use protective gloves to avoid contact with skin as far as possible and wash skin thoroughly after any contact.**
- **Keep out of reach of children.**

Allow the oil to drain completely before cleaning the drain plug, fitting a new sealing ring, and tightening securely. Refill with the recommended lubricant (see section OK) via the oil filler on the camshaft cover, to the top mark on the dipstick, allowing several minutes for the oil to drain through to the sump before checking the level. Take care not to overfill. Refit the oil filler cap securely, and check the oil level again when the engine is fully warm.

#### *Oil Filter*

The cartridge type oil filter is mounted at the right hand front of the engine, and is accessible only from beneath. The filter should be renewed along with the engine oil, at intervals specified in the Maintenance Schedule.

The oil filter housing incorporates a drain plug to minimise potential oil spillage;

- Unscrew the drain plug (square socket) from the filter housing cap and collect the small amount of oil released.

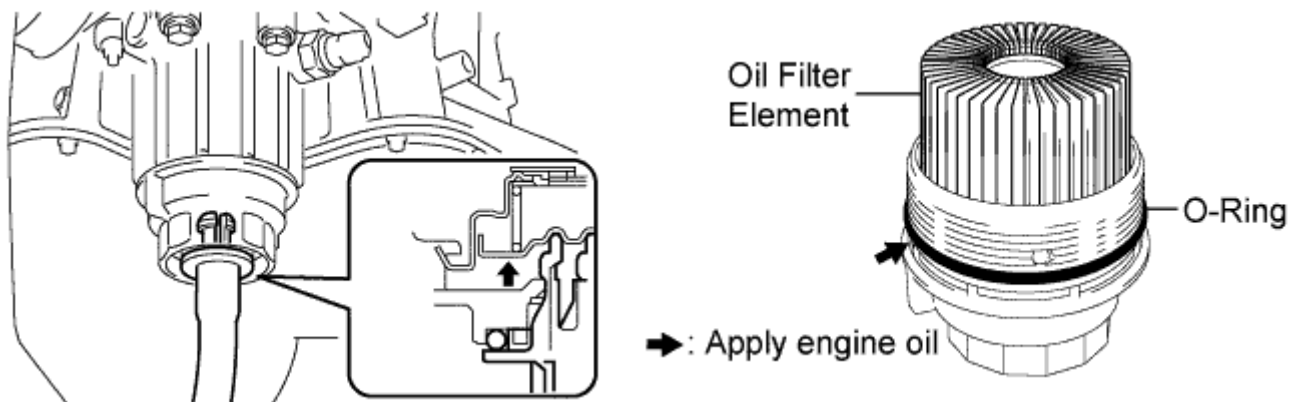

- Connect a length of 15mm i.d. hose to the drain pipe supplied with the new filter. Insert the pipe into the base of the filter housing with the 'O' ring on the top side of the tube flange, and push upwards until it clicks into position and opens the spring loaded drain valve. Collect the draining oil.
- Remove the drain tube by pulling sideways and down.
- Using special tool T000T1511, unscrew the cap from the filter housing. Discard the filter element and filter cap 'O' ring.
- Thoroughly clean the filter cap, filter housing and drain plug.
- Fit the new 'O' ring supplied with the new filter element into the cap groove, and lubricate with engine oil. Fit the new filter element into the cap, and install the filter and cap into the housing, ensuring that the 'O'



- ring does not become displaced.
- Using special tool T000T1511, torque tighten the cap to 25 Nm. Check that there is no clearance between cap and housing.
- Lubricate the small 'O' ring supplied with the new filter with engine oil, and fit into the groove in the filter housing. Fit the filter drain plug and tighten to 13 Nm.
- Check the oil level (see above) before starting the engine and restricting to idle speed until the oil pressure tell tale is extinguished. Check for oil leaks with the engine running. Stop the engine when fully warm and re-check oil level.

### EJ.4 - AUXILIARY DRIVE BELT

A single serpentine multi-rib auxiliary belt is used to transfer drive from the crankshaft nose pulley to the power steering pump, water pump, alternator and a.c. compressor. An automatic type belt tensioner is provided in the form of an idler pulley mounted on a spring loaded arm. At each service interval, the whole length of belt, on both the inside and outside surfaces, should be examined for any evidence of perishing, cracking, chafing, splitting, tearing, delamination, contamination or other indications of undue wear or deterioration. In any cases of doubt, the belt should be renewed.

#### *Auxiliary Belt Replacement*

- Remove the RH rear wheel and wheelarch liner.
- If the original belt is to be refitted (renewal is recommended), mark the direction of rotation on the belt before removal.
- Using a 14 mm hexagonal socket and long bar, rotate the tensioner pulley counterclockwise to relieve the tension on the belt.
- Align the hole in the arm with the corresponding drilling in the baseplate and insert a 5mm rod or hex. key to hold the tensioner in the released position.
- Slide the belt off the pulleys.

When reinstalling the belt, retain the original direction of rotation, and ensure that the belt ribs are correctly located on each drive pulley, before finally fitting over the tensioner pulley. Rotate the tensioner counterclockwise to relieve tension and remove the locking pin.

### EJ.5 - ENGINE REMOVAL/REPLACEMENT

The engine and/or transmission can be removed only as a combined unit, and should be lifted out from above after removing the rear clamshell:

1. *Preparation:* Remove both rear wheels, the diffuser and engine undertray. Remove the rear clamshell (see sub-section BV.6).
2. *Drain fluids:* Drain the transmission oil and the cooling system. De-pressurise fuel system (see sub-section LN.3). Recover refrigerant gas.
3. *Driveshafts and hub carriers:*  
At each side:
  - Remove the rear brake calliper and support aside without straining the hydraulic hose.
  - Disconnect the parking brake cable from the brake backplate.
  - Disconnect the wheel speed sensor cable.
  - On the RH driveshaft, release the two bolts securing the extension shaft bearing to the engine mounted bracket.
  - Release the fixings securing the top and bottom wishbones and toe-link to the hub carrier.
  - Withdraw the complete RH hub carrier and driveshaft assembly, taking care not to damage the transmission output shaft oil seal.
  - The left hand driveshaft is retained in the transmission by a round section circlip. Use a suitable slide hammer with a forked adaptor or use pry bar to apply a shock force to the body of the inboard CV joint to release the driveshaft. DO NOT apply a pulling or extension force to the driveshaft assembly, or the



CV joints will be damaged and require replacement. Apply pressure only to the body of the inboard joint. Withdraw the complete LH hub carrier and driveshaft assembly, taking care not to damage the transmission output shaft oil seal.

4. *Heat shields:* Remove the boot box and battery box heatshields from the subframe.
5. *SBMF struts:* Remove both LH and RH struts bracing the Seat Belt Mounting Frame to the subframe to provide better access to the powertrain.
6. *Airbox:* Remove the complete intake airbox together with trunking.
7. *Header tank:* Release the header tank bracket from the subframe, release the recirc. pump bracket and hose, heater return hose, radiator return hose and brake servo vacuum hose from the engine, and secure all plumbing aside.
8. *Purge pipe:* Release the purge pipe from the charcoal canister.
9. *Fuel pipe:* After checking that the fuel system is de-pressurised, and taking suitable precautions to absorb residual fuel, disconnect the fuel feed pipe from the fuel rail.
10. *Engine harness:* From the LH rear corner of the cabin, disconnect the engine harness from the ECU and release the adjacent earth braid. Feed the cables and grommet through the rear bulkhead.
11. *Gearchange cables:* Release the gearchange cables from the transmission levers and abutment brackets. Release any cable guides and restraints.
12. *Clutch release:* Release the clutch slave cylinder and the bracket securing the flexible hose to the transmission, and place aside without disturbing the hydraulic line.
13. *Earth braid:* Release the earth braid from the transmission case.
14. *Exhaust:* Release the exhaust downpipe from the catalytic converter.
15. *PAS:* Release the feed and return pipes from the PAS pump and collect the draining fluid.
16. *A.C.:* Disconnect the high and low pressure a.c. pipes from the compressor hoses and plug all ports.
17. *Rad. hose:* Release the radiator feed hose from the thermostat housing.
18. *Hooks:* Fit lifting hooks A132E6182S and A132E6183S to the RH front and LH rear of the engine and support the powertrain on a hoist.
19. *Steady mountings:* At the left hand side of the engine, remove the connecting clevis bolt. At the right hand side of the engine, release the isolator mounting bracket from the engine clevis and subframe.
20. *Engine mounts:* At the transmission end of the powertrain, release the four fixings securing the engine mounting plate to the subframe LH tower, and the isolator clevis bolt. At the front of the engine, release the three fixings securing the engine mounting to the subframe RH tower.
21. *Hoist:* Carefully hoist the powertrain from the chassis, constantly checking for any remaining attachments or snagging. Place the unit on a flat surface and support securely using wooden chocks as necessary.

### *Powertrain Replacement*

To refit the powertrain, reverse the removal procedure, with the following notes:

- Refer to the following torque listing.
- Torque tighten the engine isolator bolts only when all four mountings are secured and the hoist is released.



- Re-charge the air conditioning system (see section PN), refill the power steering and cooling systems, and transmission and engine lubrication.
- After re-assembly of the rear suspension, check camber and wheel alignment.

## EJ.6 - ENGINE SPECIAL TOOLS

Engine Lifting Hook, RH	A132E6182S
Engine Lifting Hook, LH	A132E6183S
Wrench Adaptor, oil filter cap	T000T1511S

## EJ.7 - ENGINE REPAIR

Engine repair information is contained on CD T000T1506 (Toyota SC03T0U) and by following the links:

Insert disc 'XML'

Service Information Directory will automatically open up. If not, open the CD and select:

- rm03t0u
- index HTML

Then;

- Technical Description; New car features
- NM01M0U
- ENGINE
- 2GR-FE ENGINE

Then select from the menu for an overview of the engine features.

Insert disc 'HTML'

Global Service Information Centre will open up. Select:

- ENGINE

From menu section relating to the 2GR-FE engine, select topic required. Be aware of installation differences for the Lotus application.





ENGINE MANAGEMENT

SECTION EMR

	<u>Sub-Section</u>	<u>Page</u>
Diagnostic Trouble Code List	EMR.1	3
CAN Bus Diagnostics; Lotus TechCentre	EMR.2	80



NOTES

Cylinder Numbering - viewed from above:

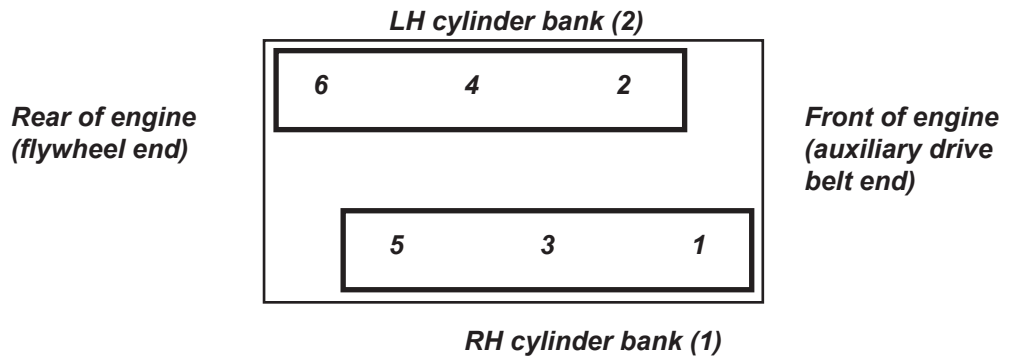



EMR.1 - DIAGNOSTIC TROUBLE CODE (DTC) LIST

<b>DTC</b>	<b>Fault description</b>	<b>Page</b>
P0011	A Camshaft Position - Timing Over-Advanced or System Performance - Bank 1	11
P0012	A Camshaft Position - Timing Over-Retarded - Bank 1	11
P0014	B Camshaft Position - Timing Over-Advanced or System Performance - Bank 1	11
P0015	B Camshaft Position - Timing Over-Retarded - Bank 1	11
P0016	Crankshaft Position - Camshaft Position Correlation - Bank 1 Sensor A	12
P0017	Crankshaft Position - Camshaft Position Correlation - Bank 1 Sensor B	12
P0018	Crankshaft Position - Camshaft Position Correlation - Bank 2 Sensor A	12
P0019	Crankshaft Position - Camshaft Position Correlation - Bank 2 Sensor B	12
P0021	A Camshaft Position - Timing Over-Advanced or System Performance - Bank 2	11
P0022	A Camshaft Position - Timing Over-Retarded - Bank 2	11
P0024	B Camshaft Position - Timing Over-Advanced or System Performance - Bank 2	11
P0025	B Camshaft Position - Timing Over-Retarded - Bank 2	11
P0076	Intake Valve Control Solenoid Circuit Low - Bank 1	13
P0077	Intake Valve Control Solenoid Circuit High - Bank 1	13
P0079	Exhaust Valve Control Solenoid Circuit Low - Bank 1	13
P0080	Exhaust Valve Control Solenoid Circuit High - Bank 1	13
P0082	Intake Valve Control Solenoid Circuit Low - Bank 2	13
P0083	Intake Valve Control Solenoid Circuit High - Bank 2	13
P0085	Exhaust Valve Control Solenoid Circuit Low - Bank 2	13
P0086	Exhaust Valve Control Solenoid Circuit High - Bank 2	13
P0101	Mass or Volume Air Flow Circuit Range/Performance	14
P0102	Mass or Volume Air Flow Circuit Low Input	14
P0103	Mass or Volume Air Flow Circuit High Input	14
P0106	Manifold Absolute Pressure/Barometric Pressure Circuit Range/Performance	-
P0107	Manifold Absolute Pressure/Barometric Pressure Circuit Low Input	16
P0108	Manifold Absolute Pressure/Barometric Pressure Circuit High Input	16
P0111	Intake Air Temperature Sensor 1 Circuit Range/Performance	-
P0112	Intake Air Temperature Sensor 1 Circuit Low	17
P0113	Intake Air Temperature Sensor 1 Circuit High	17
P0116	Engine Coolant Temperature Circuit Range/Performance	19
P0117	Engine Coolant Temperature Circuit Low	19
P0118	Engine Coolant Temperature Circuit High	19
P0122	Throttle Position Sensor 'A' Circuit Low	21
P0123	Throttle Position Sensor 'A' Circuit High	21
P0128	Coolant Thermostat (Coolant Temperature Below Thermostat Regulating Temperature)	-
P0131	O2 Sensor Circuit Low Voltage (Pre Catalyst) - Bank1	25
P0132	O2 Sensor Circuit High Voltage (Pre Catalyst) - Bank1	25
P0133	O2 Sensor Circuit Slow Response (Pre Catalyst) - Bank1	25
P0134	O2 Sensor Circuit No Activity Detected (Pre Catalyst) - Bank1	25
P0135	O2 Sensor Heater Circuit (Pre Catalyst) - Bank1	25
P0137	O2 Sensor Circuit Low Voltage (Post Catalyst) - Bank1	28
P0138	O2 Sensor Circuit High Voltage (Post Catalyst) - Bank1	28
P0139	O2 Sensor Circuit Slow Response (Post Catalyst)	-
P0140	O2 Sensor Circuit No Activity Detected (Post Catalyst) - Bank1	28
P0141	O2 Sensor Heater Circuit (Post Catalyst) - Bank1	28
P0151	O2 Sensor Circuit Low Voltage (Pre Catalyst) – Bank2	25
P0152	O2 Sensor Circuit High Voltage (Pre Catalyst) – Bank2	25
P0153	O2 Sensor Circuit Slow Response (Pre Catalyst) – Bank2	25
P0154	O2 Sensor Circuit No Activity Detected (Pre Catalyst) – Bank2	25
P0155	O2 Sensor Heater Circuit (Pre Catalyst) – Bank2	25
P0157	O2 Sensor Circuit Low Voltage (Post Catalyst) – Bank2	28
P0158	O2 Sensor Circuit High Voltage (Post Catalyst) – Bank2	28
P0159	O2 sensor Circuit Slow Response (Post Catalyst)	-

Continued.....



.....Continued

<b>DTC</b>	<b>Fault description</b>	<b>Page</b>
P0160	O2 Sensor Circuit No Activity Detected (Post Catalyst) – Bank2	28
P0161	O2 Sensor Heater Circuit (post Catalyst) – Bank2	28
P0171	System Too Lean – Bank1	31
P0172	System Too Rich – Bank1	31
P0174	System Too Lean – Bank2	31
P0175	System Too Rich – Bank2	31
P0222	Throttle Position Sensor 'B' Circuit Low	21
P0223	Throttle Position Sensor 'B' Circuit High	21
P0261	Cylinder 1 Injector Circuit Low	33
P0262	Cylinder 1 Injector Circuit High	33
P0264	Cylinder 2 Injector Circuit Low	33
P0265	Cylinder 2 Injector Circuit High	33
P0267	Cylinder 3 Injector Circuit Low	33
P0268	Cylinder 3 Injector Circuit High	33
P0270	Cylinder 4 Injector Circuit Low	33
P0271	Cylinder 4 Injector Circuit High	33
P0273	Cylinder 5 Injector Circuit Low	33
P0274	Cylinder 5 Injector Circuit High	33
P0276	Cylinder 6 Injector Circuit Low	33
P0277	Cylinder 6 Injector Circuit High	33
P0300	Random/Multiple Cylinder Misfire Detected	34
P0301	Cylinder 1 Misfire Detected	34
P0302	Cylinder 2 Misfire Detected	34
P0303	Cylinder 3 Misfire Detected	34
P0304	Cylinder 4 Misfire Detected	34
P0305	Cylinder 5 Misfire Detected	34
P0306	Cylinder 6 Misfire Detected	34
P0327	Knock Sensor 1 Circuit Low	36
P0328	Knock Sensor 1 Circuit High	36
P0332	Knock Sensor 2 Circuit Low	36
P0333	Knock Sensor 2 Circuit High	36
P0335	Crankshaft Position Sensor "A" Circuit Range/Performance	37
P0341	Camshaft Position Sensor "A" Circuit Range/Performance (Bank 1)	38
P0346	Camshaft Position Sensor "A" Circuit Range/Performance (Bank 2)	38
P0351	Ignition Coil "A" Primary/Secondary Circuit	39
P0352	Ignition Coil "B" Primary/Secondary Circuit	39
P0353	Ignition Coil "C" Primary/Secondary Circuit	39
P0354	Ignition Coil "D" Primary/Secondary Circuit	39
P0355	Ignition Coil "E" Primary/Secondary Circuit	39
P0356	Ignition Coil "F" Primary/Secondary Circuit	39
P0366	Camshaft Position Sensor "B" Circuit Range/Performance (Bank 1)	38
P0391	Camshaft Position Sensor "B" Circuit Range/Performance (Bank 2)	38
P0420	Catalyst System Efficiency Below Threshold (Bank 1)	40
P0430	Catalyst System Efficiency Below Threshold (Bank 2)	40
P0441	Evaporative Emission System Incorrect Purge Flow	-
P0442	Evaporative Emission System Leak Detected (small leak)	-
P0444	Evaporative Emission System Purge Control Valve Circuit Open	45
P0445	Evaporative Emission System Purge Control Valve Circuit Shorted	45
P0446	Evaporative Emission System Vent Control Circuit	-
P0447	Evaporative Emission System Vent Control Circuit Open	-
P0448	Evaporative Emission System Vent Control Circuit Shorted	-
P0451	Evaporative Emission System Pressure Sensor/Switch Range/Performance	-
P0452	Evaporative Emission System Pressure Sensor/Switch Low	-

Continued.....



.....Continued

<b><u>DTC</u></b>	<b><u>Fault description</u></b>	<b><u>Page</u></b>
P0453	Evaporative Emission System Pressure Sensor/Switch High	-
P0455	Evaporative Emission System Leak Detected (large leak)	-
P0456	Evaporative Emission System Leak Detected (very small leak)	-
P0461	Fuel Level Sensor "A" Circuit Range/Performance	47
P0462	Fuel Level Sensor "A" Circuit Low	47
P0463	Fuel Level Sensor "A" Circuit High	47
P0500	Vehicle Speed Sensor "A"	50
P0506	Idle Air Control System RPM Lower Than Expected	51
P0507	Idle Air Control System RPM Higher Than Expected	51
P0562	System Voltage Low	53
P0563	System Voltage High	53
P0601	Watchdog	56
P0606	Checksum	56
P0610	Variant Code not Programmed	57
P0628	Fuel Pump Control Circuit Low	59
P0629	Fuel Pump Control Circuit High	59
P0630	VIN not Programmed or Incompatible	60
P0638	Throttle Control Error	61
P0661	Intake Manifold Tuning Valve Control Circuit Low	63
P0662	Intake Manifold Tuning Valve Control Circuit High	63
P1301	Misfire level causing emissions increase	67
P1302	Misfire level causing catalyst system damage	67
P2100	Throttle Actuator Control Motor Circuit/Open	69
P2102	Throttle Actuator Control Motor Circuit Low	69
P2103	Throttle Actuator Control Motor Circuit High	69
P2104	Throttle Actuator Control System – Forced Idle	70
P2105	Throttle Actuator Control System – Forced Engine Shutdown	70
P2106	Throttle Actuator Control System – Forced Limited Power	71
P2107	Throttle Actuator Control Module Processor	71
P2108	Throttle Actuator Control Module Performance	72
P2122	Throttle/Pedal Position Sensor/Switch "D" Circuit Low	72
P2123	Throttle/Pedal Position Sensor/Switch "D" Circuit High	73
P2127	Throttle/Pedal Position Sensor/Switch "E" Circuit Low	73
P2128	Throttle/Pedal Position Sensor/Switch "E" Circuit High	74
P2135	Voltage Correlation Error (Sensors "A" & "B").	74
P2138	Voltage Correlation Error (Sensors "D" & "E").	75
P2173	Throttle Actuator Control System – High Airflow Detected	75

**Non-MIL Fault codes**

P0480	Fan 1 Control Circuit	49
P0481	Fan 2 Control Circuit	49
P0537	A/C Evaporator Temperature Sensor Circuit Low	52
P0538	A/C Evaporator Temperature Sensor Circuit High	52
P0564	Cruise Control Multi-function Input Signal	54
P0571	Brake Switch "A" Circuit	54
P0578	Cruise Control Multi-Function Input "A" Circuit Stuck	54
P0616	Starter Relay Circuit Low	58
P0617	Starter Relay Circuit High	58
P0646	A/C Clutch Relay Control Circuit Low	62
P0647	A/C Clutch Relay Control Circuit High	62
P0806	Clutch Position Sensor Circuit Range/Performance	64
P0807	Clutch Position Sensor Circuit Low	64
P0808	Clutch Position Sensor Circuit High	64

Continued.....



.....Continued

<b>DTC</b>	<b>Fault description</b>	<b>Page</b>
P1113	Air Intake Control Valve Circuit	66
P2602	Coolant Pump Control Circuit Low	68
P2603	Coolant Pump Control Circuit High	68
P2612	A/C Refrigerant Distribution Valve Control Circuit Low	76
P2613	A/C Refrigerant Distribution Valve Control Circuit High	76
B1422	A/C Compressor Lock Sensor Circuit	77
U0101	Lost Communications with TCM	78
U0122	Lost Communications with VDCM	78
U0127	Lost Communications with TPMS	78
U0316	Software Incompatible with VDCM	79

When applicable, reference may be made under the 'Notes' heading to a page in the Toyota service manual. This information should be used only for diagnosis and connection detail of the **sensor**. The Evora uses a Lotus ECU, the connections for which may be found in circuit diagrams in Section MR. Diagnostic Trouble Codes should be read using the Lotus TechCentre.

MR.2 - COMPONENT FUNCTION**Component****Function**

Mass Air Flow Meter	Engine load detection
Intake Air Temperature Sensor	Air temperature detection
Engine Coolant Temperature Sensor	Engine coolant temperature detection
Throttle Position Sensor	Determines engine throttle position
Pedal Position Sensor	Determines pedal position requested by driver
Barometric Pressure Sensor	Barometric pressure detection
O2 Sensor (Front) – Bank 1	Measures oxygen content in exhaust before bank 1 primary catalyst
O2 Sensor (Front) – Bank 2	Measures oxygen content in exhaust before bank 1 primary catalyst
O2 Sensor (Rear) – Bank 1	Measures oxygen content in exhaust after bank 1 primary catalyst
O2 Sensor (Rear) – Bank 2	Measures oxygen content in exhaust after bank 2 primary catalyst
Crankshaft Position Sensor	Determines crankshaft position
Camshaft Position Sensor (Inlet) – Bank 1	Determines bank1 inlet camshaft position
Camshaft Position Sensor (Inlet) – Bank 2	Determines bank 2 inlet camshaft position
Camshaft Position Sensor (Exhaust) – Bank 1	Determines bank 1 exhaust camshaft position
Camshaft Position Sensor (Exhaust) – Bank 2	Determines bank 2 exhaust camshaft position
Knock Sensor – Bank1	Determines bank 1 engine detonation
Knock Sensor – Bank2	Determines bank 2 engine detonation
Fuel Level Sensor	Determines fuel tank level
Air Conditioning Evaporator Temperature Sensor	Evaporator temperature detection
Clutch Pedal Position Sensor	Determines clutch pedal position
Brake Pedal Position Switch	Determines brake pedal position
Cruise Control Multi-function Input	Determines driver request for cruise control
Electronic Throttle Control Motor	Actuates engine throttle
Injector Circuit – Cylinder 1	Regulates fuel injected into cylinder 1
Injector Circuit – Cylinder 2	Regulates fuel injected into cylinder 2
Injector Circuit – Cylinder 3	Regulates fuel injected into cylinder 3
Injector Circuit – Cylinder 4	Regulates fuel injected into cylinder 4
Injector Circuit – Cylinder 5	Regulates fuel injected into cylinder 5
Injector Circuit – Cylinder 6	Regulates fuel injected into cylinder 6
Ignition Circuit – Cylinder 1	Actuates spark plug in cylinder 1
Ignition Circuit – Cylinder 2	Actuates spark plug in cylinder 2
Ignition Circuit – Cylinder 3	Actuates spark plug in cylinder 3
Ignition Circuit – Cylinder 4	Actuates spark plug in cylinder 4
Ignition Circuit – Cylinder 5	Actuates spark plug in cylinder 5
Ignition Circuit – Cylinder 6	Actuates spark plug in cylinder 6
Variable Valve Timing Actuator (Inlet) – Bank 1	Actuates bank 1 inlet camshaft timing control
Variable Valve Timing Actuator (Inlet) – Bank 2	Actuates bank 2 inlet camshaft timing control
Variable Valve Timing Actuator (Exhaust) – Bank 1	Actuates bank 1 exhaust camshaft timing control
Variable Valve Timing Actuator (Exhaust) – Bank 2	Actuates bank 2 exhaust camshaft timing control
Variable Intake Manifold Actuator	Actuates variable intake manifold
Primary Catalyst – Bank 1	Removes pollutants from exhaust
Primary Catalyst – Bank 2	Removes pollutants from exhaust
Secondary Catalyst	Removes pollutants from exhaust
Evaporative Emission Control System Purge Control Valve	Regulates fuel tank vapour flow into inlet manifold
Fuel Pump Relay	Actuates fuel pump
Starter Relay	Actuates engine starter motor



**Component**

**Function**

Cooling Fan 1 Relay	Actuates cooling fan 1
Cooling Fan 2 Relay	Actuates cooling fan 2
Air Conditioning Control Relay	Actuates air conditioning compressor
Air Conditioning Control Valve	Regulates air conditioning compressor load
Coolant Recirculation Pump	Actuates coolant recirculation pump
Noise Flap Solenoid	Actuates air intake flap vacuum control
ABS	Provides vehicle wheel speed information
Battery	Provides electrical power





EMR.3 - COMPONENT LOCATION

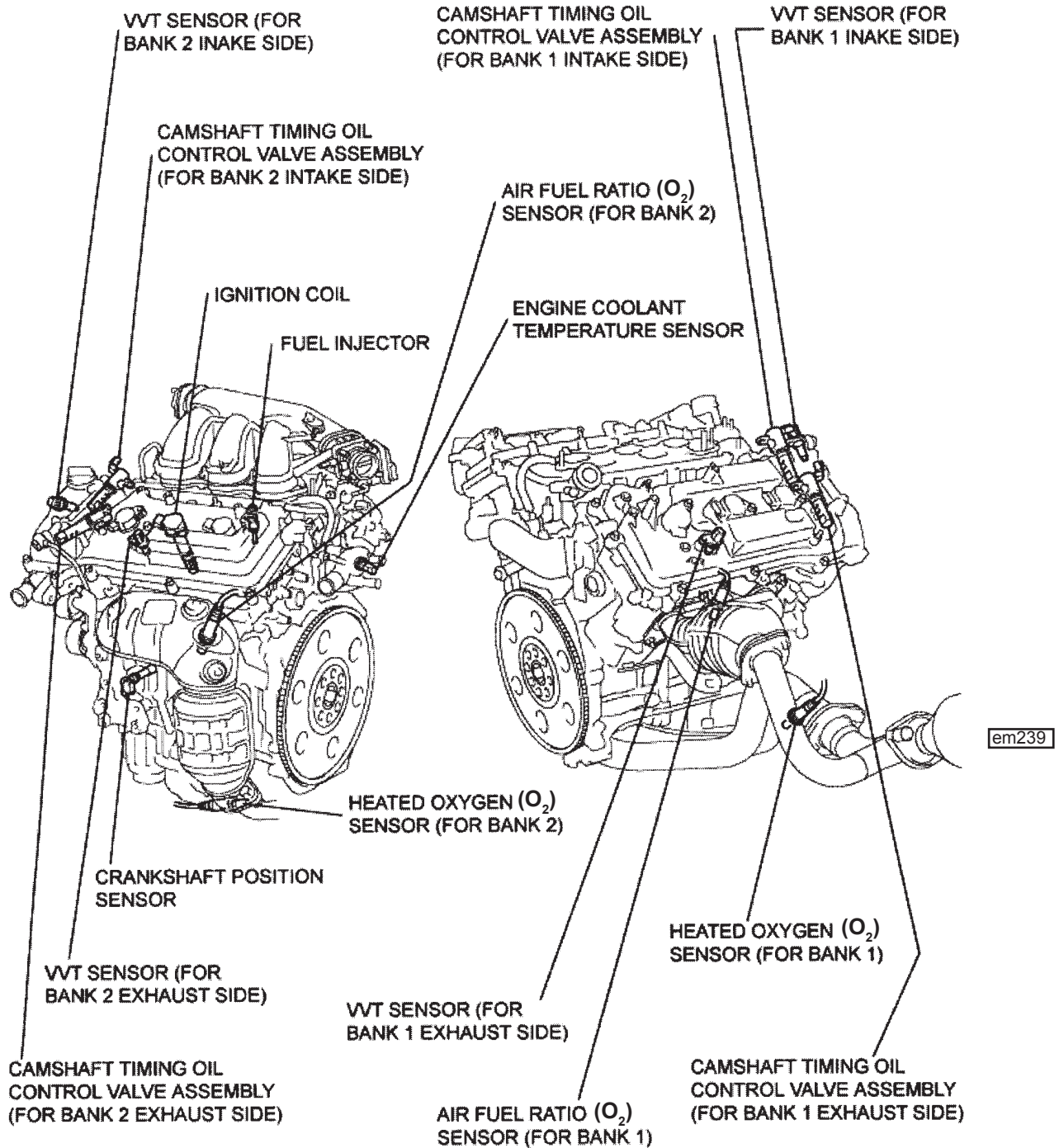

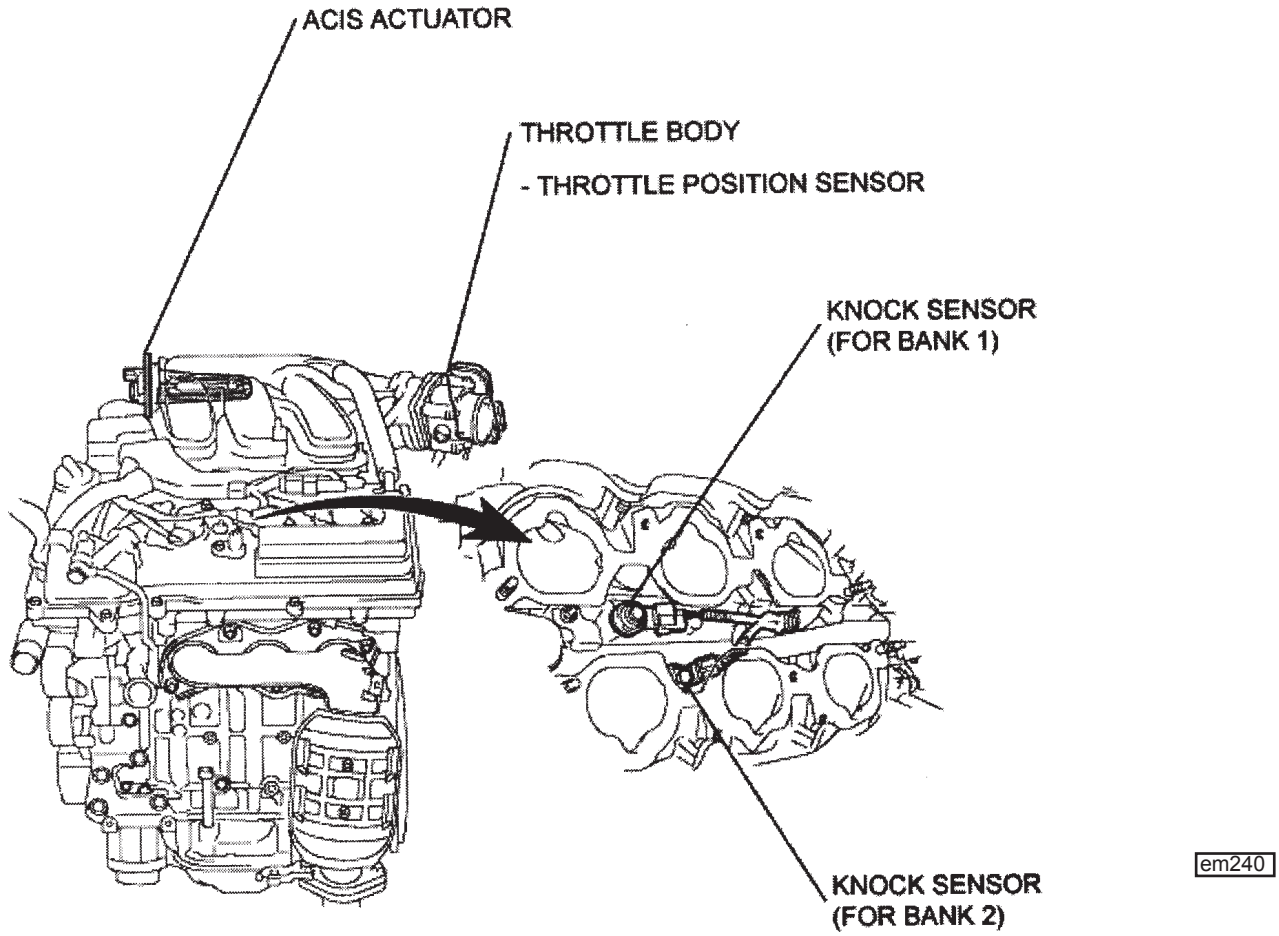



EMR.4 - DIAGNOSTIC GUIDE

**Camshaft Timing Control (VVT)**

- P0011 Camshaft Position – Inlet Timing Over-Advanced or System Performance (Bank 1)
- P0012 Camshaft Position – Inlet Timing Over-Retarded (Bank 1)
- P0014 Camshaft Position – Exhaust Timing Over-Advanced or System Performance (Bank 1)
- P0015 Camshaft Position – Exhaust Timing Over Retarded (Bank 1)
- P0021 Camshaft Position – Inlet Timing Over-Advanced or System Performance (Bank 2)
- P0022 Camshaft Position – Inlet Timing Over-Retarded (Bank 2)
- P0024 Camshaft Position – Exhaust Timing Over-Advanced or System Performance (Bank 2)
- P0025 Camshaft Position – Exhaust Timing Over-Retarded (Bank 2)

**Description**

The Variable Valve Timing system (VVT) on the intake camshafts and the exhaust camshafts can vary the timing by approximately 35°. The camshaft relative position is varied by a system of vanes mounted on the drive end of the camshaft. Each VVT oil control valve modulates a spool valve position in accordance with the drive signal duty cycle, this in turns controls the oil pressure applied to the vanes. A 50% duty cycle applied to the valve will hold the valve current timing by preventing oil flow from the VVT controller housing, a duty cycle less than 50% will retard the valve timing, a duty cycle greater then 50% will advance the valve timing. The ECM regulates this duty cycle based on the feedback signal from the respective camshaft position sensor to optimise the camshaft timing.

**Component connections**

Sensor Connector	Description	ECU Pin	ECU Connector
1	Battery Voltage	-	-
2	VVT Control Valve Inlet (Bank 1)	B2	48 Way (Centre)
1	Battery Voltage	-	-
2	VVT Control Valve Exhaust (Bank 1)	A2	48 Way (Centre)
1	Battery Voltage	-	-
2	VVT Control Valve Inlet (Bank 2)	A3	48 Way (Centre)
1	Battery Voltage	-	-
2	VVT Control Valve Exhaust (Bank 2)	A4	48 Way (Centre)

*Monitor:*

- Continuous

*Enable Criteria:*

- Engine running > 30 secs
- Coolant temperature > 60°C (140°F)

*Disable Criteria:*

- P0116, P0117, P0118 – Coolant temperature fault codes

*Malfunction Criteria:*

- VVT error > 5 degrees for time > 2.5 secs

*Potential failure modes:*

- Static valve timing is incorrect
- VVT camshaft actuator failure
- VVT control valve stuck open / closed
- VVT control valve filter

*Diagnostic Mask:*

- The MIL will be illuminated if the faults are present for 2 consecutive trips

**Crankshaft Position–Camshaft Position Correlation Error**

- P0016 Crankshaft position – camshaft position correlation – bank 1 sensor A (Inlet)  
P0017 Crankshaft position – camshaft position correlation – bank 1 sensor B (Exhaust)  
P0018 Crankshaft position – camshaft position correlation – bank 2 sensor A (Inlet)  
P0019 Crankshaft position – camshaft position correlation – bank 2 sensor B (Exhaust)

*Description*

The crankshaft position sensor is used to identify engine position and speed via a pole wheel mounted on the front end of the crankshaft. The camshaft position sensor is used to determine camshaft position from a three vane retractor on the rear end of the inlet and exhaust camshaft. Fault codes P0016, P0017, P0018, P0019 indicate a mechanical timing error such as incorrectly set, or 'jumped' cam timing.

*Monitor:*

- Continuous

*Enable Criteria:*

- Engine running (from cranking up to 4 seconds)

*Disable Criteria:*

- None

*Malfunction Criteria:*

- Camshaft out of phase with crankshaft > 16 degrees

*Potential failure modes:*

- Static valve timing is incorrect
- VVT camshaft actuator failure
- VVT control valve stuck open / closed
- VVT control valve filter

*Diagnostic Mask:*

- The MIL will be illuminated if the faults are present for 2 consecutive trips



### Camshaft Timing Control (VVT)

- P0076 Intake Valve Control Solenoid Circuit Low (Bank1)
- P0077 Intake Valve Control Solenoid Circuit High (Bank1)
- P0079 Exhaust Valve Control Solenoid Circuit Low (Bank1)
- P0080 Exhaust Valve Control Solenoid Circuit High (Bank1)
- P0082 Intake Valve Control Solenoid Circuit Low (Bank2)
- P0083 Intake Valve Control Solenoid Circuit High (Bank2)
- P0085 Exhaust Valve Control Solenoid Circuit Low (Bank2)
- P0086 Exhaust Valve Control Solenoid Circuit High (Bank2)

#### *Monitor:*

- Continuous

#### *Enable Criteria:*

- Engine running

#### *Disable Criteria:*

- None

#### *Potential failure modes:*

- P0076, P0079, P0082, P0085 - VVT control valve open circuit or short to ground
- P0077, P0080, P0083, P0086 - VVT control valve circuit short to battery voltage
- ECU output circuit failure
- VVT control valve

#### *Diagnostic Mask:*

- The MIL will be illuminated if the faults are present for 2 consecutive trips



**-Intake Air Flow**

- P0101 Mass or Volume Air Flow Circuit Range/Performance
- P0102 Mass or Volume Air Flow Circuit Low Input
- P0103 Mass or Volume Air Flow Circuit High Input

*Description*

The Mass Air Flow (MAF) sensor is incorporated into the airbox, and measures both intake air flow rate and Intake Air Temperature (IAT). The MAF sensor uses a hot wire exposed to the airflow, which is maintained at a constant temperature by a constant current flow. This is achieved within the sensor unit by varying the voltage applied to the hot wire. This voltage is the output signal from the MAF sensor.

*Sensor connections*

Sensor Connector	Description	ECU Pin	ECU Connector
1	IAT Signal	J3	48 Way (Centre)
2	IAT Ground	E3	48 Way (Centre)
3	Battery Voltage	-	-
4	MAF Ground	J4	48 Way (Centre)
5	MAF Signal	G1	48 Way (Centre)

*Sensor characteristics*

0 – 330 g/sec

Typical values: 1.5 – 5.0 g/sec (idle), 5.0 – 15.0 g/sec (2500rpm elevated idle no load)

**P0101**

*Monitor:*

- Continuous.

*Enable Criteria:*

- Engine running
- Engine speed >1500rpm
- Engine speed < 3510rpm
- Fuel Learns enabled

*Disable Criteria:*

- P0122, P0123, P0222, P0223 – Throttle/Pedal position fault codes

*Malfunction Criteria:*

- Measured MAF is compared to a predicted MAF based on current engine conditions.
- Error > 40% for time > 1.5 secs

*Potential failure modes:*

- MAF meter
- Air induction system
- Air intake hose connections

*Diagnostic Mask:*

- The MIL will be illuminated if the faults are present for 2 consecutive trips

**P0102**

*Monitor:*

- Continuous.

*Enable Criteria:*

- Engine running



*Disable Criteria:*

- None

*Malfunction Criteria:*

- Voltage at ECU < 0.52V for time > 1.5 secs

*Potential failure modes:*

- MAF sensor circuit open
- MAF sensor circuit short to ground

*Diagnostic Mask:*

- The MIL will be illuminated if the faults are present for 2 consecutive trips

**P0103**

*Monitor:*

- Continuous.

*Enable Criteria:*

- Engine running

*Disable Criteria:*

- None

*Malfunction Criteria:*

- Voltage at ECU > 4.86V for time > 1.5 secs

*Potential failure modes:*

- MAF sensor circuit short to ECU supply voltage

*Diagnostic Mask:*

- The MIL will be illuminated if the faults are present for 2 consecutive trips



## Barometric Pressure

- P0106 Manifold Absolute Pressure/Barometric Pressure Circuit Range/Performance
- P0107 Manifold Absolute Pressure/Barometric Pressure Circuit Low Input
- P0108 Manifold Absolute Pressure/Barometric Pressure Circuit High Input

### *Description*

The barometric pressure sensor is located internally within the ECU, and measures atmospheric pressure. This parameter is required to compensate the mass air flow when the vehicle is operated at higher altitudes.

### **P0106**

### **P0107, P0108**

#### *Monitor:*

- Continuous

#### *Enable Criteria:*

- Engine running

#### *Disable Criteria:*

- None

#### *Malfunction Criteria:*

- P0107: Voltage at ECU < 1.08V for time > 1.5 secs
- P0108: Voltage at ECU > 4.98V for time > 1.5 secs

#### *Potential failure modes:*

- Sensor failure

#### *Diagnostic Mask:*

- The MIL will be illuminated if the faults are present for 2 consecutive trips



**Intake Air Temperature**

P0111 Intake Air Temperature Sensor 1 Circuit Range/Performance

P0112 Intake Air Temperature Sensor 1 Circuit Low

P0113 Intake Air Temperature Sensor 1 Circuit High

*Description*

The combined sensor which measures both Mass Air Flow (MAF) and Intake Air Temperature (IAT) is incorporated into the air box. The IAT sensor is a thermistor device which changes resistance with temperature. As air intake temperature decreases the thermistor resistance value increases, and conversely as air temperature increases so the thermistor resistance value decreases.

*Sensor connections*

Sensor Connector	Description	ECU Pin	ECU Connector
1	IAT Signal	J3	48 Way (Centre)
2	IAT Ground	E3	48 Way (Centre)
3	Battery Voltage	-	-
4	MAF Ground	J4	48 Way (Centre)
5	MAF Signal	G1	48 Way (Centre)

*Sensor characteristics*

IAT -20°C (-4°F) 13.6 – 18.4 kΩ

IAT 20°C (68°F) 2.21 – 2.69 kΩ

IAT 60°C (140°F) 0.50 – 0.67 kΩ

**P0111**



**P0112**

*Monitor:*

- Continuous

*Disable Criteria:*

- None

*Enable Criteria:*

- Engine running

*Malfunction Criteria:*

- Inlet air temperature > 119°C (246°F) for time > 1.5 secs

*Potential failure modes:*

- Signal short circuit
- Sensor failure

*Diagnostic Mask:*

- The MIL will be illuminated if these faults are present for 2 consecutive trips.

**P0113**

*Monitor:*

- Continuous

*Disable Criteria:*

- None

*Enable Criteria:*

- Engine running

*Malfunction Criteria:*

- Inlet air temperature < -40°C (-104°F) for time > 1.5 secs

*Potential failure modes:*

- Signal open circuit
- Sensor failure

*Diagnostic Mask:*

- The MIL will be illuminated if these faults are present for 2 consecutive trips.



## Engine Coolant Temperature

- P0116 Engine Coolant Temperature Circuit Range/Performance
- P0117 Engine Coolant Temperature Circuit Low
- P0118 Engine Coolant Temperature Circuit High

### *Description*

The engine coolant temperature sensor is a thermistor device which changes resistance with temperature. As coolant temperature decreases the thermistor resistance value increases, and conversely as coolant temperature increases so the thermistor resistance value decreases.

### *Sensor connections*

Sensor Connector	Description	ECU Pin	ECU Connector
1	Ground	C3	48 Way (Centre)
2	Signal	G2	48 Way (Centre)

### *Sensor characteristics*

-20°C (-4°F)	= 13.84 – 16.33 KΩ
20°C (68°F)	= 2.31 – 2.58 KΩ
80°C (176°F)	= 0.310 – 0.326 KΩ
110°C (230°F)	= 0.1399 – 0.1435 KΩ

### **P0116**

#### *Monitor:*

- Continuous

#### *Disable Criteria:*

- None

#### *Enable Criteria 1:*

- Engine running > 1000 seconds

#### *Malfunction Criteria 1:*

- Engine coolant temperature < 40°C (104°F)

#### *Enable Criteria 2:*

- Engine running

#### *Malfunction Criteria 2:*

- Engine coolant temperature erratic by more than 30°C (54°F)

#### *Potential failure modes:*

- Sensor wiring
- Sensor failure
- Thermostat failure

#### *Diagnostic Mask:*

- The MIL will be illuminated if these faults are present for 2 consecutive trips.

### **P0117**

#### *Monitor:*

- Continuous

#### *Disable Criteria:*

- None



*Enable Criteria:*

- Engine running

*Malfunction Criteria:*

- Coolant temperature > 119°C (246°F) for time > 1.5 secs

*Potential failure modes:*

- Signal short circuit
- Sensor failure
- Thermostat failure
- Cooling system problem

*Diagnostic Mask:*

- The MIL will be illuminated if these faults are present for 2 consecutive trips.

**P0118**

*Monitor:*

- Continuous

*Disable Criteria:*

- None

*Enable Criteria:*

- Engine running

*Malfunction Criteria:*

- Coolant temperature > -38°C (-36°F) for time > 1.5 secs

*Potential failure modes:*

- Signal open circuit
- Sensor failure

*Diagnostic Mask:*

- The MIL will be illuminated if these faults are present for 2 consecutive trips.



## Throttle Position

- P0122 Throttle Position Sensor 'A' Circuit Low
- P0123 Throttle Position Sensor 'A' Circuit High
- P0222 Throttle Position Sensor 'B' Circuit Low
- P0223 Throttle Position Sensor 'B' Circuit High

### *Description*

The throttle position sensor (TPS) is mounted on the throttle body, and detects the opening angle of the throttle valve. The TPS has 2 sensor circuits, each of which transmits a signal, VTA1 and VTA2. VTA1 is used to detect the throttle valve angle and VTA2 is used to detect malfunctions in VTA1. The sensor signal voltages vary between 0 V and 5 V in proportion to the throttle valve opening angle, and are transmitted to the VTA terminals of the ECU.

### *Sensor connections*

Sensor Connector	Description	ECU Pin	ECU Connector
1	ETB -ve	M1	48 Way (Centre)
2	ETB +ve	L2	48 Way (Centre)
3	Ground	C4	48 Way (Centre)
4	TPS 1B Signal	F3	48 Way (Centre)
5	TPS 1A/B V Ref	E4	48 Way (Centre)
6	TPS 1A Signal	F2	48 Way (Centre)

### *Sensor characteristics*

0% = 0.595 V  $\pm$  5%

100% = 4.148 V  $\pm$  5%

### **P0122**

#### *Monitor:*

- Continuous.

#### *Enable Criteria:*

- None

#### *Disable Criteria:*

- None

#### *Malfunction Criteria:*

- Signal voltage < 0.635V

#### *Potential failure modes:*

- Signal short circuit
- Reference voltage open circuit
- Reference voltage short to ground
- Sensor failure

#### *Diagnostic Mask:*

- The MIL will be illuminated if fault is present.

### **P0123**

#### *Monitor:*

- Continuous.

#### *Enable Criteria:*

- None



*Disable Criteria:*

- None

*Malfunction Criteria:*

- Signal voltage > 4.765V

*Potential failure modes:*

- Signal open circuit
- Reference voltage open circuit
- Reference voltage short to ground
- Sensor failure

*Diagnostic Mask:*

- The MIL will be illuminated if fault is present.

**P0222**

*Monitor:*

- Continuous.

*Enable Criteria:*

- None

*Disable Criteria:*

- None

*Malfunction Criteria:*

- Signal voltage < 2.146V

*Potential failure modes:*

- Signal short circuit
- Reference voltage open circuit
- Reference voltage short to ground
- Sensor failure

*Diagnostic Mask:*

- The MIL will be illuminated if fault is present.

Notes: A maximum throttle opening of 15% may be imposed due to this single code. In the case of multiple codes, a mechanically sprung 7% opening may be applied.

**P0223**

*Monitor:*

- Continuous.

*Enable Criteria:*

- None

*Disable Criteria:*

- None

*Malfunction Criteria:*

- Signal voltage > 4.985V



*Potential failure modes:*

- Signal open circuit
- Reference voltage open circuit
- Reference voltage short to ground
- Sensor failure

*Diagnostic Mask:*

- The MIL will be illuminated if fault is present.

Notes: A maximum throttle opening of 15% may be imposed due to this single code. In the case of multiple codes, a mechanically sprung 7% opening may be applied.



**Coolant Thermostat (USA only)**

P0128 Coolant Thermostat (Coolant Temperature Below Thermostat Regulating Temperature)





**O2 Sensor (Pre Catalyst)**

- P0131 O2 Sensor 1 Circuit Low Voltage (Bank 1)
- P0132 O2 Sensor 1 Circuit High Voltage (Bank 1)
- P0133 O2 Sensor 1 Circuit Slow Response (Bank 1)
- P0134 O2 Sensor 1 Circuit No Activity Detected (Bank 1)
- P0135 O2 Sensor 1 Heater Circuit (Bank 1)
- P0151 O2 Sensor 1 Circuit Low Voltage (Bank 2)
- P0152 O2 Sensor 1 Circuit High Voltage (Bank 2)
- P0153 O2 Sensor 1 Circuit Slow Response (Bank 2)
- P0154 O2 Sensor 1 Circuit No Activity Detected (Bank 2)
- P0155 O2 Sensor 1 Heater Circuit (Bank 2)

*Description*

The oxygen sensors separately monitor the oxygen content in the exhaust gases of each bank of the engine. Each sensor is electrically heated to improve response after start.

The sensor consists of a zirconia electrode between two platinum plates. When zirconia comes into contact with oxygen, it becomes an electrical conductor. The exhaust gases pass through louvers in the sensor. One plate is in contact with the outside air and the other plate is in contact with the exhaust gases. The platinum plate in contact with the air is electrically negative due to the oxygen in the atmosphere and the plate in contact with the exhaust gases is electrically positive. This will cause a difference in electrical potential to develop between the two plates. Thus the voltage across the platinum plates ranges approximately from 100 millivolts to 900 millivolts, depending on the oxygen content of the exhaust gases. Thus when the air/fuel mixture is rich, the oxygen sensor output will be high. If the air/fuel mixture is lean, the oxygen sensor output will be low.

*Sensor connections*

Sensor Connector	Description	ECU Pin	ECU Connector
1 Bank 1	Signal	G3	48 Way (Centre)
2 Bank 1	Ground	J2	48 Way (Centre)
3 Bank 1	Heater	H3	48 Way (Centre)
4 Bank 1	Battery Voltage	-	-
1 Bank 2	Signal	G4	48 Way (Centre)
2 Bank 2	Ground	J2	48 Way (Centre)
3 Bank 2	Heater	H4	48 Way (Centre)
4 Bank 2	Battery Voltage	-	-

*Sensor characteristics*

Normal operating range is 0 – 1000mV

**P0131 (Bank1) or P0151 (Bank2)**

*Monitor:*

- Continuous.

*Disable Criteria:*

- DFCO (Deceleration Fuel Cut Off)
- AE DE (Acceleration Enrichment Deceleration Enleanment)
- Misfire

*Enable Criteria:*

- Engine running

*Failure Criteria:*

- Sensor voltage < 15mV for more than 1.5 seconds consecutively for a specified number of times.



*Potential failure modes:*

- Low fuel pressure (Lean mixture)
- Malfunctioning sensor
- External water on sensor
- Sensor wire shorted to ground

*Diagnostic Mask:*

- The MIL will be illuminated if these faults are present for 2 consecutive trips.

**P0132 (Bank1) or P0152 (Bank2)**

*Monitor:*

- Continuous.

*Disable Criteria:*

- None

*Enable Criteria:*

- Engine running

*Malfunction Criteria:*

- Sensor voltage > 1200V for more than 1.5 seconds consecutively for a specified number of times.

*Potential failure modes:*

- High fuel pressure (Rich mixture)
- Leaking or shorted injector
- Purge valve fault
- Oxygen sensor contamination
- Engine oil contamination
- Sensor wire shorted to heater voltage

*Diagnostic Mask:*

- The MIL will be illuminated if these faults are present for 2 consecutive trips.

**P0133 (Bank1) or P0153 (Bank2)**

*Monitor:*

- Continuous.

*Disable Criteria:*

- P0116, P0117, P0118 – Coolant temperature sensor faults
- P0101, P0102, P0103 – MAF sensor faults
- P0335, P0500 – Crank or vehicle speed faults
- P0131, P0132, P0134, P0135 – Pre catalyst oxygen sensor faults for Bank1 checks
- P0151, P0152, P0154, P0155 – Pre catalyst oxygen sensor faults for Bank2 checks

*Enable Criteria:*

- Vehicle speed between 0 – 255 km/h (158.5 mph)
- MAF per stroke between 15 – 48 mg
- Engine speed between 1285 – 1818rpm
- Engine run time > 200 seconds
- Coolant temperature > 60°C (140°F)
- Closed loop fuelling enabled

*Monitor:*

- Monitored until the required amount of switches (30) in both directions has been achieved or 130 seconds has elapsed.



### *Malfunction Criteria:*

- Set when the sensor fails to switch from a Lean to a Rich condition or switch from a Rich to a Lean condition in a sufficiently timely manner. A selection of switches is used to determine the average times.  
"highlighted section removed"

### *Potential failure modes:*

- Sensor connector and wiring should be checked for corrosion and loose connections
- Sensor contaminated, possibly from fuel, improper use of RTV, engine oil or coolant

### *Diagnostic Mask:*

- The MIL will be illuminated if these faults are present for 2 consecutive trips.

### **P0134 (Bank1) or P0154 (Bank2)**

#### *Monitor:*

- Until either passed or failed.

#### *Enable Criteria:*

- Engine run time > 30 seconds
- Engine is not at idle
- Engine is in closed loop fuel control
- O2 sensor ready

### *Malfunction Criteria:*

- Set when the sensor fails to switch above 673mV and below 400mV within a 60 second period.

### *Potential failure modes:*

- Sensor connector and wiring should be checked for corrosion and loose connections.
- Gas leak in exhaust system

### *Diagnostic Mask:*

- The MIL will be illuminated if these faults are present for 2 consecutive trips.

### **P0135, P0155**

#### *Monitor:*

- Continuous

#### *Enable Criteria:*

- Engine run time > 20 seconds

### *Malfunction Criteria:*

- Set when the heater output is greater than 1900mA or less than 250mA for 1.5 seconds, for 40 consecutive checks.

### *Potential failure modes:*

- Sensor connector and wiring should be checked for corrosion and loose connections.

### *Diagnostic Mask:*

- The MIL will be illuminated if these faults are present for 2 consecutive trips.



**O2 Sensor (Post Catalyst)**

- P0137 O2 Sensor Circuit Low Voltage (Bank 1)
- P0138 O2 Sensor Circuit High Voltage (Bank 1)
- P0139 O2 Sensor Circuit Slow Response (Bank 1)
- P0140 O2 Sensor Circuit No Activity Detected (Bank 1)
- P0141 O2 Sensor Heater Circuit (Bank 1)
- P0157 O2 Sensor Circuit Low Voltage (Bank 2)
- P0158 O2 Sensor Circuit High Voltage (Bank 2)
- P0159 O2 Sensor Circuit Slow Response (Bank 2)
- P0160 O2 Sensor Circuit No Activity Detected (Bank 2)
- P0161 O2 Sensor Heater Circuit (Bank 2)

*Description*

The oxygen sensors separately monitor the oxygen content in the exhaust gases of each bank of the engine. Each sensor is electrically heated to improve response from start.

The sensor consists of a zirconia electrode between two platinum plates. When zirconia comes into contact with oxygen, it becomes an electrical conductor. The exhaust gases pass through louvers in the sensor. One plate is in contact with the outside air and the other plate is in contact with the exhaust gases. The platinum plate in contact with the air is electrically negative due to the oxygen in the atmosphere and the plate in contact with the exhaust gases is electrically positive. This will cause a difference in electrical potential to develop between the two plates. Thus the voltage across the platinum plates ranges approximately from 100 millivolts to 900 millivolts, depending on the oxygen content of the exhaust gases. Thus when the air/fuel mixture is rich, the oxygen sensor output will be high. If the air/fuel mixture is lean, the oxygen sensor output will be low. The post catalyst oxygen sensor performance is a good indicator of catalyst efficiency.

*Sensor connections*

Sensor Connector	Description	ECU Pin	ECU Connector
1 Bank 1	Signal	H1	48 Way (Centre)
2 Bank 1	Ground	K4	48 Way (Centre)
3 Bank 1	Heater	K1	48 Way (Centre)
4 Bank 1	Battery Voltage	-	-
1 Bank 2	Signal	H2	48 Way (Centre)
2 Bank 2	Ground	K4	48 Way (Centre)
3 Bank 2	Heater	K2	48 Way (Centre)
4 Bank 2	Battery Voltage	-	-

*Sensor characteristics*

Normal operating range is 0 – 1000mV

**P0137, P0157**

*Monitor:*

- Continuous

*Enable Criteria:*

- None

*Disable Criteria:*

- DFCO (Deceleration Fuel Cut Off)
- AE DE (Acceleration Enrichment or Deceleration Enleanment)
- Misfire

*Malfunction Criteria:*

- Set when the sensor operates below 15mV for more than 1.5 seconds consecutively for a specified number of times.



*Potential failure modes:*

- Check and rectify any pre catalyst sensor fault code, as they may be causing the fault code to be set
- Sensor wire shorted to ground
- Catalyst

*Diagnostic Mask:*

- The MIL will be illuminated if these faults are present for 2 consecutive trips.

**P0138, P0158**

*Monitor:*

- Continuous

*Enable Criteria:*

- Engine running

*Disable Criteria:*

- None

*Malfunction Criteria:*

- Set when the sensor operates above 1200mV for more than 1.5 seconds consecutively for a specified number of times.

*Potential failure modes:*

- Check and rectify any front sensor fault code, as they may be causing the fault code to be set
- Catalyst

*Diagnostic Mask:*

- The MIL will be illuminated if these faults are present for 2 consecutive trips.

**P0139, P0159**



**P0140, P0160**

*Monitor:*

- Continuous

*Enable Criteria:*

- Engine run time > 30 seconds
- Engine is not at idle
- Engine is in closed loop fuel control
- Oxygen sensors ready

*Disable Criteria:*

- None

*Malfunction Criteria:*

- Set when the sensor fails to switch above 673mV and below 400mV within 60 seconds.

*Potential failure modes:*

- Check and rectify any front sensor fault code, as they may be causing the fault code to be set
- Sensor connector and wiring should be checked for corrosion and loose connections
- Catalyst
- Gas leak in exhaust system

*Diagnostic Mask:*

- The MIL will be illuminated if these faults are present for 2 consecutive trips.

**P0141, P0161**

*Monitor:*

- Continuous

*Enable Criteria:*

- Engine run time > 20 seconds

*Disable Criteria:*

- None

*Malfunction Criteria:*

- Set when the heater output is greater than 1900mA or less than 250mA for 1.5 seconds, for 40 consecutive checks.

*Potential failure modes:*

- Sensor connector and wiring should be checked for corrosion and loose connections

*Diagnostic Mask:*

- The MIL will be illuminated if a fault is present for two consecutive trips.

**Fuel Control System Too Lean Or Rich**

- P0171 System Too Lean (Bank 1)
- P0172 System Too Rich (Bank 1)
- P0174 System Too Lean (Bank 2)
- P0175 System Too Rich (Bank 2)

*Description*

The oxygen sensor sends a signal to the ECU corresponding to the exhaust gas oxygen content enabling the ECU to maintain a 14.7:1 air/fuel ratio under normal driving conditions. The ECU can make fuel corrections of  $\pm 30\%$  to the calculated fuel demand. This value is then learned by the ECU over time. If the ECU determines a rich condition exists (oxygen sensor above 450mV), it will decrease the calculated fuel demand to maintain a 14.7:1 ratio. If the ECU determines a lean condition exists (oxygen sensor below 450mV), it will increase the calculated fuel demand to maintain a 14.7:1 ratio.

*Monitor:*

- Continuous

*Enable Criteria:*

- Fuel Trim condition enabled
- Closed loop fuelling enabled
- MAF < 28 g/sec
- Altitude < 8000 ft (2438 m), Baro > 756 mbar

*Disable Criteria P0171 & P0172:*

- P0106, P0107, P0108 – Baro sensor faults
- P0131, P0135 – Oxygen sensor faults
- P0300, P0301, P0302, P0303 – Misfire faults
- P0111, P0112, P0113 – Intake air temperature faults

*Disable Criteria P0174 & P0175:*

- P0106, P0107, P0108 – Baro sensor faults
- P0151, P0155 – Oxygen sensor faults
- P0300, P0304, P0305, P0306 – Misfire faults
- P0111, P0112, P0113 – Intake air temperature faults

*Malfunction Criteria P0171 & P0174:*

- These codes will set when the relevant engine bank learned fuel correction has been increased to its maximum limit of 25% and the system still cannot maintain an air/fuel ratio of 14.7:1 under normal driving conditions.
- These codes will also be set if the relevant bank fuel learn injector dead time is greater than 450 micro seconds.

*Potential failure modes:*

- Fuel Pressure too low (restriction in fuel line)
- Air leak in induction system
- Water in fuel
- Exhaust leak / crack before front oxygen sensor
- Injector fault
- Sensor connector and wiring for signs of corrosion or loose connections
- MAF fault
- Vehicle has previously run out of fuel

*Diagnostic Mask:*

- The MIL will be illuminated if fault is present for two consecutive trips.



### *Malfunction Criteria P0172, P0175:*

- These codes will be set when the relevant bank learned fuel correction has been decreased to its minimum limit of -25% and the system still cannot maintain an air/fuel ratio of 14.7:1 under normal driving conditions.
- These codes will also be set if the relevant bank fuel learn injector dead time is less than -450 micro seconds.

### *Potential failure modes:*

- Fuel pressure too high
- Leaking fuel injector
- Restriction in the exhaust system or air intake / filter
- Erratic throttle position sensor
- MAF fault
- O2 sensor fault
- Ignition fault

### *Diagnostic Mask:*

- The MIL will be illuminated if a fault is present for two consecutive trips.





## Fuel Injection System

- P0261 Injector Circuit low voltage – Cylinder 1
- P0262 Injector Circuit high voltage – Cylinder 1
- P0264 Injector Circuit low voltage – Cylinder 2
- P0265 Injector Circuit high voltage – Cylinder 2
- P0267 Injector Circuit low voltage – Cylinder 3
- P0268 Injector Circuit high voltage – Cylinder 3
- P0270 Injector Circuit low voltage – Cylinder 4
- P0271 Injector Circuit high voltage – Cylinder 4
- P0273 Injector Circuit low voltage – Cylinder 5
- P0274 Injector Circuit high voltage – Cylinder 5
- P0276 Injector Circuit low voltage – Cylinder 6
- P0277 Injector Circuit high voltage – Cylinder 6

### *Description*

The ECU has six injector driver circuits, each of which controls an injector. When the engine is running the ECU continuously monitors the injector circuit feedback signals. The monitored feedback signal should be low voltage when the injector is ON and high voltage when the injector is OFF.

### *Component connections*

<u>Injector</u>	<u>ECU Pin</u>	<u>ECU Connector</u>
1	H4	32 Way (Left)
2	H3	32 Way (Left)
3	H2	32 Way (Left)
4	H1	32 Way (Left)
5	G4	32 Way (Left)
6	G3	32 Way (Left)

### *Monitor:*

- Continuous

### *Enable Criteria:*

- Engine running

### *Potential failure modes:*

- Sensor connector or wiring corroded or loose connections

### *Diagnostic Mask:*

- The MIL will be illuminated if these faults are present for 2 consecutive trips.

### *Limp home:*

- Limit maximum engine speed to 4000rpm
- Return the fuel system of the affected bank to open loop fuel control

### *Notes:*

If an injector goes short circuit it is likely that the ECU injector driver will be damaged.



## Misfire

- P0300 Random/Multiple Cylinder Misfire Detected
- P0301 Cylinder 1 Misfire Detected
- P0302 Cylinder 2 Misfire Detected
- P0303 Cylinder 3 Misfire Detected
- P0304 Cylinder 4 Misfire Detected
- P0305 Cylinder 5 Misfire Detected
- P0306 Cylinder 6 Misfire Detected

### Description

A misfiring cylinder can be detected by analysing crank speed variation. As a result of a combustion event there will be a net acceleration of the crankshaft. Subsequent to a misfire event the engine will decelerate over the period following the missed cylinder event.

Speed changes can be characterised by observing changes in the time period for a fixed angle of rotation after firing events. A significant change in this period, assessed by comparison to previous periods, may be attributed to misfire on a known cylinder.

### Component connections

Connector	Description	ECU Pin						ECU Connector
1	Supply Voltage	Coil 1	Coil 2	Coil 3	Coil 4	Coil 5	Coil 6	
2	Ignition Coil Feedback	D2	D2	D2	D2	D2	D2	32 Way (Left)
3	Coil Output (Logic)	F4	F3	F2	F1	E4	E3	32 Way (Left)
4	Ground							

### Malfunction Criteria

The operation of all the misfire codes is the same, the last digit relates to the misfire involved i.e. a code P0303 indicates there is a problem with cylinder number 3.

P0300 indicates the misfire is random and not linked to one particular cylinder.

### Monitor:

- Continuous

### Enable Criteria:

- Battery voltage between 10 – 16 V
- Coolant temperature between -10 – 120°C (14 – 248°F)
- Engine speed between 480 – 8010rpm
- Engine speed transient > 15rpm
- Altitude < 8000 ft (2438 m) / Baro > 756mbar
- Fuel level > 5 litres (1.3 US gallons)
- Engine load greater than 14 – 25% depending on engine speed

### Disable Criteria:

- DFCO enabled (Deceleration Fuel Cut Off)
- Rough road
- MAF faults

### Malfunction Criteria:

- Individual cylinder misfire in excess of 10% of total engine misfire
- P300 set when more than one cylinder misfiring or when CAM error MIL requested

### Limp home (depends on severity and number of cylinders affected):

- Throttle limited and engine continues to run on all cylinders
- Fuel system set to open loop control
- Affected bank shut down and engine speed limited to 4000 rpm



*Potential failure modes:*

- Injectors or related codes
- VVT system (clearance or timing) or related codes
- MAF meter or related codes
- Connectors and wiring for signs of corrosion or loose connections
- Spark plug / coil / cylinder compression
- PCV system / hoses
- Fuel pressure
- Coolant temperature sensor
- Vacuum hoses
- ECU

*Diagnostic Mask:*

- The MIL will be illuminated if a fault is present for two consecutive trips.

**Knock Control System**

- P0327 Knock Sensor Circuit Low (Bank 1)
- P0328 Knock Sensor Circuit High (Bank 1)
- P0332 Knock Sensor Circuit Low (Bank 2)
- P0333 Knock Sensor Circuit High (Bank 2)

*Description*

The knock sensor contains a piezoelectric element which generates a voltage when it becomes deformed. The piezoelectric element sends continuously sends a signal to the ECU, when the cylinder block vibrates due to engine knocking this signal increases. The ECU is able to identify each cylinder. If knock is detected then the ECU will retard the ignition of the relevant cylinder to suppress it.

The knock control sensor cannot differentiate between spark knock and other similar sounding noises.

*Sensor connections*

Sensor Connector	Description	ECU Pin	ECU Connector
1 Bank 1	Sensor input	D1	48 Way (Centre)
2 Bank 1	Ground	C1	48 Way (Centre)
3 Bank 2	Sensor input	D2	48 Way (Centre)
4 Bank 2	Ground	C2	48 Way (Centre)

*Monitor:*

- Continuous

*Enable Criteria:*

- Engine running

*Malfunction Criteria:*

- P0327 – This code is set when the bank 1 knock sensor signal is < 0.586 V
- P0328 – This code is set when the bank 1 knock sensor signal is > 2.932 V
- P0332 – This code is set when the bank 2 knock sensor signal is < 0.586 V
- P0333 – This code is set when the bank 2 knock sensor signal is > 2.932 V

*Potential failure modes:*

- Abnormal engine noise, i.e. damaged engine or exhaust system contacting vehicle
- Knock sensor fixing too tight
- Sensor connector / wiring corroded or loose connections
- ECU

*Diagnostic Mask:*

- The MIL will be illuminated if a fault is present for two consecutive trips.



## Engine Speed / Position Sensors

P0335 Crankshaft Position Sensor "A" Circuit Range/Performance

### *Description*

Engine speed is calculated by measuring the time between the 'teeth' of the crankshaft sensor trigger disc. The disc has 34 'teeth' and 2 missing 'teeth', spaced at 10 degree intervals around the disc. The 2 missing 'teeth' are positioned at 225 degrees before cylinder No.1 and 4 TDC. The crankshaft sensor signal is also used to determine misfires events.

### *Sensor connections*

Sensor Connector	Description	ECU Pin	ECU Connector
1	Sensor input	A4	32 Way (Left)
2	Ground	B2	32 Way (Left)

### *Monitor:*

- Continuous

### *Enable Criteria:*

- Engine running

### *Disable Criteria:*

- None

### *Malfunction Criteria:*

- 15 crank errors in succession. This can occur due to no crank signal occurring whilst the cams continue to count or if there is a measured consecutive crank error.

### *Potential failure modes:*

- Sensor signal open circuit or short to ground
- Sensor ground open circuit
- Sensor failure
- Crankshaft sensor plate
- ECU

### *Diagnostic Mask:*

- The MIL will be illuminated if this fault is present for two consecutive trips.

### *Notes:*

If a sensor or sensor circuit failure occurs, the engine will not fire or start.



## Engine Speed / Position Sensors

- P0341 Camshaft Position Sensor "A" Circuit (Bank 1)
- P0346 Camshaft Position Sensor "A" Circuit (Bank 2)
- P0366 Camshaft Position Sensor "B" Circuit (Bank 2)
- P0391 Camshaft Position Sensor "B" Circuit (Bank 2)

### *Description*

The camshaft position input to the ECU is used to determine engine phase, enable sequential fuel injection control and to determine camshaft position for VVT control. The inlet camshaft has three 'teeth' spaced 90° apart, which are detected by the electromagnetic sensor. The valve timing setting is measured in the ECU by measuring time from a (fixed position) crankshaft tooth to a (variable position) camshaft tooth. As the engine speed and the position is known from the crankshaft sensor signal, the camshaft position can be calculated.

### *Sensor connections*

Sensor Connector	Description	ECU Pin	ECU Connector
1 Inlet Bank 1	Signal	A3	32 Way (Left)
2 Inlet Bank 1	Ground	B3	32 Way (Left)
3 Supply voltage	5V	D1	32 Way (Left)
1 Exhaust Bank 1	Signal	D4	32 Way (Left)
2 Exhaust Bank 1	Ground	C3	32 Way (Left)
3 Supply voltage	5V	D1	32 Way (Left)
1 Inlet Bank 2	Signal	A2	32 Way (Left)
2 Inlet Bank 2	Ground	C2	32 Way (Left)
3 Supply voltage	5V	D1	32 Way (Left)
1 Exhaust Bank 2	Signal	D3	32 Way (Left)
2 Exhaust Bank 2	Ground	C4	32 Way (Left)
3 Supply voltage	5V	D1	32 Way (Left)

### *Monitor:*

- Continuous

### *Enable Criteria:*

- Engine running
- Engine speed > 600rpm
- Engine runtime > 4 secs

### *Disable Criteria:*

- None

### *Malfunction Criteria:*

- 15 revolutions of crankshaft without receiving camshaft signal

### *Potential failure modes:*

- Sensor signal open circuit or short to ground
- Sensor ground open circuit
- Sensor failure
- Cam failure
- Camshaft position plate
- ECU

### *Diagnostic Mask:*

- The MIL will be illuminated if a fault is present for two consecutive trips.

### *Notes:*

Fault code P0341 will also be generated if the vehicle fails security checks on start up.



**Ignition System**

- P0351 Ignition Coil "A" Primary/Secondary Circuit
- P0352 Ignition Coil "B" Primary/Secondary Circuit
- P0353 Ignition Coil "C" Primary/Secondary Circuit
- P0354 Ignition Coil "D" Primary/Secondary Circuit
- P0355 Ignition Coil "E" Primary/Secondary Circuit
- P0356 Ignition Coil "F" Primary/Secondary Circuit

*Description*

A Direct Ignition System (DIS) is used on the engine. The DIS improves the ignition accuracy, reduces high-voltage loss, and enhances the reliability of the ignition system. The DIS is a 1-cylinder system that ignites one cylinder with one ignition coil. The ECU determines the ignition timing and outputs the ignition signals (IGT) for each cylinder. Based on IGT signals, the power transistors in the igniter cuts off the current to the primary coil, which induces a spark at the spark plug connected to the secondary coil. The igniter will also send an ignition confirmation signal (IGF) as a fail-safe measure to the ECU.

*Component connections*

Connector Pin	Description	ECU Pin						ECU Connector
1	Supply Voltage	Coil 1	Coil 2	Coil 3	Coil 4	Coil 5	Coil 6	
2	Ignition Coil Feedback	D2	D2	D2	D2	D2	D2	32 Way (Left)
3	Coil Output (Logic)	F4	F3	F2	F1	E4	E3	32 Way (Left)
4	Ground							

*Monitor:*

- Continuous

*Enable Criteria:*

- Engine running

*Malfunction Criteria:*

- No IGF signal to ECM while engine is running

*Potential failure modes:*

- Open or short in IGF1 – IGF6 circuits from ignition coil to ECU
- Coil failure
- ECU

*Diagnostic Mask:*

- The MIL will be illuminated if a fault is present for two consecutive trips.



## Catalyst System Efficiency

- P0420 Catalyst System Efficiency Below Threshold (Bank 1)
- P0430 Catalyst System Efficiency Below Threshold (Bank 2)

### *Description*

The ECU compares the waveform of the oxygen sensors located before and after the catalyst to determine whether or not the catalyst has deteriorated. If the catalyst is functioning normally the front oxygen sensor will be switching between rich and lean whilst the rear oxygen sensor should also be switching between rich and lean but more slowly. When both the oxygen sensor waveforms change at a similar rate, it indicates that the catalyst performance has deteriorated. The ECU counts the number of pre and post catalyst oxygen sensor switches and divides one by the other to determine a ratio. If this ratio is too high a fault will be indicated.

### *Sensor connections*

Pre catalyst oxygen sensor

Sensor Connector	Description	ECU Pin	ECU Connector
1 Bank 1	Signal	G3	48 Way (Centre)
2 Bank 1	Ground	J2	48 Way (Centre)
3 Bank 1	Heater Supply	H3	48 Way (Centre)
4 Bank 1	Battery Voltage	-	-
1 Bank 2	Signal	G4	48 Way (Centre)
2 Bank 2	Ground	J2	48 Way (Centre)
3 Bank 2	Heater Supply	H4	48 Way (Centre)
4 Bank 2	Battery Voltage	-	-

Post catalyst oxygen sensor

Sensor Connector	Description	ECU Pin	ECU Connector
1 Bank 1	Signal	H1	48 Way (Centre)
2 Bank 1	Ground	K4	48 Way (Centre)
3 Bank 1	Heater Supply	K1	48 Way (Centre)
4 Bank 1	Battery Voltage	-	-
1 Bank 2	Signal	H2	48 Way (Centre)
2 Bank 2	Ground	K4	48 Way (Centre)
3 Bank 2	Heater Supply	K2	48 Way (Centre)
4 Bank 2	Battery Voltage	-	-

### *Monitor:*

- Continuous

### *Enable Criteria:*

- Closed loop fuel control enabled
- Coolant temperature > 60 °C (140 °F)
- Baro > 756 mbar
- Vehicle speed < 130 km/h (81 mph)
- MAF < 48 g/sec & MAF > 2 g/sec
- Air inlet temp > -10°C (14°F)
- Accumulated Mass Air > 2000-4080 grams depending on coolant temperature





*Disable Criteria:*

- P0101, P0102, P0103
  - P0107, P0108
  - P0116, P0117, P0118
  - P0131, P0132, P0133, P0134, P0135, P0137, P0138, P0139, P0140, P0141 – Oxygen sensor faults B1
  - P0151, P0152, P0153, P0154, P0155, P0157, P0158, P0159, P0160, P0161 – Oxygen sensor faults B2
  - P0171, P0172, P0174, P0175
  - P0300, P0301, P0302, P0303, P0304, P0305, P0306
  - P0500
- MAF faults
  - MAP / Baro Faults
  - Coolant temperature faults
  - Fuelling faults B1 / B2
  - Misfire faults
  - Speed sensor fault

*Malfunction Criteria:*

- Switch ratio between Pre & Post catalytic converter O2 sensors > 0.6

*Potential failure modes:*

- Exhaust system leak
- Oxygen sensor faults
- Oxygen sensor heater failure
- Catalyst failure

*Diagnostic Mask:*

- The MIL will be illuminated if these faults are present for 2 consecutive trips.



**Evaporative Emission Control – Leak Detection System**

- P0441 Evaporative Emission System Incorrect Purge Flow
- P0442 Evaporative Emission System Leak Detected (small leak)
- P0455 Evaporative Emission System Leak Detected (large leak)
- P0456 Evaporative Emission System Leak Detected (very small leak)







## Evaporative Emission Control – Purge, Open / Closed Circuit

- P0444 Evaporative Emission System Purge Control Valve Circuit Open
- P0445 Evaporative Emission System Purge Control Valve Circuit Closed
- P0446 Evaporative Emission System Vent Control Circuit
- P0447 Evaporative Emission System Vent Control Circuit Open
- P0448 Evaporative Emission System Vent Control Circuit Closed
- P0451 Evaporative Emission System Pressure Sensor/Switch Range/Performance
- P0452 Evaporative Emission System Pressure Sensor/Switch Low
- P0453 Evaporative Emission System Pressure Sensor/Switch High

### *Description*

When the engine is running the ECU continuously monitors the status of the evaporative emission components for open circuit or short. The feedback signal should be low when turned ON and high when turned OFF. The following codes will be set if the above conditions are not met.

### **P0444, P0445**

#### *Sensor / component connections*

Purge Solenoid

Connector Pins	Description	ECU Pin	ECU Connector
1	Battery Voltage	-	-
2	Solenoid Output	B3	48 Way (Centre)

#### *Potential failure modes:*

- P0444 Purge valve/wiring open circuit
- P0445 Purge valve short circuit

#### *Diagnostic mask:*

- The MIL will be illuminated if these faults are present for 2 consecutive trips.





## Fuel Level Sensor

- P0461 Fuel Level Sensor "A" Circuit Range/Performance
- P0462 Fuel Level Sensor "A" Circuit Low
- P0463 Fuel Level Sensor "A" Circuit High

### *Description*

When the engine is running the ECU continuously monitors the fuel level sensor feedback signals. The feedback signal should be low when turned ON and high when turned OFF. The following codes will be set if the above conditions are not met.

### *Sensor connections*

Sensor Connector	Description	ECU Pin	ECU Connector
1			
2	Fuel level sensor	A2	48 Way (Right)
3	Fuel level sensor ground.	K3	48 Way (Right)

### **P0462, P0463**

#### *Monitor:*

- Continuous

#### *Enable Criteria:*

- Engine Running

#### *Disable Criteria:*

- None

#### *Malfunction Criteria:*

- P0462 – Voltage < 0.020V, P0463 – Voltage > 0.684V for 1.5 secs

#### *Potential failure modes:*

- Sensor open or short circuit
- Fuel level sensor

#### *Diagnostic Mask:*

- The MIL will be illuminated if these faults are present for 2 consecutive trips.

### **P0461**

The ECU calculates the fuel usage and determines whether the fuel level sensor has responded correctly to this usage. The ECU also monitors the filtered and unfiltered signal at idle after a 20 second de-slosh period and compares the differences.

#### *Monitor:*

- Continuous

#### *Enable Criteria 1:*

- Vehicle Idling
- Vehicle stationary for 20 seconds

#### *Disable Criteria 1:*

- Fuel level < 3.3 litres (0.9 US gallons)

#### *Malfunction Criteria 1:*

- Signal fluctuation > 10 litres, 35 times over 7 second period



### *Enable Criteria 2:*

- 12 litres fuel usage in upper region
- 10 litres fuel usage in lower region
- 5 litres fuel usage in mid region

### *Disable Criteria:*

- Vehicle stopped for 30 secs

### *Malfunction Criteria:*

- Checks for three conditions, stuck when full, stuck when empty or stuck midway. The ECU determines if the sensor is stuck by calculating the amount of fuel used during the test period. If the fuel level does not move by more than 1 litre a fault is flagged.

### *Potential failure modes:*

- Fuel level sensor wiring or connector corroded
- Fuel level sensor stuck

### *Diagnostic Mask:*

- The MIL will be illuminated if these faults are present for 2 consecutive trips.





## Engine Cooling Fan Control

P0480 Fan 1 Control Circuit  
P0481 Fan 2 Control Circuit

### *Component connections*

Sensor Connector	Description	ECU Pin	ECU Connector
	Fan Relay 3	F1	48 Way (Right)
	Fan Relay 2	E2	48 Way (Right)

### *Monitor:*

- Continuous

### *Enable Criteria:*

- Engine running

### *Disable Criteria:*

- None

### *Potential failure modes:*

- Wiring harness problem
- Relay
- ECU

### *Diagnostic Mask:*

- The service light will be illuminated for 30 seconds after engine start if the fault has been present for the previous two trips.



## Vehicle Speed Sensor

P0500 Vehicle Speed Sensor "A"

### *Description*

This input to the ECU is from the ABS module via CAN.

### *Monitor:*

- Continuous

### *Enable Criteria:*

- Following conditions must occur for 5 seconds
- Engine speed > 1800rpm and < 5010rpm
- Baro > 756 mbar
- Engine in a mode that indicates that the vehicle must be moving.

### *Malfunction Criteria:*

- KMH < 5 kmh

### *Potential failure modes:*

- ABS module failure
- CAN bus communication error to ABS controller

### *Diagnostic Mask:*

- The MIL will be illuminated if a fault is present for two consecutive trips.



### Idle Speed Control

- P0506 Idle Air Control System RPM Lower Than Expected  
P0507 Idle Air Control System RPM Higher Than Expected

#### *Description*

The ECM controls the engine idle speed using a combination of spark advance and throttle blade adjustment. If this control cannot attain the desired idle speed a fault is diagnosed.

#### *Monitor:*

- Continuous

#### *Enable Criteria:*

- Engine at idle speed
- Battery voltage between 10 V and 16 V

#### *Malfunction Criteria 1:*

- Idle air learn value on upper limit of +1.8g/s
- Idle speed more than 200 rpm above desired idle speed for more than 5 seconds.

#### *Malfunction Criteria 2:*

- Idle air learn value on lower limit of -1.8g/s
- Idle speed more than 100 rpm below desired idle speed for more than 5 seconds.

#### *Potential failure modes:*

- Induction system air leak
- Excessive engine load from front end accessory drive system, water pump, power steering, alternator
- Electronic Throttle Control

#### *Diagnostic Mask:*

- The MIL will be illuminated if a fault is present for 2 consecutive trips.

#### *Notes:*

There will be a different learn value for AC on and AC off. Either could trigger fault



## A/C Evaporator temperature sensor

- P0537 A/C Evaporator temperature sensor circuit low
- P0538 A/C Evaporator temperature sensor circuit high

### *Description*

The A/C system incorporates an evaporator temperature sensor for system control. This is a thermistor device that changes resistance with temperature. As the evaporator temperature decreases the thermistor resistance value increases, and conversely as the evaporator temperature increases so the thermistor resistance value decreases.

### *Sensor connections*

Sensor Connector	Description	ECU Pin	ECU Connector
1	Sensor signal	A3	48 Way (Right)
1	Sensor ground	K3	48 Way (Right)

### *Monitor:*

- Continuous

### *Enable Criteria:*

- Vehicle Running

### *Disable Criteria:*

- None

### *Malfunction Criteria:*

- P0537 – Signal voltage < 0.049V for 1.5 seconds
- P0538 – Signal voltage > 4.399V for 1.5 seconds

### *Potential failure modes:*

- Thermistor wiring open circuit or shorted
- Thermistor fault

### *Diagnostic Mask:*

- The service light will be illuminated for 30 seconds after engine start if the fault has been present for the previous two trips.



## **Battery Voltage**

- P0562 System Voltage Low
- P0563 System Voltage High

### *Description*

With a battery and alternator functioning as normal the system voltage for a running engine should be around 14V. The ECM monitors this and will diagnose if the voltage is too high or too low.

### *Monitor:*

- Continuous

### *Enable Criteria:*

- Engine running

### *Disable Criteria:*

- None

### *Malfunction Criteria:*

- P0562 – Voltage Too Low < 10V for 10 seconds
- P0563 – Voltage Too High > 16V for 25.5 seconds

### *Potential failure modes:*

- Alternator fault
- Battery fault

### *Diagnostic Mask:*

- The MIL will be illuminated if a fault is present for two consecutive trips.



## Cruise Control

- P0564 Cruise control multi-function input signal
- P0578 Cruise control multi-function input "A" circuit stuck
- P0571 Brake switch "A" circuit

### *Description*

Cruise control requests are made using a multi-function switch input. Each cruise control function switch selects a different resistive network to a single ECM input. From this input the ECM determines the driver request. In addition cruise control is cancelled by the application of either the brake pedal or the clutch pedal (see also P0806, P0807 and P0808).

### *Sensor connections*

Sensor Connector	Description	ECU Pin	ECU Connector
1	Cruise control switch input	E3	48 Way (Right)
2	Cruise control ground	K3	48 Way (Right)
1	Brake Switch Ground	-	-
2	Brake Switch Input	C4	48 Way (Right)

### **P0564, P0578**

#### *Monitor:*

- Continuous

#### *Enable Criteria:*

- None

#### *Disable Criteria:*

- None

#### *Malfunction Criteria:*

- P0564 – Cruise control multifunction switch open circuit or short circuit
- P0578 – Input other than OFF received for more than 100 seconds

#### *Potential failure modes:*

- Cruise switch wiring open circuit or shorted
- Cruise switch fault
- ECU input circuit fault

#### *Notes:*

- The service light will be illuminated for 30 seconds after engine start if the fault has been present for the previous two trips.

### **P0571**

#### *Monitor:*

- Continuous

#### *Enable Criteria 1:*

- KMH > 10 kmh
- PPS > 0.488%

#### *Enable Criteria 2:*

- ABS communications working

#### *Disable Criteria:*

- None



*Malfunction Criteria 1:*

- Brake switch on for greater than 25.5 seconds

*Malfunction Criteria 2:*

- ABS indicating brakes are on but brake switch off for greater than 0.5 seconds

*Potential failure modes:*

- Brake switch wiring open circuit or shorted
- Brake switch fault

*Diagnostic Mask:*

- The service light will be illuminated for 30 seconds after engine start if the fault has been present for the previous two trips.



### **ECU Integrity**

P0601 Checksum  
P0606 Watchdog

#### *Description*

These codes are used by the ECU to check the integrity of the software and calibration data.

P0601 checks that on power up the checksum for calibration data is the same as checksum saved on the previous power down.

P0606 checks the watchdog timer after a defined period to see if it has reset. If the watchdog timer has not reset then the code has entered an unplanned loop or condition stopping it resetting the timer.

#### *Monitor*

- P0601 at ECU power up
- P0606 continuously while the engine running

#### *Diagnostic Mask:*

- The MIL will be illuminated if a fault is present.





### **Variant Code Not Programmed**

P0610 Variant code not programmed

#### *Description*

The ECM programming process includes the Vehicle Variant Code. If a new ECM has been fitted, the relevant variant code needs to be programmed using the Lotus TechCentre tool.

#### *Monitor*

- During start up

#### *Disable criteria*

- None

#### *Potential failure modes*

- Variant code not programmed

#### *Diagnostic mask*

- The MIL will be illuminated if fault is present.

**Crank Relay**

- P0616 Starter relay voltage low  
P0617 Starter relay voltage high

*Description*

When the ignition key is in the crank position battery voltage is applied to the start request input of the ECM. The ECM will then energise the crank relay, via the immobiliser, to allow the starter motor to be engaged. ECM diagnosis is only carried out on the crank relay.

*Component connections*

Relay Connector	Description	ECU Pin	ECU Connector
2	Main relay via fuse R1	-	-
4	Crank relay control	G1	48 Way (Right)

*Monitor:*

- Continuous

*Enable Criteria:*

- Engine running

*Disable Criteria:*

- None

*Potential failure modes:*

- P0616 – Crank relay wiring open circuit or shorted to ground
- P0616 – Fuse R1
- P0617 – Crank relay wiring shorted to 12V
- Crank relay failure
- Immobiliser failure
- ECU output circuit failure

*Diagnostic Mask:*

- The service light will be illuminated for 30 seconds after engine start if the fault has been present for the previous two trips.



## Fuel Pump Relay

- P0628 Fuel Pump "A" Control Circuit Low Voltage
- P0629 Fuel Pump "A" Control Circuit High Voltage

### *Description*

The fuel system is of the non-return type. The fuel pump is incorporated into the fuel tank module, which also contains the level sensor, fuel pressure regulator and vapour pressure sensor. The ECM controls the fuel pump operation via a relay, because of this the only fault diagnosis is of the fuel pump relay.

### *Component connections*

Relay connector	Description	ECU Pin	ECU Connector
1	Rear ignition relay (fuse R7)	-	-
2	Fuel pump relay control	H2	48 Way (Right)

### *Monitor:*

- Continuous

### *Enable Criteria:*

- Ignition on

### *Disable Criteria:*

- None

### *Potential failure modes:*

- P0628 fuel pump relay wiring open circuit or shorted to ground
- P0628 fuse R7
- P0629 fuel pump relay wiring shorted to 12V
- Fuel pump relay failure
- ECU output circuit failure

### *Diagnostic Mask:*

- The MIL will be illuminated immediately if a fault is present.



### **VIN Not Programmed or Incompatible – ECU/PCM**

P0630 Vin not programmed or incompatible

#### *Description*

The ECM programming process includes the Vehicle Identification Number (VIN). If a new ECM has been fitted this operation is performed using the Lotus TechCentre tool.

#### *Monitor:*

- During start up

#### *Enable Criteria:*

- Engine running (for up to 4 seconds)

#### *Disable Criteria:*

- None

#### *Potential failure modes:*

- VIN not programmed

#### *Diagnostic Mask:*

- The MIL will be illuminated if fault is present.



## Throttle Actuator Control Range/Performance

P0638 Throttle actuator control range/performance

### Description

The single throttle butterfly valve mounted at the inlet to the intake plenum is operated by a stepper motor under the command of the engine ECU. The valve moves through a range of nearly 90° and should display 100% at full throttle and around 2% at idle.

### Monitor:

- Continuous

### Enable Criteria 1:

- Engine running

### Disable Criteria 1:

- Electronic throttle fault P2135, P0122, P0122, P0222 or P0223 present
- Throttle demand transient condition

### Malfunction Criteria 1:

- TPS error > 3% for 7.5 secs

### Enable Criteria 2:

- Ignition on

### Disable Criteria 2:

- Electronic throttle fault P2135, P0122, P0122, P0222 or P0223 present

### Malfunction Criteria 2:

- Throttle not able to find closed position during boot

### Potential failure modes:

- Blocked throttle body
- Damage to throttle actuator

### Diagnostic Mask:

- The MIL will be illuminated if fault is present.

Notes: A mechanically sprung 7% throttle opening may be imposed.



## Air Conditioning System

- P0646 A/C Clutch Relay Control Circuit Low
- P0647 A/C Clutch Relay Control Circuit High

### *Description*

The ECM controls the A/C clutch relay in response to the A/C driver request and ECM control logic.

### *Component connections*

<u>Relay Connector</u>	<u>Description</u>	<u>ECU Pin</u>	<u>ECU Connector</u>
1	Ignition supply (fuse R11)		
2	AC clutch relay control	F2	48 Way (Right)

### *Monitor:*

- Continuous

### *Enable Criteria:*

- Engine running

### *Disable Criteria:*

- None

### *Potential failure modes:*

- P0646 – A/C compressor relay wiring open circuit or shorted to ground
- P0646 – Fuse R11
- P0647 – A/C compressor relay circuit shorted to 12V
- A/C compressor relay failure
- ECU output circuit failure

### *Diagnostic Mask:*

- The service light will be illuminated for 30 seconds after engine start if the fault has been present for the previous two trips.



## Variable intake manifold circuit

- P0661 Variable intake manifold circuit voltage low
- P0662 Variable intake manifold circuit voltage high

### *Description*

This circuit opens and closes the variable intake manifold (VIM) in response to changes in the engine speed and load in order to increase the intake efficiency.

When the engine speed is less than 4200 rpm and the engine load is greater than 52%, the ECM turns on the VIM control valve to close the VIM. Under all other conditions, the VIM control valve is usually off and the VIM is open.

### *Component connections*

Connector	Description	ECU Pin	ECU Connector
1	Ignition supply (fuse R8)	-	-
2	VIM control valve control	L4	48 Way (Central)

### *Monitor:*

- Continuous

### *Enable Criteria:*

- Engine running

### *Disable Criteria:*

- None

### *Potential failure modes:*

- P0661 – VIM wiring open circuit or shorted to ground
- P0661 – Fuse R8
- P0662 – VIM circuit, ECM side, shorted to battery voltage
- VIM control valve failure
- ECU output circuit failure

### *Diagnostic Mask:*

- The MIL will be illuminated if a fault is present for two consecutive trips.



## Clutch position sensor circuit

- P0806 Clutch position sensor circuit range/performance
- P0807 Clutch position sensor circuit low
- P0808 Clutch position sensor circuit high

### *Description*

The clutch position sensor is used to identify the position of the clutch (engaged, disengaged or slipping). This information is used to control features such as fuel cut during gear changes, cruise control deactivation and ensuring any torque increase requests from the ESP system only occur with the clutch engaged. The ECM continuously monitors the clutch position sensor input for malfunctions.

### *Component connections*

Connector	Description	ECU Pin	ECU Connector
A	Ground	K3	48 Way (Right)
B	Clutch position sensor signal	B1	48 Way (Right)
C	Reference voltage	F4	48 Way (Right)

### **P0806**

#### *Monitor:*

- Continuous

#### *Enable Criteria:*

- Maximum and minimum clutch position measured over 15 gear changes

#### *Disable Criteria:*

- None

#### *Malfunction Criteria:*

- Voltage difference between maximum and minimum of less than 2.101V

#### *Potential failure modes:*

- Clutch sensor failure
- Clutch pedal failure

#### *Diagnostic Mask:*

- The service light will be illuminated for 30 seconds after engine start if the fault has been present for the previous two trips.

### **P0807, P0808**

#### *Monitor:*

- Continuous

#### *Enable Criteria:*

- None

#### *Disable Criteria:*

- None

#### *Malfunction Criteria:*

- P0807 – Sensor voltage < 0.098V
- P0808 – Sensor voltage > 4.790V





*Potential failure modes:*

- P0807 – Clutch sensor wiring open circuit or shorted to ground
- P0808 – Clutch sensor ECU input circuit shorted to 5V or 12V
- Clutch sensor failure
- Clutch pedal failure
- ECU input circuit failure

*Diagnostic Mask:*

- The service light will be illuminated for 30 seconds after engine start if the fault has been present for the previous two trips.



## Air intake control valve circuit

P1113 Air intake control valve circuit

### *Description:*

The air cleaner is equipped with 2 inlets, one of which is opened or closed by the Air Intake Control Valve (AICV). This system reduces intake noise and increases engine power.

When the engine is operating in the low-to-mid speed range, the ECM deactivates the Vacuum Solenoid Valve (VSV) and allows the AICV to close one of the air cleaner inlets. When the engine speed is greater than a specified value the ECM activates the VSV and the applied vacuum activates the AICV to open both of the air cleaner inlets.

### *Component connections*

<u>Connector</u>	<u>Description</u>	<u>ECU Pin</u>	<u>ECU Connector</u>
1	Ignition supply (fuse R8)	-	-
2	VSV control	B1	48 Way (Central)

### *Monitor:*

- Continuous

### *Enable Criteria:*

- Engine running

### *Disable Criteria:*

- None

### *Potential failure modes:*

- VSV open circuit or short to ground
- VSV circuit short to ECU

### *Diagnostic Mask:*

- The service light will be illuminated for 30 seconds after engine start if the fault has been present for the previous two trips.



## **Misfire**

- P1301 Misfire level causing emissions increase
- P1302 Misfire level causing catalyst system damage

### *Description*

When the engine misfire reaches a high enough percentage the engine emission output levels can exceed the allowed limits, this will produce the fault code P1301.

If the misfire percentage is high enough and there is a possibility that the catalyst may be damaged then code P1302 will be set. To prevent catalyst damage the ECM may take action to either shut down the engine bank containing the misfiring cylinder and limit the engine speed to 4000rpm, or limit the throttle opening if there is more than one cylinder misfiring.

See misfire faults P0300, P0301, P0302, P0303, P0304, P0305, P0306

### *Monitor:*

- Continuous

### *Enable Criteria:*

- Battery voltage between 10 – 16 V
- Coolant temperature between -10 – 120°C (14 – 248°F)
- Engine speed between 480 – 8010rpm
- Engine speed transient > 15rpm
- Altitude < 8000 ft (2438 m) / Baro > 756mbar
- Fuel level > 5 litres (1.3 US gallons)
- Engine load greater than 14 – 25% depending on engine speed

### *Disable Criteria:*

- DFCO enabled (Deceleration Fuel Cut Off)
- Rough road
- MAF faults

### *Malfunction Criteria:*

- P1301 Emissions Failure – Misfire percentage > 7% measured over 1000 engine revolutions.
- P1302 Catalyst Damage Failure – Misfire percentage > 16.6% - 40% depending on engine speed and load, measured over 200 engine revolutions.

### *Potential failure modes:*

- Injector related codes, as these can cause misfire codes to be set.
- VVT codes set
- Sensor connector and wiring for signs of corrosion or loose connections
- Spark plug / cylinder compression
- Cam timing / damage to rocker arm assembly
- Fuel pressure

### *Diagnostic Masks:*

- For a P1301 fault code the MIL will be illuminated immediately.
- For a P1302 fault code the MIL will be illuminated immediately and the ECM will take action to prevent catalyst damage.

### *Notes:*

- Misfire learns are calculated during DFCO (Deceleration Fuel Cut Off)



## Coolant Recirculation Pump

- P2602 Coolant Pump Control Circuit Low
- P2603 Coolant Pump Control Circuit High

### *Description*

During a hot shutdown of the engine, the recirculation pump can continue to pump coolant around the engine. The recirculation pump will run after the engine has been turned off if the enable criteria are matched. The recirculation pump will also run after a short period of idle to aid heater performance.

### *Component connections*

Connector	Description	ECU Pin	ECU Connector
1	Recirc pump driver	M1	48 Way (Right)
2	Main relay via fuse R4	-	-

### *Monitor:*

- Continuous

### *Enable Criteria:*

- P2602 - continuous
- P2603 - engine running

### *Disable Criteria:*

- None

### *Potential failure modes:*

- P2602 – pump wiring open circuit or shorted to ground
- P2602 – fuse R4
- P2603 – pump circuit, ECM side, shorted to battery voltage
- Pump failure
- ECU output circuit failure

### *Diagnostic Mask:*

- The service light will be illuminated for 30 seconds after engine start if the fault has been present for the previous two trips.



**Throttle Actuator Control Motor Circuit/Open**

P2100 Throttle actuator control motor circuit open

*Description*

The throttle actuator stepper motor operates on 12 volts.

*Monitor:*

- Continuous

*Enable Criteria:*

- None

*Disable Criteria:*

- None

*Potential failure modes:*

- Throttle actuator control motor open circuit

**Throttle Actuator Control Motor Circuit/Low**

P2102 Throttle actuator control motor circuit low

*Monitor:*

- Continuous

*Enable Criteria:*

- None

*Disable Criteria:*

- None

*Potential failure modes:*

- Throttle actuator control motor short to ground

**Throttle Actuator Control Motor Circuit/High**

P2103 Throttle actuator control motor circuit high

*Monitor:*

- Continuous

*Enable Criteria:*

- None

*Disable Criteria:*

- None

*Potential failure modes:*

- Throttle actuator control motor short to supply voltage



### Throttle Actuator Control System – Forced Idle

P2104 Throttle actuator control system – forced idle

#### *Description*

If a problem is detected which could result in faster engine speed than commanded by the pedal, the actuator is switched out, allowing the throttle valve to default to a 6% mechanically sprung setting. This provides a fast idle speed which may be used to effect a 'limp home' mechanism.

#### *Monitor:*

- Continuous

#### *Enable Criteria:*

- Engine running

#### *Disable Criteria:*

- None

#### *Potential failure modes:*

- Electronic throttle fault

Note: This code indicates action taken by the ECU, and will always be accompanied by another code which has caused this action.

### Throttle Actuator Control System – Forced Engine Shutdown

P2105 Throttle actuator control system – forced engine shutdown

#### *Description*

If a problem is detected which could result in engine speed runaway, or if sufficient control of engine speed is lost, the ECU switches off the fuel injectors in order to stop the engine.

#### *Monitor:*

- Continuous

#### *Enable Criteria:*

- Engine running

#### *Disable Criteria:*

- None

#### *Potential failure modes:*

- Electronic throttle fault

Note: This code indicates action taken by the ECU, and will always be accompanied by another code which has caused this action.



### Throttle Actuator Control System – Forced Limited Power

P2106 Throttle actuator control system – forced limited power

#### *Description*

If a problem is detected which could result in engine speed control difficulties, the ECU will limit throttle opening to a maximum of 15%.

#### *Monitor:*

- Continuous

#### *Enable Criteria:*

- Engine running

#### *Disable Criteria:*

- None

#### *Potential failure modes:*

- Electronic throttle fault

Note: This code indicates action taken by the ECU, and will always be accompanied by another code which has caused this action.

### Throttle Actuator Control Module Processor

P2107 Throttle actuator control module processor

#### *Description*

The ECU contains two processors dedicated to the throttle pedal and throttle valve potentiometers.

#### *Monitor:*

- Continuous

#### *Enable Criteria:*

- Engine running

#### *Disable Criteria:*

- None

#### *Potential failure modes:*

- ECU internal fault
- Incorrect ECU programming



## Throttle Actuator Control Module Performance

P2108 Throttle actuator control module performance

*Monitor:*

- Continuous

*Enable Criteria:*

- Engine running

*Disable Criteria:*

- None

*Potential failure modes:*

- ECU internal failure
- Short circuit to throttle actuator

## Pedal Position Sensor 'D' Circuit Low

P2122 Pedal position sensor 'D' circuit low

*Description*

Two potentiometers are built into the throttle pedal unit in order to provide a throttle demand signal to the ECU. Note that the potentiometers operate on 5 volts.

*Enable Criteria:*

- None

*Disable Criteria:*

- None

*Potential failure modes:*

- Signal short circuit (< 0.283 V)
- Reference voltage open circuit
- Reference voltage short to ground
- Sensor failure

Notes: A maximum throttle opening of 15% may be imposed due to this single code. In the case of multiple codes, a mechanically sprung 7% opening may be applied.





## **Pedal Position Sensor 'D' Circuit High**

P2123 Pedal position sensor 'D' circuit high

*Enable Criteria:*

- None

*Disable Criteria:*

- None

*Potential failure modes:*

- Signal open circuit (> 4.487 V)
- Reference voltage open circuit
- Reference voltage short to ground
- Sensor failure

Notes: A maximum throttle opening of 15% may be imposed due to this single code. In the case of multiple codes, a mechanically sprung 7% opening may be applied.

## **Pedal Position Sensor 'E' Circuit Low**

P2127 Pedal position sensor 'E' circuit low

*Description*

Two potentiometers are built into the throttle pedal unit in order to provide a throttle demand signal to the ECU. Note that the potentiometers operate on 5 volts.

*Enable Criteria:*

- None

*Disable Criteria:*

- None

*Potential failure modes:*

- Signal short circuit (< 0.283 V)
- Reference voltage open circuit
- Reference voltage short to ground
- Sensor failure

Notes: A maximum throttle opening of 15% may be imposed due to this single code. In the case of multiple codes, a mechanically sprung 7% opening may be applied.

**Pedal Position Sensor 'E' Circuit High**

P2128 Pedal position sensor 'E' circuit high

*Enable Criteria:*

- None

*Disable Criteria:*

- None

*Potential failure modes:*

- Signal open circuit (> 4.487 V)
- Reference voltage open circuit
- Reference voltage short to ground
- Sensor failure

Notes: A maximum throttle opening of 15% may be imposed due to this single code. In the case of multiple codes, a mechanically sprung 7% opening may be applied.

**Throttle Position Sensor 'A'/'B' Voltage Correlation**

P2135 Throttle position sensor 'A'/'B' voltage correlation

*Description*

Two potentiometers are built into the throttle actuator unit in order to provide a throttle position signal to the ECU. Two processors within the ECU compare the two output signals, which should match within a defined tolerance. Note that the potentiometers operate on 5 volts.

*Enable Criteria:*

- None

*Disable Criteria:*

- Throttle position greater than 60%

*Potential failure modes:*

- TPS1 reading incorrectly
- TPS2 reading incorrectly

Notes: A maximum throttle opening of 15% may be imposed.



## Pedal Position Sensor/Switch 'D'/E' Voltage Correlation

P2138 Pedal position sensor/switch 'D/E' voltage correlation

### *Description*

Two potentiometers are built into the throttle pedal unit in order to provide a throttle demand signal to the ECU. Two processors within the ECU compare the two output signals, which should match within a defined tolerance. Note that the potentiometers operate on 5 volts.

### *Enable Criteria:*

- None

### *Disable Criteria:*

- None

### *Potential failure modes:*

- PPS1 reading incorrectly
- PPS2 reading incorrectly

Notes: A maximum throttle opening of 15% may be imposed.

## Throttle Actuator Control System – High Airflow Detected

P2173 Throttle actuator control system – high airflow detected

### *Description*

The mass air flow is compared with the throttle position to determine whether an incorrect correlation exists.

### *Enable Criteria:*

- None

### *Disable Criteria:*

- MAF fault(s) present

### *Potential failure modes:*

- Throttle plate damage
- Air leak in intake system

Notes: A mechanically sprung 7% throttle opening may be imposed, or the injectors may be shut off to stop the engine.

**A/C Refrigerant Distribution Valve**

P2612 A/C Refrigerant Distribution Valve Control Circuit Low  
P2613 A/C Refrigerant Distribution Valve Control Circuit High

***Description:***

The A/C refrigerant flow is regulated by the ECM using the distribution valve to control the evaporator to the required temperature and prevent freezing.

***Component connections:***

<u>Connector</u>	<u>Description</u>	<u>ECM Pin</u>	<u>ECM Connector</u>
1	Control valve driver	K3	48 Way (Centre)
2	Ignition via rear ign relay	-	-

***Monitor:***

- Continuous

***Enable Criteria:***

- Engine running

***Disable Criteria:***

- None

***Potential failure modes:***

- P2612 – valve wiring open circuit or shorted to ground
- P2612 – loss of power from rear ignition relay
- P2613 – valve circuit, ECM side, shorted to battery voltage
- Valve failure
- ECM output circuit failure

***Diagnostic Mask:***

- The service light will be illuminated for 30 seconds after engine start if the fault has been present for the previous two trips.



## A/C Compressor Lock Sensor Circuit

B1422 A/C Compressor Lock Sensor Circuit

### *Description:*

The ECM monitors the A/C compressor speed. If this speed is lower than the engine speed the ECM will turn off the A/C compressor clutch. This is to prevent belt damage due to slippage.

### *Component connections:*

Connector	Description	ECM Pin	ECM Connector
1	Lock sensor +ve	C1	32 Way (Left)
2	Lock sensor -ve	B1	32 Way (Left)

### *Monitor:*

- Continuous

### *Enable Criteria:*

- Engine running

### *Disable Criteria:*

- P0646, P0647 A/C compressor clutch fault

### *Malfunction Criteria:*

- A/C compressor speed error greater than 20%

### *Potential failure modes:*

- A/C compressor clutch mechanism slipping or seized
- A/C compressor drive belt slipping
- Lock sensor wiring
- Lock sensor failure
- ECM input circuit failure

### *Diagnostic Mask:*

- The service light will be illuminated for 30 seconds after engine start if the fault has been present for the previous two trips.

**Lost Communications with TCM**

U0101 Lost Communications with TCM

*Description:*

The ECM communicates with the Transmission Control Module (TCM) via the CAN bus. If these CAN bus communications have been interrupted the ECM will register a diagnostic code.

*Potential failure modes:*

- CAN wiring
- TCM control module failure
- CAN bus corruption by another module on bus

*Diagnostic Mask:*

- The service light will be illuminated for 30 seconds after engine start if the fault was present on the previous trip.

**Lost Communications with VDCM**

U0122 Lost Communications with VDCM

*Description:*

The ECM communicates with the Vehicle Dynamic Control Module (VDCM) via the CAN bus. If these CAN bus communications have been interrupted the ECM will register a diagnostic code.

*Potential failure modes:*

- CAN wiring
- VDCM control module failure
- CAN bus corruption by another module on bus

*Diagnostic Mask:*

- The service light will be illuminated for 30 seconds after engine start if the fault was present on the previous trip.

**Lost Communications with TPMS**

U0127 Lost Communications with TPMS

*Description:*

The ECM communicates with the Tyre Pressure Monitor System (TPMS) via the CAN bus. If these CAN bus communications have been interrupted the ECM will register a diagnostic code.

*Potential failure modes:*

- CAN wiring
- TPMS control module failure
- CAN bus corruption by another module on bus

*Diagnostic Mask:*

- The service light will be illuminated for 30 seconds after engine start if the fault was present on the previous trip.



### **Software Incompatible with VDCM**

U0316 Software Incompatible with VDCM

*Description:*

The ECM checks that the Vehicle Dynamic Control Module (VDCM) matches the vehicle variant code. If not the above code will be set and the ECM will not respond to torque requests from the VDCM.

*Potential failure modes:*

- The ECM has been programmed with an incorrect variant code which does not match vehicle VDCM level.
- VDCM error.

*Diagnostic Mask:*

- The service light will be illuminated for 30 seconds after engine start if the fault was present on the previous trip.

EMR.2 - CAN BUS DIAGNOSTICS; LOTUS TECHCENTRE

Controller Area Network (CAN) is an electronic standard to allow high speed communication between modules and controllers, via a serial data bus. The bus is a circuit linking the modules to the controller, consisting of a pair of cables, twisted together to reduce electromagnetic interference, and carrying a square wave voltage signal corresponding to '0's and '1's, coded in such a way as to identify and prioritise the individual messages. On the Evora, CAN based systems include; engine management, safety restraint, anti-lock braking and related features, instrument pack, and onboard diagnostics.

A 'stand alone' lap top PC loaded with 'Lotus Techcentre' software allows the CAN based serial data to be read. A Vehicle Communication Device (T000T1472F) introduced for the Europa model is used to connect the vehicle to the laptop Lotus Techcentre. Engine programming, live data display, diagnostics of engine, ABS and airbag systems, are all carried out via the Lotus Techcentre.

The minimum specification of the laptop computer for installation of the Lotus Techcentre is as follows:

- Processor 1.70 Ghz;
- 1 GB RAM;
- 40 GB HDD;
- CDRW DVD ROM;
- WIN XP PRO;
- USB interface;
- Ethernet or Wireless LAN

Note that this laptop should be dedicated totally to the Lotus Techcentre, with no other software installed.





TRANSMISSION

SECTION FL

	<u>Sub-Section</u>	<u>Page</u>
Introduction	FL.1	3
Gearchange Mechanism	FL.2	3
Lubrication	FL.3	6
Driveshafts	FL.4	6
Transmission Removal/Replacement	FL.5	10
Transmission Overhaul	FL.6	10



**GENERAL LAYOUT**

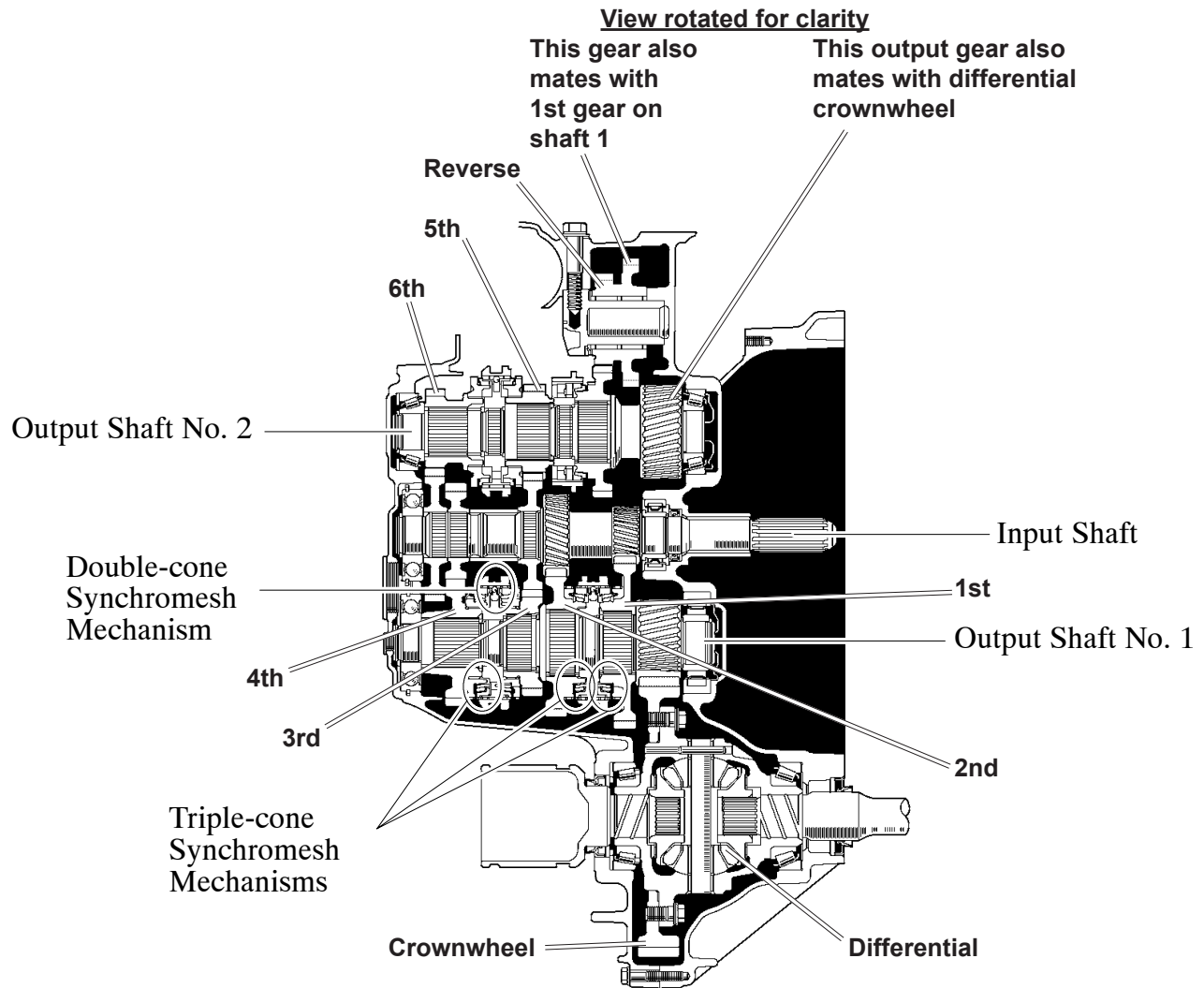



## FL.1 - GENERAL DESCRIPTION

The 6-speed transmission assembly is an 'end on' type, positioned at the left hand side of the powertrain, and is supplied by the Toyota Motor Corporation under the designation EA60. The unit is fully described on CD Lotus part number T000T1507 (Toyota ref. SC02J1EA).

Insert the disc into a personal computer, and it will automatically open up to an Avensis menu page. Select:

- New Car Features Supplement.
- 2005.04 Update.
- New Features.
- Manual Transaxle.
- EA60 and EA61 Manual Transaxle (disregard shift lever description).

Note that the EA60 transmission is not used by Toyota in combination with the 2GR-FE V6 engine. For the Evora application, a fully machined, cast alloy adaptor plate is interposed between the engine and transmission, the clutch housing of which is machined to accept the mounting of the starter motor via a further adaptor block.

The transmission serial number is engraved on the top surface of the transmission front case, alongside the jointline with the rear case. Typical example: A7H05232

## FL.2 - GEARCHANGE MECHANISM

Two control cables run along the centre of the cabin and beneath the fuel tank and power unit, and transmit the movement of the gearchange lever to the transmission selector housing.

The gear lever is spring biased towards the 3rd/4th gear plane, by springs at both the lever end, and within the transmission. The lever must be moved against light spring pressure to the left before selecting first or second gear, or against similar pressure to the right before selecting 5th or 6th speed.

### Engaging Reverse Gear:

With the vehicle at a **complete standstill**, pause for a moment with the clutch pedal fully depressed before moving the lever to the left, raising the lift collar beneath the knob, and then further to the left over a spring detent before finally pushing forwards to engage the gear.

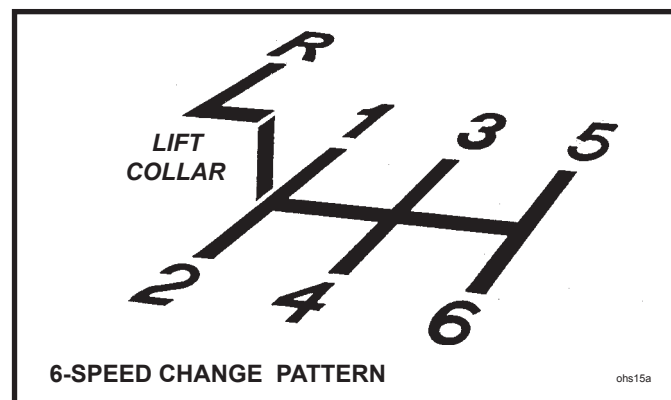

A two cable mechanism is used to connect the gearchange lever with the transmission, one cable ('shift') to transmit the fore/aft movement of the lever, and a second ('crossgate') cable for the sideways movement. The gearchange lever is pivoted at its base and operates the shift cable directly via a ball joint half way up the lever. The base of the lever has an extended ball pin on the right hand side which engages with a crossgate bellcrank lever, the other leg of which operates the crossgate cable.

An inhibit mechanism prevents the gear lever being moved into the reverse gear plane unless a collar beneath the gear knob is lifted. This action raises a boss at the base of the lever above a curved inhibitor block, allowing the lever full leftward movement.

The front end of both inner cables are equipped with socket joints which engage with ball pins fitted on the gearchange mechanism. The outer cables are retained by a forked plastic block bolted into the gearlever/handbrake mounting frame.

At the transmission end, each outer cable is located in an abutment bracket by a spring 'C' clip, with the eye of the inner cable retained in its selector lever by a washer and 'R' pin. The shift cable connects directly to a lever on the cross-shaft to cause its rotation, the action smoothed by an extension to the lever carrying a damper mass. The crossgate cable connects to a bellcrank lever which imparts an axial motion to the cross-shaft.

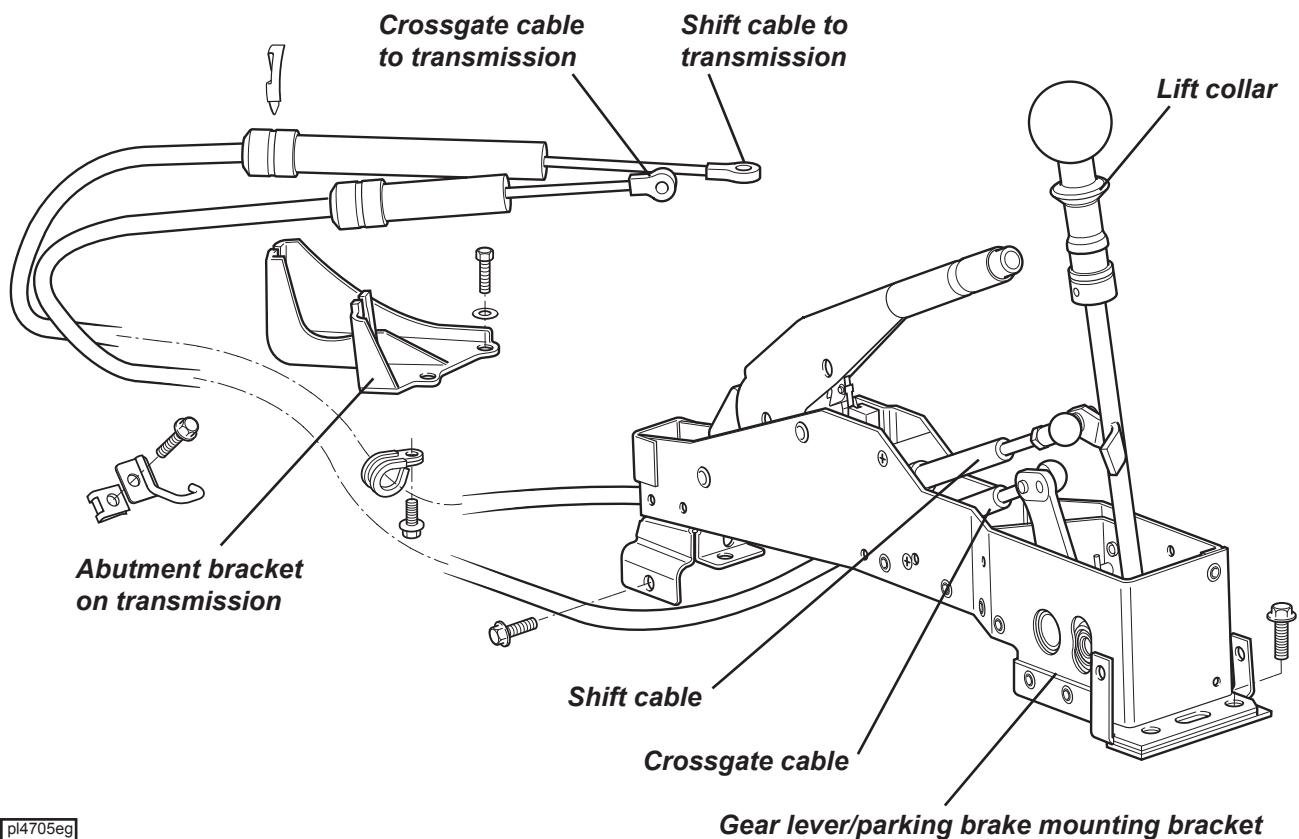

pl4705eg

### Gearchange Cable Adjustment

In order to ensure smooth selection of 1st/2nd gears, it is important to set the crossgate cable adjustment in relation to the fixed position reverse inhibitor block.

- Push the lever to the left to abut against the reverse inhibitor block, and check selection of 1st and 2nd gears. There should be no obstruction to fore/aft movement of the lever.
- If fore/aft baulking occurs, determine whether the 1st/2nd unobstructed plane is too far left or right of where it needs to be (i.e. adjacent to the inhibitor block). For example, if smooth operation can be achieved only when the lever is moved slightly away from the inhibitor, the plane needs to be moved leftwards. Remove the gear lever shroud. Release the ball pin from the crossgate bellcrank lever, loosen the locknut and to move the plane to the left, screw the ball joint socket further onto the cable by one turn clockwise. To move the plane to the right, turn counter-clockwise before re-attaching to the bellcrank and testing. Once a setting is found which allows smooth fore/aft lever movement whilst abutting against the inhibitor block, secure the ball joint socket with the locknut. Note that adjustment is available also at the transmission end of the cable.
- Raise the reverse inhibit gear lever collar and check that reverse gear can be engaged.
- Refit the shroud and check that all gears can be selected without the lever fouling the shroud aperture. If necessary, fit shim washers behind the reverse inhibitor block to move the lever away from the LH side of the aperture and re-adjust the crossgate cable as necessary.
- If other adjustments have been made, check the alignment of the 3rd/4th lever plane. From the spring loaded neutral position, it should be possible to smoothly engage 3rd and 4th gears without moving the lever across the gate. If necessary, the ends of the centralising hairpin spring may be reprofiled to reset the neutral plane.

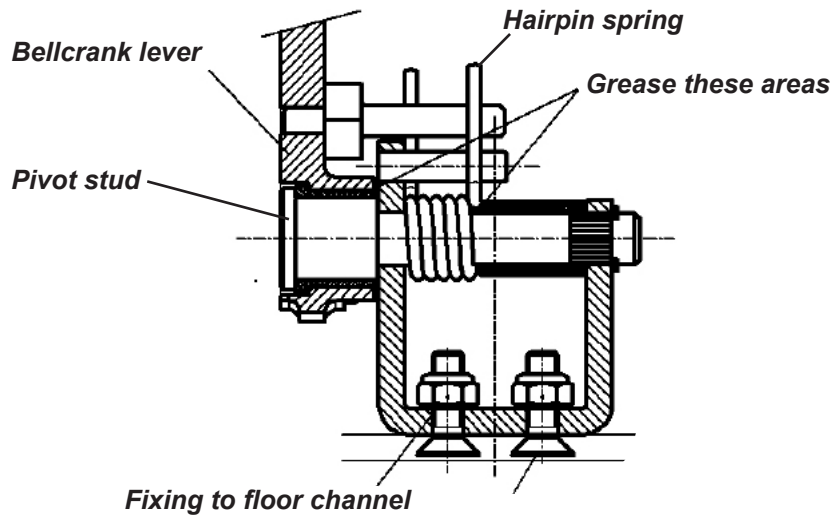

**Gearchange Cable Replacement**

For access to the gear cables, the gear lever shroud and parking brake lever trim panel must be removed, and the gear lever/parking brake support channel released from the chassis tub floor:

- *Remove centre console:* See sub-section VE.5.
- *Remove the engine bay undertray.*
- *Release cables, front:* Disconnect the front end of each cable by prising off the end socket from its gear lever or crossgate lever ball pin. Release the outer cable abutment clamp from the mounting frame. Also release the parking brake cable from the lever and disconnect the parking brake tell tale switch.
- *Mounting frame:* Release the gear lever mounting frame from the support channel, and withdraw.
- *Release the support channel:* Remove the 12 screws securing the support channel to the floor of the chassis tub to allow the gear cables to be released from the 'P' clips inside the support channel.
- *Release cables, rear:* Release the cables from the transmission levers and abutment bracket by removing the 'R' clips and 'C' clips respectively. Release all cable retaining clips and ties, and remove the cables from the car.

Refit the cables in reverse order to removal, and check adjustment as detailed above.



**FL.3 - LUBRICATION**

The engine and transmission should be inspected for evidence of oil leaks at every service, and the transmission oil renewed at intervals specified in the Maintenance Schedule.

The transmission should be drained after a run when the oil is warm, flows more readily, and the impurities are still held in suspension. A hex. head drain plug is provided in the bottom of the transmission crownwheel housing. After allowing a sufficient drain period, thoroughly clean the drain plug before applying PTFE tape around the thread, fitting a new sealing washer and tightening to 39 Nm.

A level/filler plug is located in the left hand side of the transmission case. With the vehicle at normal ride attitude, the oil level should be within 5mm of this filler plug hole. For oil specification refer to Section OK. After refilling, re-check the oil level at normal running temperature after a run. Finally use a new sealing washer and tighten to 39 Nm.

**FL.4 - DRIVE SHAFTS**

Each of the two driveshaft assemblies comprises a steel shaft with a constant velocity (CV) joint at each end, and is used to transmit the drive from each differential output gear to the rear wheel hub. The longer right hand driveshaft assembly features an outrigger bearing bolted to the right hand side of the cylinder block, with a shaft extending from the inboard CV joint into the transmission housing.

The inboard joints are of a plunging tripod design to accommodate driveshaft length variation with suspension travel, whereas the outboard joints are high efficiency 6-ball fixed length type. Replacement outboard joints include the main driveshaft, outboard C.V. joint and gaiter. Replacement inboard joints include the inner C.V. joint and gaiter kit, with the extended stub shaft of the RH joint also including the support bearing and mounting bracket.

The joints themselves are packed with grease on initial assembly, and are maintenance free. It is however vitally important that the protective gaiters are carefully inspected at service intervals, to check for splits, tears or punctures, since the joint will deteriorate very quickly once contaminated with dirt or water. Damaged gaiters should be renewed immediately, once the servicibility of the joint has been established.

**CAUTION:** The outboard C.V. joint gaiter can suffer 'pinch' damage if the joint is subjected to extreme articulation off the car, or during driveshaft removal/refitment.

**LH Driveshaft Assembly**

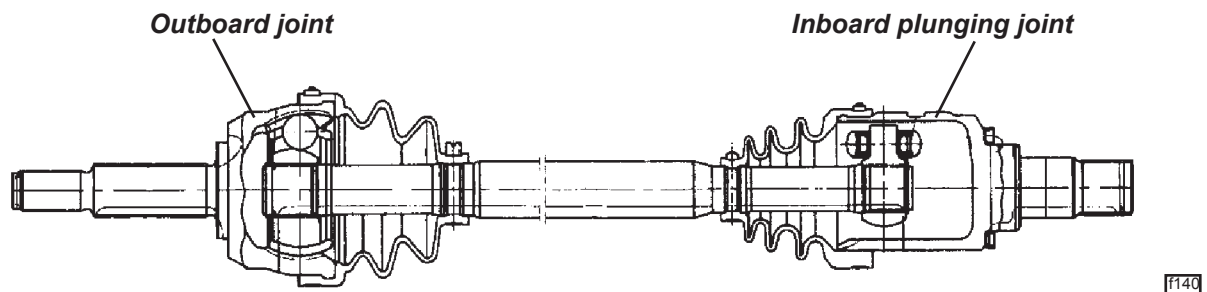

**RH Driveshaft Assembly**

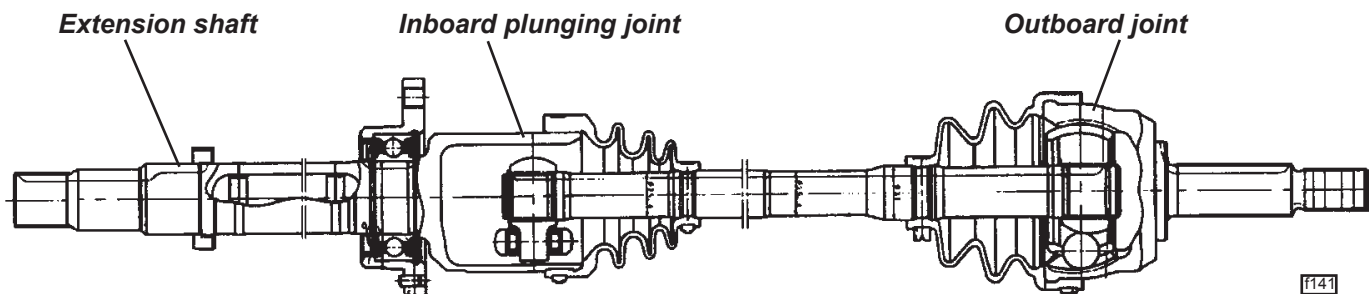



Clicking noises, torque reversal 'clonks', or shudder and vibration when accelerating are all possible symptoms of worn C.V. joints. It should not be possible to discern any free play in a joint by manual manipulation, but care must be taken not to confuse this with transmission backlash, which may be considerable. Any symptoms that could be due to worn driveshaft joint assemblies, should be investigated and rectified without delay, since safety considerations are always of paramount importance.

The inboard C.V. joint is equipped with a male splined spigot shaft which engages with the female splines of the differential output sun gear, with the LH shaft retained by a round section spring circlip on its end, and the RH shaft retained by the extension shaft support bearing. Each of the two transmission output oil seals runs on a machined shoulder on the C.V. joint spigot shaft, onto which is pressed a dust shield. The stub shaft of each outboard joint is splined into the wheel hub, and retained by a nut on the threaded end of the shaft.

### Driveshaft Assembly Replacement

Removing a driveshaft assembly from the transmission will result in some loss of transmission lubricant. It may be preferred to drain off some oil via the transmission drain plug beforehand. At no time during this process should an extension force be applied to the shaft assembly, as the plunging inner joint could be damaged.

1. *Hub Nut:* With the parking brake and footbrake firmly applied, remove the wheel centre cap and release the driveshaft hub nut (RH thread at both sides).
2. *Road Wheel:* Remove the appropriate road wheel and the engine bay undertray.
3. *Hub Carrier:* To allow the withdrawal of the driveshaft from the hub, release from the hub carrier the lower wishbone, toe-link, and anti-roll bar drop link. If necessary, release the brake hose 'P' clip and the wheel speed sensor harness to allow the hub carrier to be swung upwards to release the driveshaft.
4. *Lubricant:* Remove transmission drain plug and drain off approx. 1 litre of oil into a clean container for re-use.
5. *LH Driveshaft:* The left hand driveshaft inboard joint is retained in the transmission by a round section circlip. The joint may be removed by applying a shock pull to the C.V. joint body using a slide hammer with a forked end.

**CAUTION:** Any attempt to withdraw the inboard joint by pulling on the driveshaft is likely to damage the joint and require its replacement. Apply pressure only to the outer body of the joint.

*RH Driveshaft:* The right hand driveshaft assembly incorporates a bearing for the extension shaft and it is this which retains the shaft in the transmission. Remove the two bolts securing the bearing housing to the engine, and withdraw the complete shaft assembly.

When withdrawing either driveshaft from the transmission, take care not to damage the output oil seal.

6. *Re-assembly:* Before re-fitting a driveshaft, first renew the round section circlip on the end of the left hand inboard joint spigot shaft, and lubricate the circlip with grease. Also, check the condition of the transmission output seal, and renew if necessary. Lubricate the lip of the seal with transmission oil, and grease the corresponding shoulder on the driveshaft (C.V. joint) to reduce the danger of damaging the seal on assembly.
7. *Driveshaft:* Carefully insert the driveshaft into the transmission, with, on the left hand shaft, the two ends of the circlip positioned lowermost, and rotate the shaft if necessary to engage the splines. Press the inboard joint outer until a click indicates the engagement of the retaining circlip, if necessary tapping the joint outer body using a brass drift and hammer. Pull on the joint body to confirm its security. On the right hand shaft, fit the bolts securing the extension shaft bearing to the engine mounted bracket, and torque to 64 Nm.
8. *Suspension:* Fit the outer end of the shaft into the hub, and re-assemble the suspension links.  
Torque settings: Lower wishbone to hub carrier; 135 Nm. Toe-link to hub carrier; 135 Nm. ARB drop link; 38 Nm.
9. *Hub Nut:* Fit the hub nut and road wheel, apply the parking and footbrake, and tighten the hub nut to 300 Nm.



10. *Lubricant:* With the car on the level, top up the transmission oil to the filler/level plug hole (see above).
11. *Wheel and Undertray:* Refit the road wheel and undertray.

### Driveshaft C.V. Joint and/or Gaiter Replacement

The outboard C.V. joint is supplied complete with main driveshaft to which it is fixed by a spline with a small helix angle to eliminate any potential backlash. Separation of the shaft from the joint should not be attempted. Replacement of the outboard joint gaiter entails removal of the complete driveshaft assembly from the car, and separation of the inboard joint from the shaft.

1. Remove the driveshaft assembly from the car (see above).
2. Remove the clips securing the inboard joint gaiter without damaging the gaiter if it is to be re-used. Pull the gaiter off the joint outer body and match mark the body to the joint spider before disengaging the joint.
3. Match mark the inboard joint spider to the shaft before removing the snap ring from the end of the shaft, and withdrawing the spider assembly.
4. Slide the inboard gaiter off the shaft, remove the outboard gaiter clips and slide off the outboard gaiter.
5. *Inspection & Cleaning:* Complete disassembly of either joint is NOT recommended. The separate components are a precision fit and develop their own individual wear patterns, such that any interchanging or re-orientation of parts is likely to result in premature failure.  
If the grease in the joint is contaminated with dirt or water, it is likely that the joint is damaged, and should be replaced. If the grease is not contaminated, the joint should be degreased by soaking in a suitable solvent (NOT petrol), and then carefully inspected. Tilt the ball type inner race or spider rollers to one side to expose each driving surface. Severe pitting, galling, play between ball and its cage window, any cracking or damage to the cage, or pitting, galling or chips in raceways, call for joint replacement.  
If the joint is found to be serviceable, it must be repacked with the special grease provided. Pack the grease into the joint itself and also into the inside of the new gaiter.  
NOTE: The grease provided in the kits is specially formulated for wear resistance and durability. DO NOT use substitutes or mix with other lubricants. The grease specification and quantity also differs for inboard and outboard joints:  
Inboard: 180g NKG302  
Outboard: 180g NTG2218-M (inboard grease is also supplied in outboard kits, as the inboard joint must be removed before fitting outboard gaiter)
6. Slide the new outboard gaiter and smaller retaining clip onto the shaft. Fit the gaiter into the grooves on the outboard joint body and the driveshaft, and secure with the clips provided.
7. Slide the new inboard gaiter and retaining clips onto the driveshaft. Press the spider onto the driveshaft splines with the match marks aligned, and retain with a new snap ring.
8. Fit the spider into the inboard joint body with the match marks aligned, position the gaiter in the location grooves, and retain with the new clips.
9. Refit the driveshaft to the car (see above).

### Extension Shaft Support Bearing

The ball bearing supporting the RH driveshaft extension shaft to the engine block is mounted in a housing which is bolted to a bracket on the engine block. The bearing is sealed and maintenance free, and is included as part of the inboard C.V. joint assembly, but may if necessary be renewed by the following procedure:

1. Remove the RH driveshaft assembly (see above).
2. Using a press, remove the dust shield from the inboard end of the shaft.





3. Remove the circlip from the outboard face of the bearing housing, and press or pull the housing from the bearing.
4. Prise or pull the bearing dust shield off the shaft.
5. Remove the circlip retaining the bearing and press or pull the bearing from the shaft.

6. Press a new bearing into the housing, and retain with a new circlip. Then use special press tool T000T1438F to press the inner race of the bearing up to the shoulder on the shaft, and retain with a new circlip.

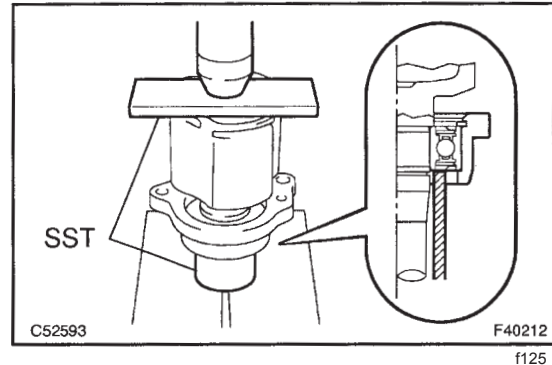

7. Use special press tool T000T1439F to press the bearing dust shield onto the shaft and position as shown in the illustration.

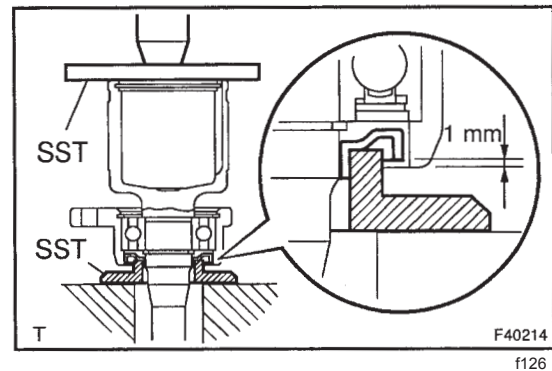

8. Press the inboard dust shield onto the end of the shaft to the dimension shown in the illustration.
9. Refit the driveshaft to the car (see above).

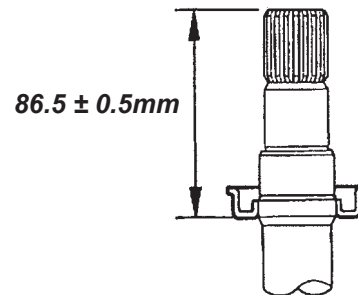



### FL.5 - TRANSMISSION REMOVAL/REPLACEMENT

The transmission may be separated from the engine only after removal of the complete powertrain from the car. See sub-section EJ.5.

#### **To separate the engine/transmission assembly**

In order to mate the 2GR-FE engine to the EA60 manual transmission for use in the Evora, a Lotus specific fully machined cast alloy adaptor plate is used between the two units. Space to mount the starter motor in the position ordained by the clutch housing, is not available with the 2GR-FE engine, so a special machined casting is used to mount an opposite rotation starter motor alongside the clutch, the housing for which is machined to provide suitable clearance.

After removal of the complete powertrain assembly:

1. Remove the clamp bracket supporting the end of the starter motor body.
2. Release the two bolts securing the starter motor flange to the adaptor bracket, and withdraw the motor.
3. Remove the two bolts securing the motor adaptor bracket to the transmission adaptor plate, and remove the bracket.
4. Ensure suitable independent support of the engine and transmission units before releasing the clutch housing from the engine:
  - From beneath, remove the two bolts securing the dirt shield in the clutch housing aperture.
  - Remove the 3 bolts from the engine side of the lower section of the adaptor plate.
  - Remove the 5 bolts from the transmission side securing the clutch housing to the engine/adaptor plate.
  - Withdraw the transmission from the engine.
5. If necessary, release the 3 x M12 bolts from the transmission side securing the adaptor plate to the engine, and the single M10 bolt from the engine side of the plate. Remove the plate.

On re-assembly, torque all M12 fixings to 65 Nm, and M10 fixings to 45 Nm. Re-seal around the starter motor to reduce the ingress of water into the clutch housing.

### FL.6 - TRANSMISSION OVERHAUL

For transmission repair and overhaul procedures, refer to Lotus CD part number T000T1507F (Toyota ref. SC02J1EA). Insert the disc into a personal computer, and it will automatically open up to an Avensis menu page. Select:

- Repair Manual Supplement.
- 2005.4 -
- TRANSMISSION.
- EA60 / EA61 MANUAL TRANSAXLE
- Select the operation required.



**WHEELS & TYRES**

SECTION GJ

	<u>Sub-Section</u>	<u>Page</u>
General Description	GJ.1	2
Tyre Pressure Monitoring System (TPMS)	GJ.2	2
Wheels	GJ.3	3
Wheel Bolts	GJ.4	4
Tyres	GJ.5	4
Winter Tyres & Snow Chains	GJ.6	5
Punctured Tyre Emergency Inflator	GJ.7	6



## GJ.1 - GENERAL DESCRIPTION

The single piece, light alloy roadwheels are factory fitted with tyres engineered to provide the optimum balance of ride and handling characteristics. In order fully to exploit the dynamic qualities and packaging opportunities, the wheel and tyre sizes are different front and rear, so that interchanging of wheels and tyres between axles is not permissible. Note that the tyre tread pattern is asymmetric across the width, with the sidewalls marked 'side facing inwards' or 'side facing outwards', but the tyre may rotate in either direction.

The tyres should be inspected frequently by the vehicle user, and also at every service, for signs of cuts, abrasions or other damage, and for any uneven tread wear patterns. Uneven treadwear may indicate that the suspension geometry or dampers require attention. Care should be taken when parking to avoid tyre contact with high or sharp edged kerbs, as mistreatment of this nature can cause internal damage to the tyre structure which may not readily be apparent. The alloy wheel rims may also be distorted or damaged by careless parking, and result in wheel imbalance or loss of tyre pressure. Safety considerations should always be paramount when assessing tyre condition and serviceability, and the tyres replaced if any doubt exists, or if the legal tread depth limits are approached.

The cold tyre pressures should be checked every week, or every 1,000 miles (1,700 km), whichever is the sooner, and corrections made as necessary. Under-inflation will cause excessive wear, rapid deterioration of the tyre sidewalls and heavy steering, whereas overinflation results in a hard ride and increased susceptibility to tyre damage. Both conditions will cause a degradation in the vehicle handling qualities. It is important that the tyre pressures are adjusted only when the tyres are cold (driven less than one mile), as the pressures may increase by 0.3 - 0.5 bar (4 - 8 lb/in<sup>2</sup>) when the tyres are warmed to normal running temperature. The tyre valve dust cap should always be replaced in order to prevent the ingress of dirt and moisture into the valve, which could cause leakage.

When balancing the wheel and tyre assemblies, the wheels should be located by the centre spigot - NOT by the wheel bolt holes. In order to maintain the correct handling feel and minimum steering wheel shake, it is very important that the radial and lateral run out of the tyres are to the high standard required by Lotus Cars. If any difficulty is experienced with replacement tyres, refer to the tyre manufacturer.

The Yokohama Advan Sport tyres fitted to the Evora are suitable for all normal weather conditions. The tyre characteristics include good feedback ('feel') from the road surface to the steering wheel, a high level of steering linearity and response, and little performance degradation with the high temperatures which may be reached in sports use. However, tyre performance will decrease at low ambient temperatures, resulting in reduced levels of grip and an increased susceptibility to damage from impacts. In these conditions, especially below -7°C, it is recommended to fit a car set of the recommended winter tyres (see below).

## GJ.2 - TYRE PRESSURE MONITORING SYSTEM (TPMS) - Where fitted

A sensor incorporated into each of the tyre valves, monitors the air pressure inside the tyre, and supplies an onboard control module located on the LH rear wheelarch with this data by radio transmission. Tyre pressure information is displayed in the instrument cluster right hand screen. A silhouette of the vehicle showing each wheel, will display all four tyre pressures for one minute following ignition switch on.

If any tyre pressure should fall below 75% of the recommended value, an alert message is sent to the instrument panel, and the tyre pressure tell tale  will light up amber. The corresponding tyre on the silhouette will be highlighted and the pressure displayed.

If this warning should occur, the car should be stopped as soon as it is safely possible, and the affected tyre examined. If there is no visible damage and a tyre pump is available, the pressure should be corrected (see below), before proceeding with caution to a tyre repair/replacement facility. Note that the tell tale will automatically be extinguished when the correct pressure is restored. If the tyre is punctured, or no inflation equipment is available, use of the emergency tyre inflator aerosol (see below) should be considered, whilst being aware that the TPMS sensor in the tyre would be disabled by the sealing fluid, and would subsequently require replacement.

The TPMS incorporates self-malfunction recognition, and if a fault is detected, the low tyre pressure tell tale in the instrument panel will flash for one minute, and then remain constantly lit, this sequence being repeated for subsequent ignition cycles; **with the tell tale flashing or lit, there may be no detection of low tyre pressure.**



When removing or replacing a tyre, be aware that the tyre valve includes a pressure transducer and should not be discarded. Take care not to damage the sensor with the tyre bead or tools. If a fault is indicated after wheel or tyre replacement, it is likely that a sensor has been incorrectly fitted or damaged. If a tyre valve/sensor is renewed, or is moved to a different wheel position, the TPMS will automatically identify the new configuration by interpreting signal strength as distance from sensor to receiver.

Note that the pressure sensors are powered by integral batteries, with an average service life of 10 years. It is recommended to renew all pressure sensors at this time interval.

### TPMS fault codes

On detection of a fault, the TPMS integrated diagnostics will set an appropriate code which may be read using the Lotus Techcentre:

- C0550 TPMS ECU Failure
- C0551 TPMS Module not programmed with Vehicle Configuration
- C0558 TPMS Vehicle Sensor ID's not programmed
- C075A TPMS Pressure Sensor LF Malfunction / Battery Low / Broken Shock Sensor
- C075B TPMS Pressure Sensor RF Malfunction / Battery Low / Broken Shock Sensor
- C075C TPMS Pressure Sensor LR Malfunction / Battery Low / Broken Shock Sensor
- C075D TPMS Pressure Sensor RR Malfunction / Battery Low / Broken Shock Sensor
- C0777 TPMS Sensor Autolocation Failed
- C0800 TPMS Module Supply Voltage Below 9V / Above 18V
- U2103 TPMS Communications Malfunction

In the first instance, the car should be driven gently at 40 mph in order to optimise conditions for sensor recognition. If the fault persists, the following action should be considered:

- 550/551/558 – most likely a TPMS module problem; renew
- 75A/B/C/D – most likely a pressure sensor; renew
- 777 – Most likely the module but could be a rogue sensor
- 800 – Check supply voltage and ground connection
- U2103 – Could be module, CAN cable connection or engine T4e controller

### GJ.3 - WHEELS

Standard wheels on the Lotus Evora are Lotus styled, cast alloy, 10-spoke arranged in pairs, silver or grey painted, in sizes of 8.0J x 18 front, and 9.5J x 19 rear. Optional forged alloy wheels are Lotus styled with 10 equally spaced radial spokes, but are otherwise similar. Each wheel is located by a central spigot and secured by five bolts, four of which have a spline socket head, and one with a security coded head. A splined extension tool and a coded adaptor are supplied with the vehicle and require a 17mm hex. socket, square drive extension and a torque wrench.

Type	- std	Cast alloy, 10 spokes in pairs, silver or grey, 5-bolt fixing.
	- optional	Forged alloy, 10 radial spokes, silver or grey, 5-bolt fixing.
Size	- front	8.0J x 18H2
	- rear	9.5J x 19H2
Inset	- front	+ 52 mm
	- rear	+ 69 mm
PCD		114.3 mm
Wheel bolts	- thread	M12 x 1.5 x 26 mm
	- torque	105 Nm
	- seat	60° taper
Centre spigot hole diameter		68 mm
Radial run-out at bead seat		0.3 mm max.
Lateral run-out at bead seat		0.3 mm max.



Note that the inset figure is the displacement of the wheelrim centreline relative to the wheel/hub mounting face. A positive inset indicates that the wheelrim centreline lies inboard of the wheel mounting face, whereas a negative inset means the wheelrim centreline is outboard of the mounting face.

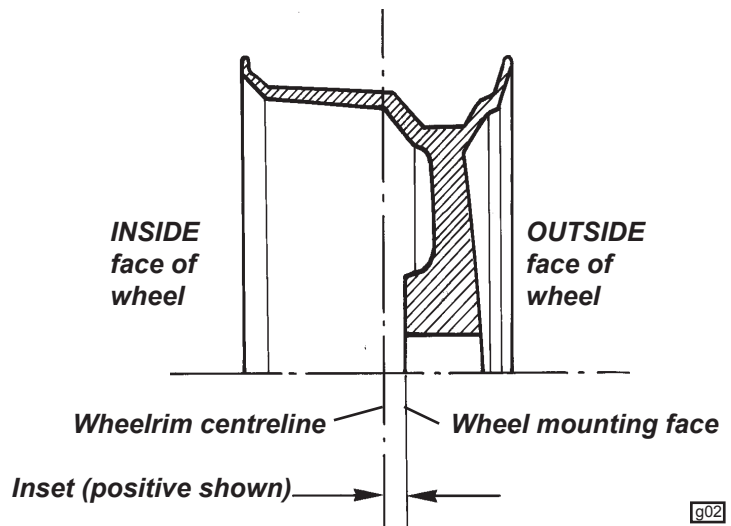

**GJ.4 - WHEEL BOLTS**

The wheel bolts used are of a special design to suit the small diameter fixing tunnels in the wheel centres. The bolts have an M12 x1.5 thread, 60° conical seat, and a 10 spline socket head for which a special extension tool is supplied with the car.

A 17 mm a/f deep socket and 1/2 inch square drive torque wrench should be applied to the extension tool, with a tightening torque of 105 Nm required.

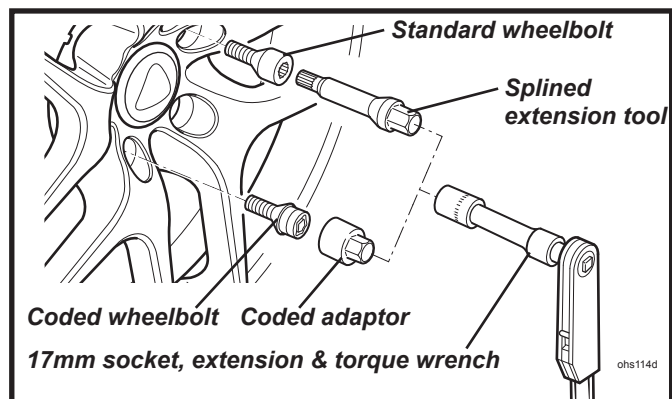

To protect against wheel theft, one of the five bolts securing each wheel is key coded, and requires a correspondingly coded adaptor tool. Fit the adaptor tool onto a 1/2 inch square drive extension, and rotate the adaptor until full engagement into the bolt head is assured before applying torque. Note that an alignment mark is provided on the coded bolt head and adaptor tool to aid refitting. The spline drive extension and the coded adaptor tool are stowed in the vehicle tool pouch, and should remain with the car at all times to allow servicing or repairs to be performed.

**GJ.5 - TYRES**

The Pirelli P-Zero tyres fitted to the Evora are suitable for all normal weather conditions. The tyre characteristics include good feedback ('feel') from the road surface to the steering wheel, a high level of steering linearity and response, and little performance degradation with the raised temperatures which may be reached in high speed use.

However, tyre performance will decrease at low ambient temperatures, resulting in reduced levels of grip and an increased susceptibility to damage from impacts. In these conditions, especially where average temperatures are below 0°C (32°F), or where snow may be expected, it is recommended to fit a car set of the recommended winter tyres (see below).



Note that the Pirelli P-Zero tread pattern is asymmetrical, so that when fitting tyres, attention must be paid to the sidewall marking, and the side of the car for which the wheel and tyre is intended. Wear indicators are moulded into the bottom of the tread grooves at intervals around the tyre, indicated by small pointers on the outer tread blocks. The tyres should be replaced before being worn to this minimum legal tread depth.

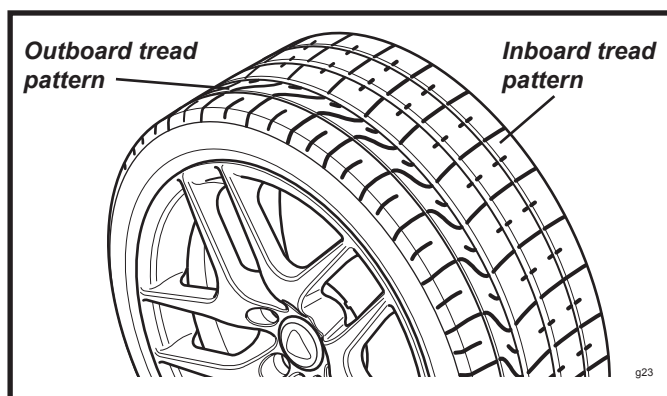

Tyre type		Pirelli P-Zero
Size	- front	225/40 ZR18
	- rear	255/35 ZR19
Pressure (cold) - normal driving conditions		
	- front	2.3 bar (33.5 psi)
	- rear	2.5 bar (36 psi)
	- high loads and/or speed	
	- front	2.8 bar (40.5 psi)
	- rear	3.0 bar (43.5 psi)

## GJ.6 - WINTER TYRES & SNOW CHAINS

If the car is to be used in very cold climates, or driven on snow covered roads, it is recommended to fit a complete vehicle set of winter tyres developed specifically for such conditions. For the Evora, Lotus recommends the use of Yokohama W.drive V-902 winter tyres in sizes specified below.

Wear indicators are moulded into the bottom of the tread grooves at intervals around the tyre, indicated by small pointers on the outer tread blocks. In order that these tyres maintain their design performance on snow covered roads, the minimum tread depth is designated as 4 mm, which is reflected in the height of a secondary set of wear indicators.

Note that the W.drive tread pattern is asymmetrical, so that when fitting tyres, attention must be paid to the sidewall marking, and the side of the car for which the wheel and tyre is intended.

Winter Tyres	- type	Yokohama W.drive V-902
	- size - front	215/40 R18
	- rear	245/35 R19
Pressure (cold) - front		2.3 bar (33.5 lb/in <sup>2</sup> )
	- rear	2.5 bar (36 lb/in <sup>2</sup> )

### WARNING:

- **When winter tyres are fitted, a maximum speed of 118 mph (190 km/h) must be observed.**
- **The tyres are NOT suitable for studding.**

### **Snow Chains**

In extreme weather conditions, Lotus approves the fitment of RUD-matic DISC snow chains (Lotus part number A132G6004F), used only in conjunction with winter tyres (see above) and fitted only on the rear wheels. Close attention should be paid to the fitting and tensioning instructions supplied with the chains. The chains should be removed as soon as road conditions allow.



## GJ.7 - PUNCTURED TYRE EMERGENCY INFLATOR (If fitted)

In order fully to exploit the benefits of light weight, and to maximise stowage space, the Evora has no provision for spare wheel carriage or lifting jack. A temporary puncture sealing facility is provided in the form of an emergency tyre inflator aerosol mounted in a spring clip at the extreme right hand side of the boot. If possible, avoid driving on a deflated tyre, or irreparable damage to the tyre structure may be caused.

When the aerosol is connected to the tyre valve, and the button pressed, a mixture of liquid latex and propellant is injected into the tyre, such that the solidifying latex is forced into the puncture site at the same time as the tyre is inflated, effecting a temporary repair and enabling the car to be driven at low speed to the nearest tyre depot.

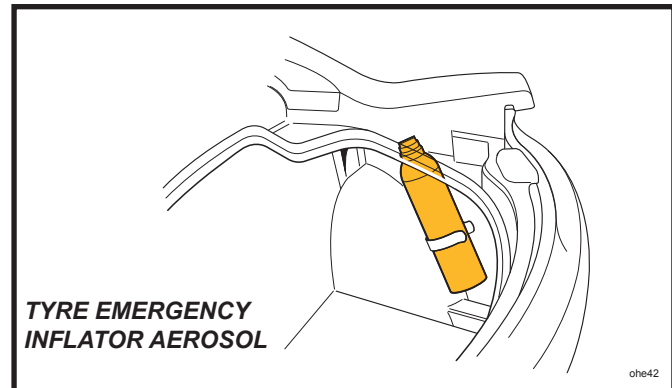

### **WARNING:**

- **Use of the aerosol does not constitute a permanent repair, but is designed to allow the car to be driven to the nearest tyre depot. At the earliest opportunity, the tyre should be professionally repaired or replaced dependent on the severity of the damage.**
- **Until the tyre is repaired or replaced, the car should be driven only in a moderate manner, not exceeding 30 mph (45 km/h).**
- **Do not use the aerosol for large holes or repairs, or when the tyre sidewall has been damaged, or if the tyre has been displaced from the rim.**
- **For safety reasons, the aerosol should be carried at all times in the designated stowage position. Never carry in the passenger compartment.**

As soon as a puncture is suspected, the car should be stopped at the first safe opportunity. Continued driving on a deflated tyre will cause irreparable damage to the tyre.

*Directions for use of the aerosol:* Before using, carefully read all the instructions on the canister, or on any literature accompanying the product. The following instructions apply to the use of Holts Tyreweld:

1. Remove the object causing the puncture, and position the wheel with the puncture site lowermost. Deflate tyre fully.
2. Shake the can vigorously. In cold conditions, warm the can using the car's heater outlets, or by body warmth.
3. Screw the aerosol tube onto the tyre valve, remove the cap, hold the can upright and press the button until the tyre is firmly inflated.
4. Immediately drive for 6 - 12 miles (10 - 20 km) (or to the tyre depot if nearer) in a moderate manner and not exceeding 30 mph (45 km/h), to allow the sealant to spread. Then check and adjust the tyre pressure.
5. Have the tyre professionally repaired or replaced at the earliest opportunity, and until such time, limit speed to 30 mph (45 km/h) with a moderate driving manner. Note that some tyre repairers may make an additional charge for cleaning the sealant off the tyre before repair, and that any subsequent repairs may not be guaranteed. Be aware that the electronic pressure sensor mounted inside the tyre and integral with the tyre valve, could be obstructed by the sealant, and should be renewed.
6. Renew the puncture repair aerosol.





STEERING

SECTION HI

	<u>Sub-Section</u>	<u>Page</u>
General Description	HI.1	2
Power Steering Rack Operation	HI.2	3
PAS Fluid Check & Refill Procedure	HI.3	6
Steering Wheel	HI.4	6
Steering Column Assembly	HI.5	7
Intermediate Column	HI.4	8
Track Rod Ends & Rack Gaiters	HI.5	9
Front Wheel Alignment & Rack Gaiters	HI.5	8
Rack & Pinion Assembly Removal/Replacement	HI.6	10
PAS Pump & Testing Procedure	HI.7	11



**Column and Rack Assembly**

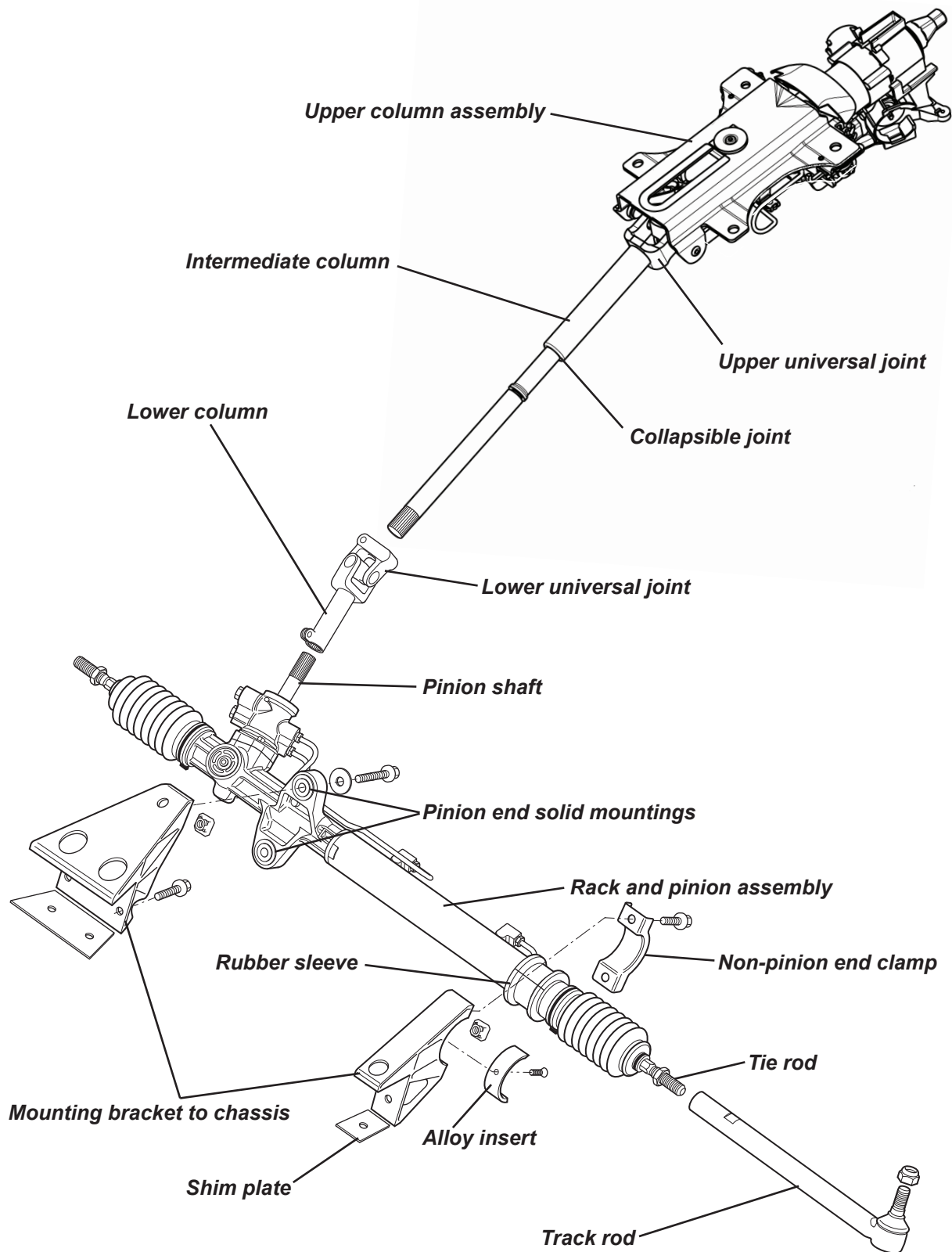



### HI.1 - GENERAL DESCRIPTION

The power assisted steering system of the Evora comprises a column assembly, adjustable for height and reach, connected via two universal joints and an intermediate shaft, to a rack and pinion steering gear mounted on the chassis front subframe ahead of the front axle line. Power assistance is provided by a hydraulic pump mounted on the LH side of the engine, driven by the auxiliary belt, with a hydraulic reservoir located at the RH side of the engine bay. The pipes connecting the pump and reservoir to the rack assembly, are routed along the outside of the RH main chassis rail, within the body sill.

The column assembly comprises three sections, upper, intermediate and lower, articulated with two universal joints. The upper section is bolted to the chassis scuttle structure and provides for a steering wheel reach variation of 40 mm, and a vertical adjustment range of 43 mm. A clamping lever is positioned below the column, which is lowered to allow an adjustment to be made, and should be pushed fully upwards to clamp the setting before the car is driven. The intermediate column, like the upper, is telescopic, and in this instance allows for length compression of the column in the event of rack displacement in a vehicle collision. The short lower column connects to the steering rack pinion shaft.

The steering rack assembly consists of an alloy pinion housing/valve body, and a steel tube through which the rack is guided. The pinion housing features two lugs with solid alloy inserts, which bolt to an extruded alloy bracket, itself bolted to the subframe. The non-pinion end of the rack tube is clamped via a split rubber sleeve around the rack housing, to a second extruded bracket, again bolted to the subframe. Short ball jointed tie-rods from each end of the rack connect via length adjustable track rods, to forward facing steering arms integral with the forged steel front hub carriers, with outer pivot points positioned laterally to provide a 32% Ackermann effect, and vertically for a toe-out on bump characteristic. The rack and pinion assembly is geared to provide 47.4mm rack travel for one steering wheel revolution, with 2.86 turns needed from lock to lock.

Steering power assistance is sourced from a belt driven, vane type hydraulic pump, mounted at the right hand front of the engine. Pipework to and from the power rack assembly is routed within the RH body sill, with a fluid reservoir mounted at the RH rear of the engine bay. Some cars destined for hot climates are equipped with a befinned oil pipe cooler loop incorporated into the return line from rack to reservoir, and mounted ahead of, and at the base of the engine coolant radiator.

### HI.2 - POWER STEERING RACK OPERATION

The steering rack assembly comprises the following major components:

- a round section steel bar with rack teeth machined at one end.
- an alloy pinion housing to support and contain the pinion shaft and hydraulic valve body assembly, and also support the pinion end of the rack bar.
- a steel tube pressed into the pinion housing to support the non-pinion end of the rack bar, and provide an hydraulic cylinder for power operation of the rack.

The rack housing contains two seals, between which a piston on the rack bar operates to form two hydraulic cylinders, each of which is linked to the valve body by a steel pipe. By using a pumped oil supply and a mechanism for creating a pressure differential between the two cylinders, a force can be applied to the piston and rack bar to provide steering assistance in either direction.

The valve body, which is integral with the pinion gear housing, contains three main elements:

- an input shaft/valve rotor connected to the steering column;
- a valve sleeve fixed to the pinion gear.
- a torsion bar connecting the two;

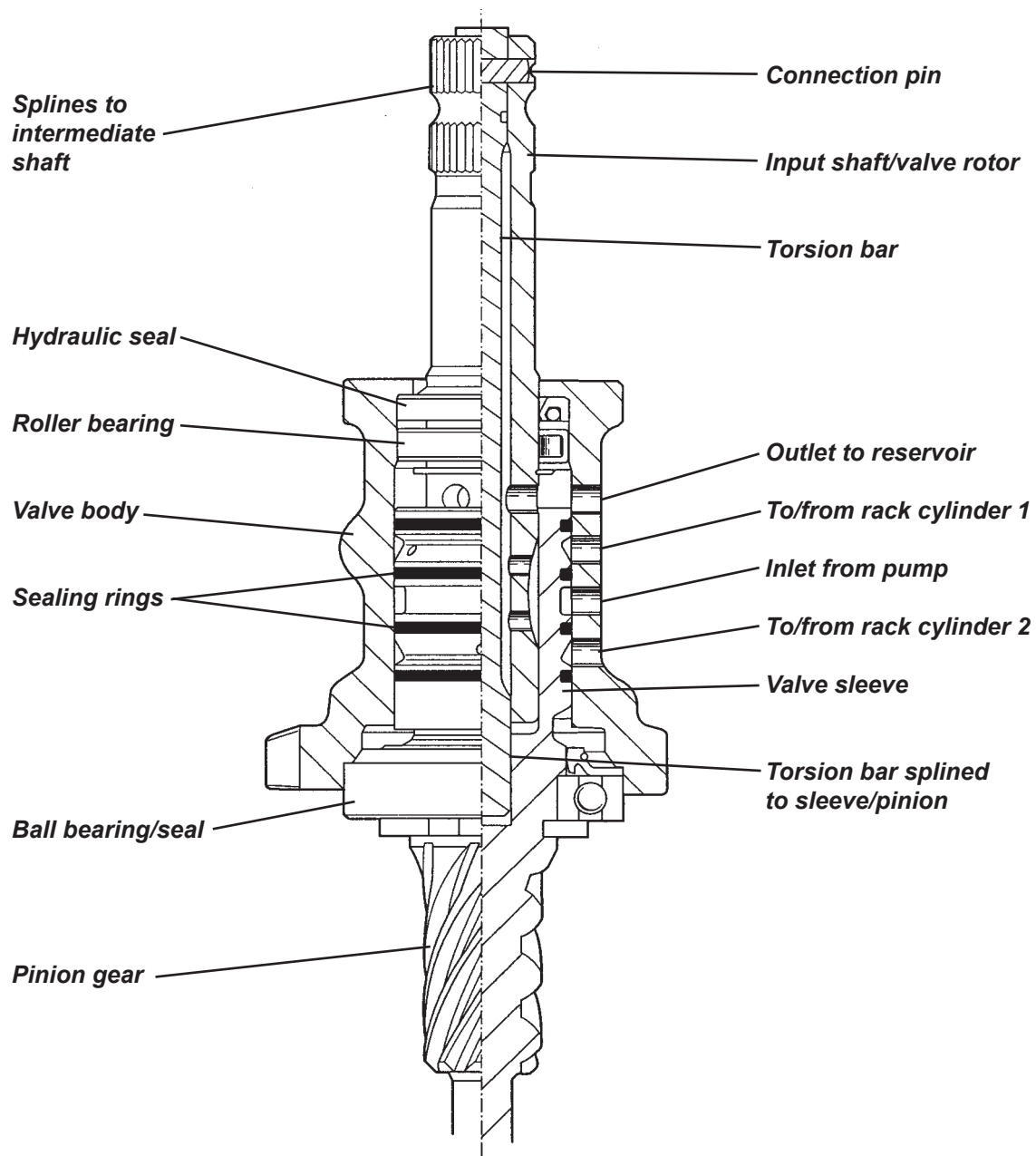

h61

The steering column is clamped to splines on the top end of the rack input shaft, the lower end of which is machined to form a valve rotor, turning within the valve sleeve. The valve sleeve is fixed to the pinion gear and contains hydraulic ports which are controlled by the position of the rotor relative to the sleeve. The rotor and sleeve are connected by the torsion bar, the top end of which is secured inside the top end of the hollow input shaft (rotor), and the bottom end splined into the pinion gear (sleeve). The degree of twist of the torsion bar is determined by the force applied at the steering wheel, and is proportional to the loading at the front tyres. These forces tend to be highest when manoeuvring at low speed (e.g. parking) and result in the greatest angular displacement between valve rotor and sleeve.

The valve body incorporates 4 ports:

- inlet from the engine driven pump;
- outlet (return) to the reservoir;
- connection to the right hand rack cylinder;
- connection to the left hand rack cylinder.



Power Steering Schematic (RHD shown)

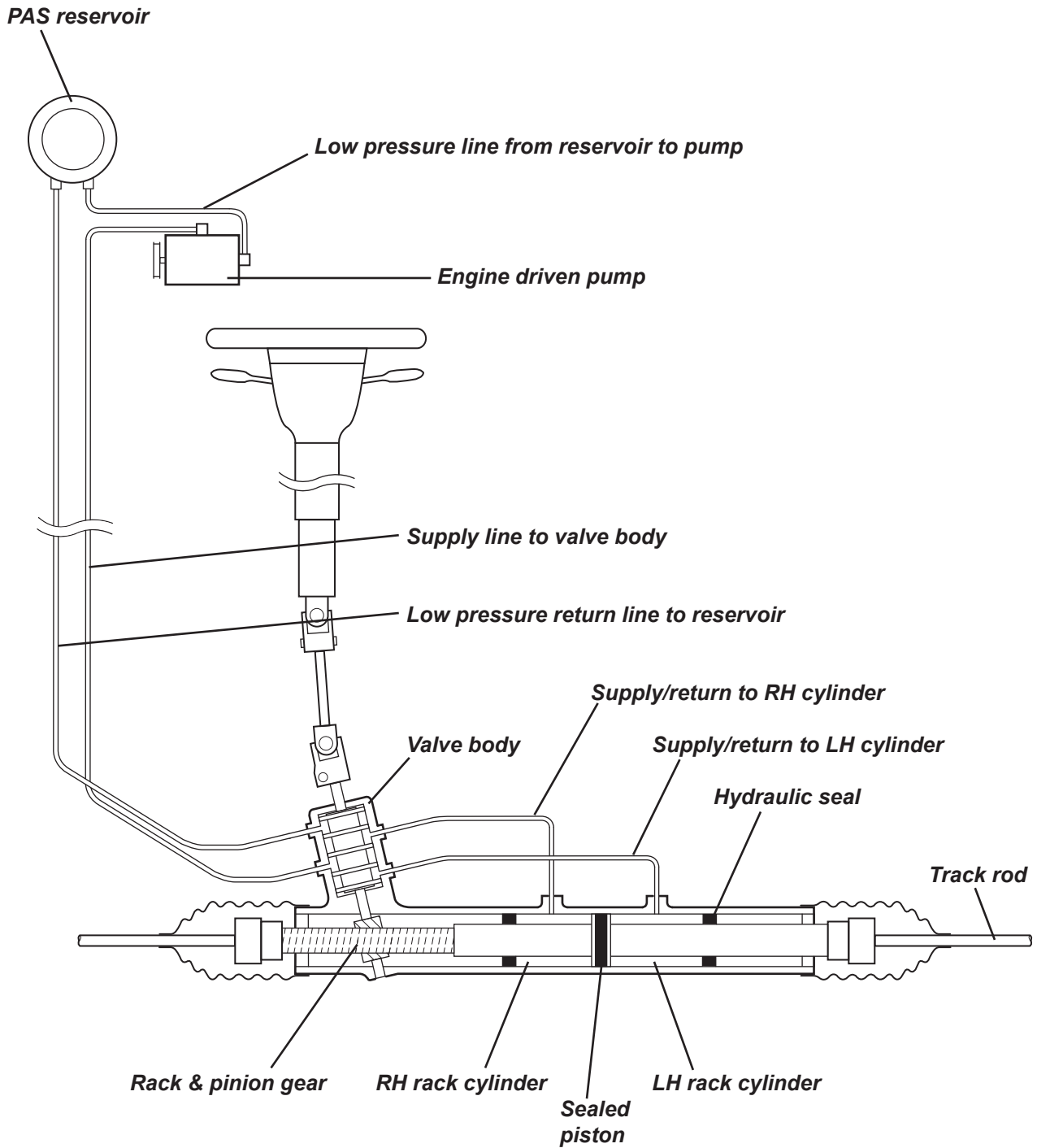

h62



The schematic diagram below shows the principle of valve control, although in practice, six pockets are machined in the rotor and sleeve, and the valve system is repeated three times. The valve sleeve is provided with four sealing rings in order to divide the inlet and outlet feeds and connect with ports in the valve body, whilst allowing 360° rotation of the valve assembly.

**RHD steering being turned to left**

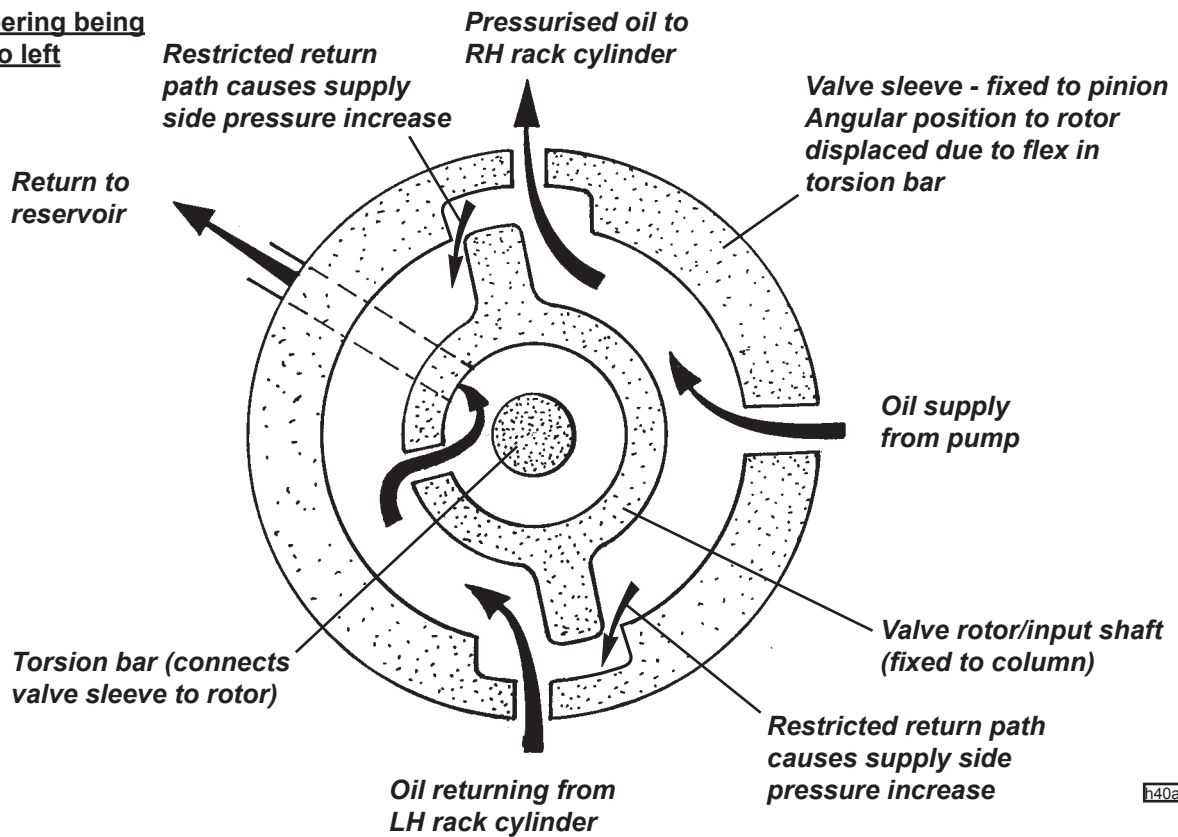

The engine driven pump supplies oil at a controlled rate. A progressive restriction of this oil flow will cause the pressure to increase whilst the flow rate is maintained. Eventually, when the flow is completely restricted, the pressure will rise to the relief valve setting in the pump, causing oil to flow through the relief valve and re-circulate within the pump.

The hydraulic valve in the steering gear provides this restriction according to the force applied at the steering wheel and the loading on the front tyres. The valve is configured as 'open centre' such that when no torque is applied to the steering wheel, there is minimal restriction to the oil supply, resulting in low oil pressure and the freedom to flow to both rack cylinders and through the outlet port back to the reservoir. The pressure differential across the rack piston is zero.

When the steering is turned to the left against some resistance, the input shaft/rotor transmits the motion to the pinion gear/valve sleeve via the torsion bar, which twists in proportion to the effort applied at the wheel and the resistance at the tyres. Effort is high typically at slow vehicle speeds, or when parking. When the bar twists, the angular position of the rotor relative to the valve sleeve alters, with the result that the ports to cylinder 1 become biased towards the pressurised supply, and the ports to cylinder 2 biased to the reservoir return port at low pressure. Hence a pressure differential is created within the rack housing, with higher pressure in cylinder 1 applying a force to the steering rack piston to assist the turn.

If the steering is turned hard against resistance, or the lock stop, the valve will completely close off the return path and cause delivery pressure from the pump to rise until the pressure relief valve in the pump opens; maximum assistance has been reached.

The ultimate degree to which the torsion bar is permitted to twist, is limited by mechanical contact between the input shaft and the pinion gear. This mechanism prevents the torsion bar being over stressed, defines the maximum level of assistance, and provides a safety back up in case of torsion bar failure; steering control would be retained, albeit with a small amount of lost motion.



### HI.3 - PAS FLUID CHECK & REFILL PROCEDURE

Recommended fluid: PAS or Automatic Transmission Fluid meeting Dexron III  
Capacity: 1.5 litre

#### **Fluid Level Check**

The PAS fluid reservoir is located at the right hand rear corner of the engine bay with the fluid level visible through the translucent material of the reservoir. The level of fluid will rise as the oil temperature warms during normal operation, and the best time to check the level (part of each routine service) is with the engine warm, immediately after a run. With a warm engine, the level should be close to the 'MAX' mark, and if cold, close to the 'MIN'. Note that there are two sets of marks on the reservoir, with hot markings on the outboard side, and cold marks in the inboard side, the hot marks being at a slightly higher level. The fluid level will also drop slightly when the engine is running.

Under normal circumstances, the PAS fluid should not require any topping up, and a drop in level is likely to be an indication of a leak.

If topping up is required, the air outlet grille at the RH rear corner of the engine bay must first be removed by releasing its two retaining screws. The reservoir cap may then be removed and a suitable funnel used to aid the addition of an approved fluid. Do not overfill. Replace the cap securely, and refit the grille.

#### **Fluid Change & Bleeding**

In the normal course of operation, it is not necessary to change the hydraulic fluid, only to check the level. If, however, the system becomes contaminated with dirt or other fluids, all pipework connections should be released and fluid expelled using low pressure air. Dispel fluid from the rack mechanism by turning the steering to each full lock. Dispel fluid from the pump by cranking the engine for a few moments with ignition disabled.

After draining the fluid, or after the loss of fluid during the course of repairs or hydraulic system disconnection;

- Fill the reservoir with an approved fluid.
- Raise the front of the car and turn the steering wheel slowly from lock to lock several times. Top up fluid level if necessary.
- Lower the car, start the engine and idle for a few minutes, before turning the steering to full lock and holding for 3 seconds, then repeating for the opposite lock. Repeat this sequence several times.
- Stop the engine and check the reservoir level.
- Any foaming or emulsification of the oil is an indication of air in the system. Repeat the above procedure. If symptoms persist, check for air/fluid leaks.

### HI.4 - STEERING WHEEL

The alloy three spoke steering wheel features a flattened lower section to facilitate driver access, a leather trimmed rim, buttons for the cruise control (if fitted) and an airbag module which also serves as a press pad to operate the horns. The electrical supply for the steering wheel mounted equipment utilises a rotary coil assembly surrounding the column.

The wheel comprises a cast magnesium rim and spokes, to which is bolted a machined alloy hub, with a screw fixed alloy pressing to carry, via double sided tape, the cruise control buttons and/or trim.

#### **To Remove Steering Wheel**

**WARNING: The following procedures must be followed in the order listed to temporarily disable the airbag system whilst working in the immediate vicinity of an airbag. Failure to follow this procedure could cause unintended airbag deployment, resulting in personal injury and unnecessary airbag system repairs.**

- i) Turn off the ignition.
- ii) Before disconnecting the battery, use the Lotus TechCentre to read any stored trouble codes.
- iii) Disconnect the negative (earth) lead from the battery and tape back to ensure that no contact with the battery negative terminal can be made.
- iv) Wait for 30 seconds.



- v) Unclip the top part of the column shroud, then remove the lower part after releasing the three retaining screws.
  - vi) Locate and unplug the airbag harness from the rotary connector. Note that the connector socket is fitted with 'shorting bars' which automatically interconnect the high and low terminals of the airbag to prevent uncheduled deployment caused by a voltage differential.
1. On the reverse side of the steering wheel, release the two Torx head screws, accessible via holes in the plastic shroud around the steering wheel hub.
  2. Withdraw the airbag module and disconnect the two airbag harness connectors and the two horn leads.

**WARNING: When carrying a live airbag module, make sure the bag and trim cover are pointed away from you. In case of an accidental deployment, the bag will then deploy with minimal chance of injury. When placing a live airbag module on a bench or other surface, always face the bag and trim cover upwards, away from the surface. This is necessary so that a free space is provided to allow the airbag to expand in the unlikely event of accidental deployment.**

3. Unplug the cruise control harness and the airbag/horn harness from the rotary connector.
4. Ensure the wheels are pointing straight ahead, match mark the wheel to the column, and remove the steering wheel retaining bolt. Note that the wheel is located on a steep angle hexagonal taper on the column.  
**CAUTION: If excessive force is applied to either the steering wheel or column, the break-out inserts securing the column to the fascia bracket may be disturbed, necessitating replacement of the complete column. If necessary, use an appropriate puller.**
5. If necessary, remove the cruise control switches and trim by carefully prising away from the double sided tape fixing. Remove the 4 screws to release the cover from the wheel reverse side.
6. Refit in reverse order to removal, but before fitting the steering wheel, it is essential to centralise the rotary connector, or the unit will be broken when lock is applied. Turn the connector fully clockwise until it tightens, and then turn back just over two turns until the red marker appears in the square window. Note that this instruction is printed on the rotary connector. Ensure the road wheels are pointing straight ahead and fit the steering wheel with the match marks aligned. Tighten the steering wheel retaining bolt to 50 Nm. When fitting the jump harness for the cruise controls, ensure the cable is routed through the channel provided in the steering wheel carrier.
7. After re-assembly, check that the airbag tell tale lights for a few seconds with ignition, and then goes out.

### Steering Wheel Alignment

Ideally, the steering wheel should align in the straight running position, with the steering rack centralised and with equal track rod lengths. In practice, a minor compromise to track rod lengths may have to be made. To arrive at the optimum setting, proceed as follows:

Note that only one splined joint in the steering system allows a choice of position, this being the connection of the lower column to the rack pinion shaft.

1. Set the front wheel alignment to specification with equal track rod lengths (see sub-section CK.2).
2. With the wheels pointing straight ahead, fit the steering wheel on the column hexagonal taper in the straight ahead position, and secure with the retaining bolt, torque tightening to 50 Nm.
3. Road test the car and mark the actual 'straight ahead' position of the wheel which should deviate from the ideal position by less than 5°. If more than this, the lower column should be released from the rack pinion shaft and re-positioned on the splines before repeating the procedure.
4. Final steering wheel alignment is achieved by asymmetric adjustment of the track rods, retaining the overall toe-out setting.





## HI.5 - STEERING COLUMN ASSEMBLY

The steering column assembly includes a two-piece upper inner column, consisting of two tubes ('A' upper; 'B' lower) with a sliding splined joint to accommodate reach adjustment, articulated via a universal joint to a similarly constructed two-piece ('C' upper; 'D' lower) intermediate column, which allows for telescoping compression in the event of vehicle collision. A third, lower column ('E'), is articulated from the intermediate shaft via a second universal joint, and is splined directly to the rack pinion shaft.

The upper column assembly comprises a steel mounting bracket from which is hung a pivoted alloy carrier for the ball bearing race supporting the lower end (B) of the two-piece upper column. The upper (steering wheel) end of the column (A) is supported in a steel tube outer column fitted with synthetic plain bushes. The outer column is fixed to the column mounting bracket via a cam operated clamp, which allows vertical and axial movement of the upper outer/inner column assembly, the inner column (A) being free to slide over the splines on the lower column (B). The upper end of the assembly incorporates an alloy housing to accommodate the steering lock/ignition switch and top bearing.

The lower end of the upper column assembly is articulated via a universal joint to the intermediate column, which itself comprises an upper tube (C) splined over a lower shaft (D) to provide a telescopic length variation of approx. 50mm. This feature allows for steering column length compression in the event of vehicle collision in order to reduce the potential for occupant injury. For a similar purpose, the mounting bracket for the upper column assembly is constructed in two parts, the forward part being rigidly secured to the scuttle beam, whereas the rearward part is retained to the beam only by open ended slots equipped with special 'break out' inserts. In the event of a heavy forward load being applied to the steering wheel, such as may occur in an accident, the rearward part of the bracket complete with upper column assembly is able to break free from the scuttle, pushing the column (B) through the lower bearing and collapsing the intermediate column. After any such occurrence, the complete steering column assembly should be replaced.

If, in any circumstances, an abnormal load is applied to the steering wheel or upper column assembly, the column shrouds should be removed and the 'break out' inserts carefully checked.

### To Remove Steering Column Assembly

**WARNING: The driver's airbag is housed in the hub of the steering wheel. Precautions need to be taken for personal safety when working with airbags and associated componentry. Do not attempt to remove the airbag, steering wheel or column without first referring to section WF.**

1. Remove the steering wheel (see sub-section HI.4).
2. Remove the rotary connector (see sub-section WF.10).
3. Remove the fascia dash panel (see sub-section VE.7).
4. Release all wiring harness restraints from the column.
5. If necessary, remove the steering lock/ignition key barrel: Turn the key to position 'I', depress the spring pin accessible via a hole in the rear of the housing, and withdraw the lock barrel.

**CAUTION: Once the lock barrel has been removed from the column, it is essential NOT to turn the lock mechanism. Failure to heed this advice will result in the mechanism being irreparably displaced, and a complete new column assembly being required.**

When re-fitting a lock barrel, note that the key must be positioned at 'I' before the locating pin may be depressed to allow insertion. Ensure the pin is correctly engaged in the housing hole.

6. If necessary, remove the ignition switch: Depress the two retaining barbs, and withdraw. When re-fitting, the position of the ignition switch must be adjusted to match that of the lock spindle.

**CAUTION: If the lock barrel is removed, on no account should the position of the lock mechanism be disturbed, or irreparable displacement of the mechanism may occur, necessitating replacement of the complete column assembly.**



7. Disconnect the steering angle sensor, and release its mounting bracket from the scuttle. Release the clamp securing the sensor to the column.
8. Remove the front undertray and remove the pinch bolt securing the lower universal joint to the rack pinion shaft and match mark the joint. Release the gaiter from the chassis aperture.
9. The column must be withdrawn complete with the two extruded alloy mounting brackets securing it to the scuttle beam. For each of these two brackets, release the single front fixing into the top surface of the scuttle beam, and the two rear fixings into the vertical face; all use threaded inserts in the chassis.
10. Withdraw the column assembly from the pinion shaft and through the fascia aperture.

### To Refit Steering Column Assembly

New steering column assemblies are supplied without a steering lock barrel or ignition switch to allow transfer of existing components. A plastic sleeve is fitted in the lock barrel bore for transit purposes.

**CAUTION: Do not attempt to remove the plastic sleeve without following the procedure below. Failure to heed this advice may result in the lock mechanism being irreparably displaced, and a complete new column assembly being required.**

- a) With the plastic sleeve still in place, and the ignition switch removed, use the lock spindle and the features on the mechanism plate which interfaces with the lock barrel, to turn the lock mechanism to position 1 (to match the features of the key lock barrel at this position). At this position, the column is unlocked.
- b) As a precaution, maintain a pulling action on the lock spindle from now until the lock barrel is securely installed.
- c) Turn the plastic insert a quarter turn clockwise and withdraw. With the key turned to position '1', insert the lock barrel into the lock housing and ensure that the spring loaded pin is engaged in the housing locating hole.
- d) The lock spindle may now be released.

Continue the assembly procedure in reverse to removal with the following notes:

- Slide the steering angle sensor and toe board gaiter over the intermediate column during installation.
- Torque tighten fixings as follows:
  - Column 'break out' fixings; 24 Nm
  - Column to forward fixing holes in extruded scuttle brackets; 24 Nm
  - Extruded brackets to scuttle; 24 Nm
  - Lower u/j pinch bolts; 25 Nm

## HI.5 - TRACK ROD ENDS & RACK GAITERS

### Front Wheel Alignment

Alignment is measured either by the angle the front wheels make with the vehicle's longitudinal axis, or the difference in dimension between the wheel rim to wheel rim measurement at the front and rear of the wheel at hub centre height. The wheels are said to 'toe-in' when the wheel paths converge ahead of the vehicle, and 'toe-out' when they diverge. Wheel alignment is designed to vary with both steering angle (Ackermann; to minimise low speed, tight turn tyre scrub) and suspension travel (bump steer; to provide consistent handling) and should be measured only 'straight ahead' at the specified mid-laden ride height.

Provision is made for the adjustment of front wheel alignment at the joint between the track rods, which are ball jointed to the outboard ends of the steering rack, and the outer ball joints ('track rod ends') which connect to the steering arms on the hub carriers. In this application, the track rod ends are extended to form the major part of the track rods.

The mid-laden ride height and alignment specification is detailed in sub-section CK.2.



## *Illustration of track rod adjustment*

Note that in order to preserve the required bump steer characteristic and steering symmetry, the effective length of each track rod must remain equal; compare dimensions and equalise if necessary before subsequently adjusting each track rod by a similar amount:

- Slacken the rack gaiter outboard clips.
- Hold the track rod using the flats provided, and slacken the locknut. Repeat for the opposite side.
- Turn each track rod a similar amount. As a guide, turning both track rods by one quarter of a turn will alter overall toe-out by approx. 2.0 mm.
- When adjustment is correct, hold each track rod and tighten the locknuts to 45 Nm. Tighten the rack gaiter clips.

**CAUTION:** When slackening or tightening the track rod locknuts, it is important that the torque reaction is resisted using the track rod flats, and that the ball joint itself is not allowed to be stressed.

### **Track Rod Ends**

The track rod end ball joints are sealed for life and maintenance free. If replacement is required;

- Remove the ball pin nut and use a ball joint splitter tool to separate the joint from the steering arm.
- Unscrew the track rod from the steering rack tie rod, using the locknut as a refitment position guide.
- On re-assembly, tighten the ball joint to steering arm nut to 45 Nm, and set the front wheel alignment as detailed in sub-section CK.2.

### **Steering Rack Gaiters**

The convoluted gaiters sealing each end of the steering rack housing to the tie rods, should be inspected at service intervals and replaced immediately if found to be torn, cracked or otherwise damaged. The ingress of dirt or water into the rack housing will cause rapid deterioration of the track rod inner ball joints, rack end bushes and rack and pinion mechanism, requiring replacement of the complete steering gear.

To replace a gaiter, remove the track rod (see above), release the gaiter clips, and slide the gaiter off the housing and tie rod. Check for consequent damage or wear and replace the steering gear assembly if necessary. Fit the new gaiter into position, and secure with new retaining clips.

## HI.6 - RACK & PINION ASSEMBLY REMOVAL/REPLACEMENT

The steering rack assembly consists of an alloy pinion housing/valve body, and a steel tube through which the rack is guided. The pinion housing features two solid bushed lugs, which bolt to an extruded alloy bracket, itself secured to the subframe with four bolts threading into a tapping plate. The non-pinion end is secured by a 2-bolt clamp and rubber sleeve around the steel tube to a second extruded bracket, secured with two bolts. Short ball jointed tie-rods from each end of the rack connect, via extended 'track rod ends' to forward facing steering arms integral with the forged steel front hub carriers.

Note that the only approved repairs or adjustments to the steering rack assembly are the replacement of the track rod ends, rack housing gaiters, and the pipes connecting the pinion housing to the rack body.



### To Remove/Replace Steering Rack Assembly

The steering rack may be removed from the front subframe after first removing the front anti-roll bar with its mounting brackets.

1. Remove both front wheels, and the front undertray.
2. Release the anti-roll bar from the drop link at each side.
3. At each side, remove the six screws securing the extruded alloy mounting plate to which the ARB clamp is fixed. Captive threaded inserts are used in the subframe. Withdraw the anti-roll bar assembly from the car.
4. Remove the nut securing each track rod end to the steering arm, and use a ball joint splitter to separate the joint.
5. Match mark the pinion shaft against the u/j yoke to aid steering wheel alignment on re-assembly, and remove the pinch bolt.
6. Slacken the banjo bolts securing the feed and return pipes to the pinion housing, and collect the draining oil. Removal of the bolts may not be possible at this stage.
7. At each end of the rack housing, remove the two bolts securing the unit to the mounting brackets. Withdraw the pinion shaft from the lower u/j and remove the two banjo bolts as the assembly is withdrawn from below.

### To Re-fit/Replace Steering Rack Assembly

Refit in the reverse order to removal, with the following notes:

- Engage the pinion shaft with the column u/j (match marks aligned) as the housing is positioned. Fit and tighten the u/j pinch bolt to 25 Nm.
- Before securing the rack housing, refit the feed and return pipes to the pinion housing using new or annealed washers. Torque tighten M14 (return) to 18 - 25 Nm; M16 (feed) to 25 - 30 Nm.
- Torque tighten housing fixing bolts (4 off) to 45 Nm.
- Torque tighten track rod end ball pin nuts to 45 Nm.
- Torque tighten the anti-roll bar clamp mounting plate to subframe bolts (8 off) to 24 Nm.
- Torque tighten the anti-roll bar to drop link fixings to 38 Nm.
- Refill the power steering reservoir and bleed the system as detailed in sub-section HI.3
- Check and adjust the front wheel alignment as detailed in sub-section CK.2.

**Note:** If the rack mounting plinths are removed from the front subframe, note that there are shim plates fitted between the plinths and the subframe top surface in order to control the height of the rack and the bump steer characteristic. Shim plates are available in thicknesses of 5, 2 and 1mm, with the standard setting being two 2mm shim plates at each position. Torque tighten the plinth to subframe fixing bolts to 45 Nm.

### HI.7 - PAS PUMP & TESTING PROCEDURE

The vane type, constant displacement hydraulic pump is mounted on the right hand front of the cylinder block, and is driven by the automatically tensioned multi-rib auxiliary belt from the crankshaft pulley. To check for correct functionality, the steering effort may be checked with the engine running and the car stationary:

#### **PAS Pump Test Procedure**

##### *Tools required*

PAS Pressure Test Gauge Kit - use a universal kit, or Toyota part number 09640-10010

1. Remove the rear clamshell (see Sub-Section BV.6).



2. Check auxiliary drive belt condition and fluid level. With engine idling, turn the steering from lock to lock several times to raise fluid temperature and check for foaming or emulsification; if necessary, bleed the system (see Sub-Section HI.3).
3. Remove the banjo bolt connecting the pressure outlet pipe to the PAS pump. Fit the adaptor pipe from the test kit into the pump, and connect the gauge inlet pipe to the adaptor.
4. Connect the outlet pipe on the gauge to the banjo connector using the union adaptor.
5. Open the gauge valve, and bleed the system of air (see above).
6. With the engine idling, turn the steering from lock to lock several times to raise fluid temperature (70 - 80°C).
7. With the engine idling, close the gauge valve and observe the gauge reading - **Do not keep the valve closed for more than 10 seconds**, or excessive oil heating will occur.  
Minimum fluid pressure: 7800 to 8300 kPa (1100 to 1200 psi).
8. With the engine idling, open the gauge valve fully and measure the pressure at engine speeds of 1000 and 3000 rpm.  
Maximum difference: 490 kPa (70 psi).
9. With the engine idling and the gauge valve fully open, turn the steering to full lock and measure the fluid pressure. Repeat for the opposite lock - **Do not keep on full lock for more than 10 seconds**, or excessive oil heating will occur.  
Minimum fluid pressure: 7800 to 8300 kPa (1100 to 1200 psi).
10. Disconnect the gauge pipes and refit the banjo union to the pump. Bleed the system of air (see above).

### HI.8 - PAS PUMP REMOVAL & INSPECTION

The vane type, constant displacement hydraulic pump is mounted on the right hand front of the cylinder block, and is driven by the automatically tensioned multi-rib auxiliary belt from the crankshaft pulley. The pump is secured to the engine by two bolts, access to which requires the removal of the rear clamshell.

1. Remove the rear clamshell (see Sub-Section BV.6).
2. Use a syringe to empty the PAS reservoir of oil and reduce potential spillage.
3. Using a 14mm hexagonal socket, turn the auxiliary belt tensioner counterclockwise to relieve tension on the belt, and insert a 5mm rod through the tensioner hole to secure in that position. Mark the direction of rotation on the belt before unhooking from the PAS pump pulley.
4. Disconnect the reservoir hose from the pump, and plug both hose and pump port.
5. Disconnect the high pressure feed pipe from the pump, and plug both pipe and pump port.
6. Disconnect the harness from the PAS pump pressure switch.
7. The pump is secured to the engine by two bolts, accessible between the spokes of the pulley. Remove the lower bolt. Unscrew the upper bolt from its threaded boss, but leave in position whilst withdrawing the pump from the slotted upper lug.
8. *Flow Control Valve:*
  - Remove the pressure port union and 'O' ring.
  - Remove the flow control valve and compression spring.



- With the pump port axis vertical, check that the valve (lubricated with PAS fluid) falls smoothly into the port. If any stickiness is apparent, replace the pump.
  - Check the valve for leakage: Close off one of the ports in the side of the valve, and apply 450 kPa (65 psi) of compressed air to the opposite port. No leakage from either end of the valve should be detected.
  - Measure the free length of the flow control valve spring with a vernier caliper: Minimum = 29.2 mm
  - Coat the valve with PAS fluid and instal with its spring. Fit a new 'O' ring on the pressure port union, lubricate, instal and tighten to 69 Nm (51 lbf.ft).
9. *Vane Pump Mechanism:*
- Remove the 4 bolts securing the pump rear housing, and withdraw the housing.
  - Remove the snap ring from the pump shaft and withdraw the pulley and shaft assembly.
  - Remove the pump rotor with its 10 vanes, followed by the cam ring and pump front plate.
  - Pull out the shaft oil seal from the front of the housing, and press a new seal into position.
  - Measure the thickness of each rotor vane: Specification = 1.405 - 1.411 mm
  - Measure the side clearance between each vane and its rotor slot: Max. clearance = 0.03 mm
  - Measure the pump shaft diameter and housing bush diameter and determine the oil clearance: Max. clearance = 0.07 mm
  - Refit the shaft and pulley assembly, taking great care not to damage the oil seal.
  - Fit new 'O' rings to the housing and front plate and lubricate with PAS fluid, before inserting the plate into the housing with the notch on the rear side rim aligned with the notch in the housing.
  - Fit the cam ring into the housing with the inscribed mark facing rearwards, and the notch aligned with the notch in the front plate.
  - Fit the vane rotor onto the shaft and lubricate before sliding the 10 vanes into their slots.
  - Retain the rotor by installing a new snap ring into the shaft groove.
  - Fit a new 'O' ring into the groove in the rear cover, and fit the cover to the housing so that the alignment pin engages into the notches in the cam ring, front plate and pump housing. Fit the 4 retaining bolts and tighten to 22 Nm.
  - *Check Preload:* Fit a M10 x 1.25 x 50mm bolt into the pulley end of the shaft, and apply a torque wrench to the bolt. Check pump rotation torque; Max. = 2.8 kgf.cm (2.4 lbf.in).
10. If necessary, fit a new PAS pressure switch with lubricated 'O' ring, and tighten to 21 Nm.
11. Before installing the pump, insert the upper bolt through the top lug on the pump housing. Fit the pump to the engine and secure with the upper and lower bolts. Tighten both fixings to 43 Nm (32 lbf.ft).
12. Plug in pressure switch connector. Fit banjo bolt with two new washers and connect high pressure pipe to outlet union. Tighten to 50 Nm (37 lbf.ft). Connect the reservoir hose to the pump spigot and secure the clamp.
13. Refit the auxiliary drive belt to all pulleys, ensuring that the belt ribs are correlty located on each drive pulley. Rotate the tensioner counterclockwise to relieve tension, and remove the tensioner locking pin.
14. Refill and bleed the PAS system (see above), and check for leaks.
15. Refit rear clamshell (see sub-section BV.6).

**BRAKING SYSTEM****SECTION JL**

	<u>Sub-Section</u>	<u>Page</u>
General Description	JL.1	3
Tell Tale Lamps	JL.2	4
Brake Fluid Check & Change	JL.3	4
Brake Pad Replacement (front & rear)	JL.4	5
Parking Brake Mechanism	JL.5	7
Brake Discs	JL.6	8
Brake Callipers	JL.7	9
Brake Master Cylinder	JL.8	9
Vacuum Servo Unit	JL.9	10
Pedal Box	JL.10	12
ABS Theory of Operation	JL.11	13
ABS Electro-Hydraulic Unit	JL.12	20
Wheel Speed Sensors	JL.13	21
Data Link Connector (DLC)	JL.14	21
Special Tools	JL.15	21
Lotus TechCentre Checking Procedures	JL.16	22



GENERAL LAYOUT

TBA



**JL.1 - GENERAL DESCRIPTION**

The braking system of the Lotus Evora comprises a four piston calliper and brake disc at each wheel operated by a tandem master cylinder with dual diaphragm vacuum servo power assistance. The dual hydraulic circuit is divided front/rear and modulated by a Kelsey-Hayes microprocessor based anti-lock system. A cable actuated parking brake uses brake shoes operating in drums incorporated into the rear discs.

The brake callipers are supplied by A.P. Racing, and feature lightweight alloy bodies housing four pistons in opposed pairs. The castings for the front and rear callipers are common, but are machined differently to accommodate the differing piston diameters. In the front callipers, the leading pistons are 38.2 mm diameter, and the trailing pistons 41.3 mm. The rear callipers house 38.2 mm leading pistons and 36.0 mm trailing. Each calliper is marked on its inner, inboard face, alongside the pad aperture, with its designated fitting position; 'RF' representing Right hand Front, with others marked as LF, RR, and LR. Each calliper is secured to its hub carrier by two bolts disposed in a plane perpendicular to the disc axis, with the front callipers mounted behind the axle line, and the rear callipers ahead of the axle.

The front cast iron discs are 350 mm diameter, 32 mm thick, with optional cross-drilling to enhance pad cleaning, and include internal curved vanes to draw cooling air from the centre to the periphery, with the vanes curving backwards in relation to the normal direction of rotation. The rear cast iron discs include similar features, but are 332 mm diameter and 26 mm thick, and incorporate integral 185 mm diameter drums for the parking brake shoes. Each disc is sandwiched between the road wheel and hub, and is retained for convenience by a single countersunk screw.

The Continental Teves tandem master cylinder incorporates a front section to supply both front brakes, and a rear section to supply the rear brakes. A translucent fluid reservoir is mounted on a bracket above the master cylinder, and is divided into front and rear chambers separated by a weir. The two chambers are connected to the front and rear master cylinder sections by flexible hose, with a third hose connecting the rear brake reservoir chamber to the clutch master cylinder to supply that system's needs. A fluid level sensor in the filler cap will light a fascia tell tale lamp if the level becomes dangerously low.

The parking brake ratchet lever is mounted between the seats in a fabricated steel structure which also houses the gearchange mechanism. The lever activates a primary cable which exits the cabin at the front of the fuel tank bay, and turns through 90° to connect to a balancing yoke at the front of the engine bay. The yoke forms the abutment for the primary outer cable, with the inner cable continuing through a slot in the yoke to link to the RH secondary cable. The opposite end of the yoke connects to the LH secondary cable, with both secondaries leading to their respective rear wheel parking brake backplates. The interaction of the yoke with the three separate cables results in an automatically balanced force being applied to each of the secondary cables.

At the each brake backplate the secondary cable connects to a lever mechanism which provides a balanced expanding force to the lower ends of the parking brake shoes. The upper ends of the shoes pivot against opposite ends of an adjustable length abutment, with access to the toothed adjuster screw available via a hole in the brake backplate.

The parking brake should be applied by pulling up the lever with high effort, and engaging the highest ratchet setting attainable. When parking the car on a slope, the additional precaution should be taken of leaving the transmission in first or reverse gear and steering the wheels towards the kerb.

The braking system is designed to enhance brake performance during high speed driving, with good fade and pad wear characteristics, with the pads offering a higher friction level when heated to normal working temperature than when cold. Required pedal effort will reduce as cold brakes become heated to normal working temperature, and the braking efficiency will increase significantly as new discs or pads become 'bedded in'. After fitting new brake components, maximum braking efficiency will be achieved if, for the first few hundred miles, needless heavy braking is avoided, and the brake pads are allowed to 'bed in' fully before being used to their full potential.

A Bosch Antilock Brake System (ABS) is used to optimise brake performance in extreme conditions and reduce the tendency of any wheel to lock up. Under most conditions, the maximum braking force is provided by a wheel which is rotating at about 90% of road speed. Apart from the likelihood of increasing the stopping distance, a locked wheel provides no steering force, such that with both front wheels locked, movement of the steering wheel has almost no effect on vehicle direction. With the antilock system, even panic braking results in controlled deceleration and the retention of steering response and is especially advantageous when braking on slippery road surfaces and in bad driving conditions. The ABS control system is self monitoring and has the capability of switching itself off if a fault is detected, allowing the base brake system to operate without anti-lock control.



Under normal circumstances, the hydraulic power brake system of the vehicle operates without input from the ABS, with brake pressures governed by the force applied to the brake pedal in conjunction with vacuum servo assistance. The ABS microprocessor receives signals from wheel speed sensors at each of the four wheel hubs, and interprets this data to determine if any wheel is tending to lock up. If imminent lock up is determined, the microprocessor commands solenoid valves in an electro-hydraulic unit to reduce the pressure in that particular brake circuit in order to restore wheel speed to that providing the maximum braking force consistent with continued wheel rotation.

When the ABS is operating, indication to the driver is provided by a 'pulsing' sensation felt at the brake pedal as fluid is pumped between the master cylinder and hydraulic control unit, and also by audible clicking of the relays and switches. These signals indicate to the driver that maximum retardation is being approached, and that driving style should be modified to suit the conditions. The minimum stopping distance is achieved by applying the brakes firmly and steadily, and allowing the ABS to modulate hydraulic pressure. The driver should not attempt to emulate this process by 'pumping' the brake pedal, as modulation at the pedal will treat all four wheel brakes similarly, rather than the individual wheel control governed by the electronics.

During ABS operation, the wheels may appear to lock momentarily as the wheel speed changes rapidly, and some tyre noise (intermittent screeching) may be heard. This noise is normal and will vary with road and tyre conditions. However, a wheel that completely locks and stays locked for more than one or two seconds is not normal, and indicates that the vehicle should be serviced as soon as possible. The ABS cannot operate properly if the base brake system is faulty, and will also be affected by dragging brakes, faulty wheel bearings or other related faults.

The ABS controller constantly monitors the anti-lock system for faults, and lights a fascia tell tale if a problem is detected. Information stored in the computer's memory may be accessed via the Lotus TechCentre in order to facilitate diagnosis of system faults (see later).

## JL.2 - TELL TALE LAMPS

Two tell tale lamps are provided in the instrument cluster to warn of problems in the brake system.

### **Brakes Tell Tale** (ⓘ)

As a bulb check function, this tell tale will glow red for about 3 seconds after ignition switch on, and then go out unless one of the following conditions applies:

- i) The parking brake is applied.
- ii) The brake fluid level in the master cylinder reservoir is low.

Under normal circumstances, the tell tale should light when the ignition is switched on, and go out when the parking brake is released. If the lamp stays on, or comes on whilst driving, the car should be stopped immediately, as this may be an indication of low brake fluid level caused by a hydraulic leak. A button on the reservoir cap allows the tell tale circuit to be tested.

### **ABS Tell Tale** (ABS)

The ABS tell tale warns the driver of problems in the anti-lock system. The lamp should light for about 3 seconds following ignition switch on, and then go out. If the lamp remains lit, or comes on whilst driving, a fault in the ABS is indicated. The base brake system will continue to operate normally, but without ABS regulation. The car can be driven but should be checked and repaired at the earliest opportunity.

## JL.3 - BRAKE FLUID CHECK & CHANGE

Before checking the brake fluid level, ensure that the car is parked on a level surface, and open the front body access panel. The level of fluid in the reservoir may be inspected without disturbing the filler cap, and should be level with the top of the 'MAX' mark moulded on the translucent reservoir body. The level will fall progressively as the brake pads wear in service, and should be checked at each service interval. A sensor incorporated into the filler cap will light a tell tale lamp in the instrument cluster if the level drops significantly.

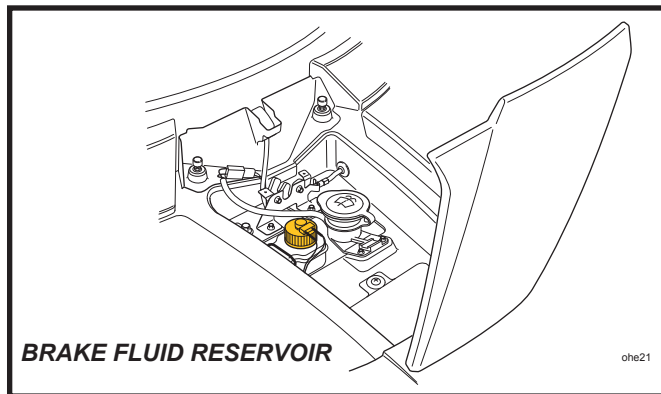

**Non-mineral type brake fluid symbol  
(yellow & black)**



j146

As a bulb check, the tell tale should light for about 3 seconds when the ignition is first turned on, but may also be tested by pressing the button on the filler cap, which action should light the tell tale with the ignition switched on.

The reservoir is mounted on a bracket fixed to the wiper spindle support, and is connected to the master cylinder by flexible hoses. An internal baffle divides the reservoir into two compartments, with one section supplying the front brake circuit, and a second section supplying the rear brakes in addition to, via another flexible hose, the clutch master cylinder. Service wear of the clutch friction plate will cause fluid to be displaced from the self adjusting clutch slave cylinder, back to the reservoir, and will counteract to some extent the dropping of the level due to brake pad wear.

If the reservoir needs topping up, first clean around the cap to reduce the possibility of contamination before unscrewing the cap; it is not necessary to disconnect the level sensor cables. Take suitable precautions to guard against damage to paintwork caused by brake fluid dripping from the level sensor.

Use only a fresh supply of DOT 4 **non-mineral** type fluid, identified by a yellow and black symbol. Do NOT use DOT 5 silicone fluid, or any fluid which has been exposed to the atmosphere for more than a brief period, or any fluid suspected of being wet, dirty or contaminated. Do not overfill. Replace the filler cap securely.

Some service operations, such as replacing brake pads, will result in the displacement of fluid from the hydraulic circuit back into the reservoir. In order to prevent fluid overflowing from the reservoir, it may be necessary to remove some fluid using a syringe.

## Renewal of Brake Fluid

Brake fluid absorbs water from the atmosphere over a period of time (i.e. is hygroscopic), resulting in a lowering of the boiling point of the fluid, and corrosion of the hydraulic system. For optimum safety and brake performance, the brake fluid should be renewed every twelve months (including clutch release system).

### Brake Bleeding Procedure

If the brake fluid is to be renewed, or an hydraulic component replaced, the system should be bled of air using the following procedure:

1. Using conventional manual techniques, or low air pressure applied to the reservoir, bleed the system from each calliper bleed nipple in turn until no air bubbles can be seen.
2. Connect the Lotus Techcentre to the diagnostic link, select ABS and follow the brake bleeding instructions. Whilst this automatic process is taking place (with all 4 calliper nipples open), gently cycle the brake pedal up and down whilst keeping the reservoir topped up, to move any air bubbles displaced from the ABS unit down the hydraulic lines. Finish by closing each nipple with the pedal down.
3. Repeat step (1) to purge each calliper feed line in turn.

## JL.4 - BRAKE PAD REPLACEMENT (front and rear)

Pad thickness may be checked with the wheel removed without disturbing the calliper.

Standard pad thickness (excluding backplate); 12.0 mm  
Minimum pad thickness (excluding backplate); 2.5 mm



If the thickness of any pad is below the specified minimum, the axle set of pads should be renewed.

1. To remove the brake pads; Use a pin punch to tap one of the pad retaining pins towards the inboard side. Unhook and remove the anti-rattle spring plate, and tap out the second retaining pin. Use pliers on the backplate lugs to withdraw the pads from the calliper, noting each pad's position if they are to be refitted.  
Measure the lining thickness and renew the axle set of pads if any lining is below 2.5 mm.
2. Before replacing the pads, inspect the calliper for any signs of fluid leakage from a piston seal or joint, and replace the calliper if any such signs are evident. Clean the pad recess in the calliper taking suitable precautions to protect from dust inhalation. Inspect the brake disc surface condition and thickness (see below) and replace if necessary.
3. If refitting the existing brake pads, refit in their original position.

### Front Brake Shown

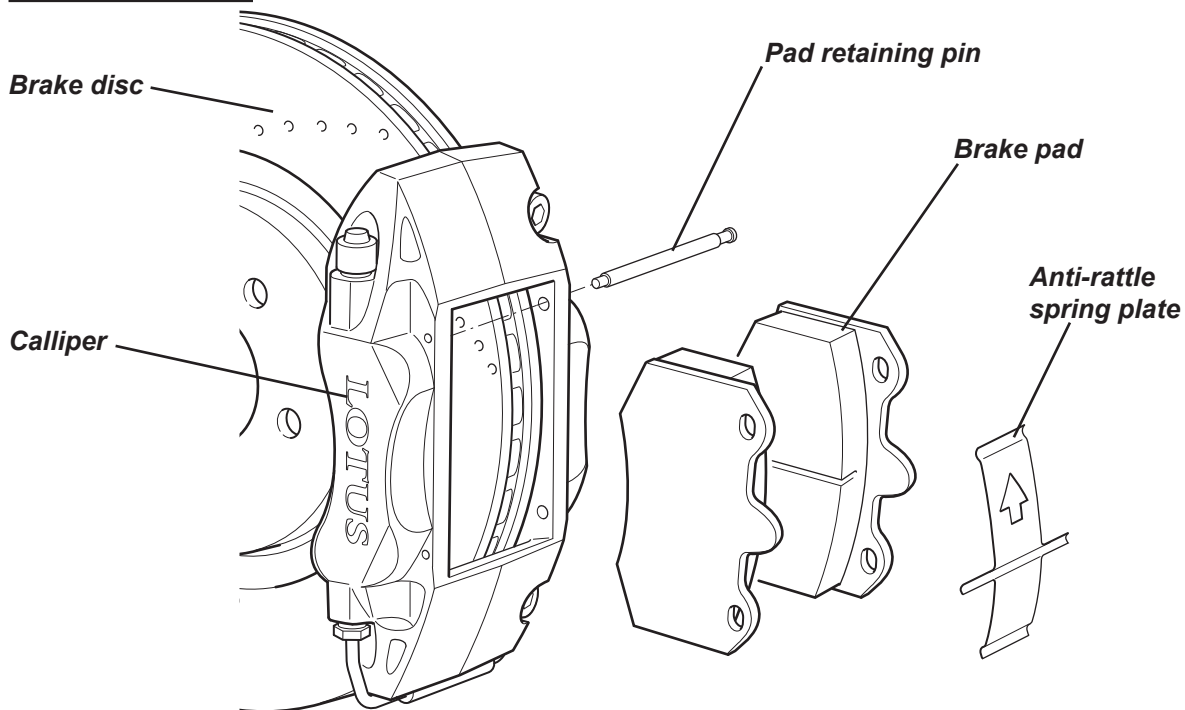

4. If fitting new pads, the pistons must be pushed back into the calliper using suitable calliper pliers, to provide the necessary space. This action will return fluid to the master cylinder such that some fluid may need to be removed by syringe in order to prevent overflowing. Do not lever between the disc and piston, or damage to both components may be caused. Note that new pads are supplied with an anti-squeal overlay applied to the backplate, and the edge of the pad material should be marked 'FER 4212 FF'.
5. Position the pads in the calliper, and insert the upper pad retaining pin from the inboard side. Tap fully into position using a pin punch, and verify the security of the pin. Renew the pin if in any doubt.
6. Fit the anti-rattle spring plate into position with the top end tucked under the upper pin and the arrow pointing upwards on a front calliper, or downwards on a rear calliper. Insert the second pin, pressing down the bottom of the spring plate so as to be captured by the lower pin. Verify pin security.
7. Before driving the car, press the brake pedal several times to bring the pads to their correct running position. Top up the master cylinder reservoir (see above) if necessary, to bring the level to the top of the 'MAX' mark.



8. Ensure the customer is made aware that maximum braking efficiency will be achieved if, for the first few hundred miles, needless heavy braking is avoided, and the brake pads are allowed to 'bed in' fully before being used to their full potential.

JL.5 - PARKING BRAKE MECHANISM

The parking brake ratchet lever is mounted between the seats in a fabricated steel structure which also houses the gearchange mechanism. The lever activates a primary cable which exits the cabin at the front of the fuel tank bay, and turns through 90° to connect to an equalising yoke at the front of the engine bay. The yoke forms the abutment for the primary outer cable, with the inner cable continuing through a slot in the yoke to link to the RH secondary cable. The opposite end of the yoke connects to the LH secondary cable, with both secondaries penetrating the rear subframe and routing through the lower wishbone to their respective rear wheel parking brake backplates. The interaction of the yoke with the three separate cables results in an automatically balanced force being applied to each of the secondary cables.

At the each brake backplate the secondary cable connects to a lever mechanism which provides a balanced expanding force to the lower ends of the parking brake shoes which operate within brake drums formed integrally with the rear brake discs. The upper ends of the shoes pivot against opposite ends of an adjustable length abutment, with access to the toothed adjuster screw available via a hole in the brake backplate.

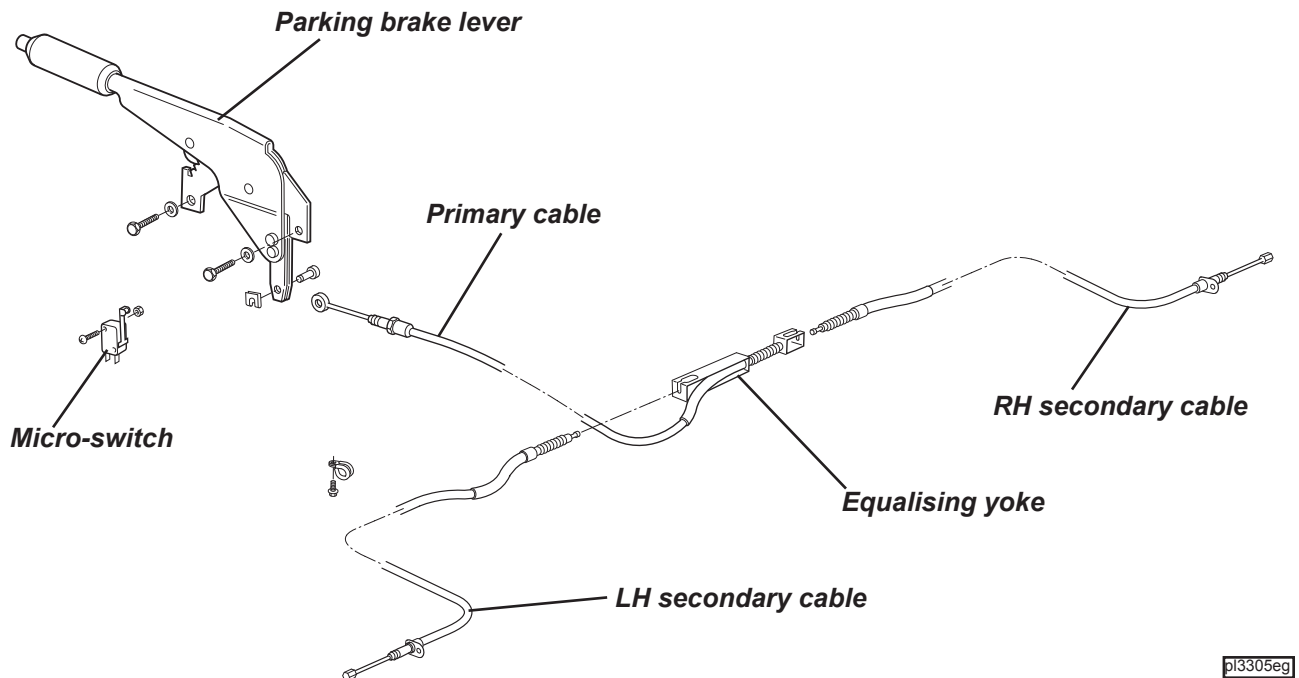

pl3305eg

The parking brake should be applied by pulling up the lever with high effort, and engaging the highest ratchet setting attainable. When parking the car on a slope, the additional precaution should be taken of leaving the transmission in first or reverse gear and steering the wheels towards the kerb.

**Adjustment**

At each service interval, the parking brake should be fully applied, and lever movement assessed by the number or ratchet 'clicks' attainable. The adjustment is satisfactory when 4 or 5 clicks are achieved.

To make an adjustment;

1. Ensure that the parking brake lever is fully off, and the adjuster in the LH secondary cable is fully slackened (shortened).
2. Remove both rear wheels. Using the access hole in the brake drum and hub flange, turn the adjuster downwards to expand the shoes until the brake drum cannot be turned by hand. Then back off the adjuster the minimum amount necessary to allow free rotation of the drum without rubbing, and then repeat for the opposite side.



3. The cable adjuster may then be tightened to remove slack until the 'click' specification is achieved. Check that there is no brake drag with the lever fully off.

### Parking Brake Shoes

Unless the parking brake shoes are mal-adjusted, the shoe material should suffer little wear. To remove the shoes, remove the road wheel, fully slacken the brake shoe adjuster, and remove the brake disc (see below). Mark the shoes with their fitting position before removing the steady pin and spring from each shoe by turning the pin 1/4 turn. Allow the shoes to fold outboard and release from the adjuster. Remove the upper retraction spring, and lever the shoes from the adjuster mechanism slots.

Refit in reverse order.

### Parking Brake Lever

The parking brake lever is mounted in a steel bracket which also houses the gearchange lever. The mounting bracket is bolted to an alloy support channel running down the centre of the cabin floor, to which it is secured by 12 setscrews. The brake lever ratchet pawl operates a micro switch to light the 'brakes' tell tale lamp in the instrument panel whenever the ignition is switched on and the parking brake is applied. The short front cable is connected to the lever assembly by a clevis pin with spring retaining clip. When carrying out any work in this area, take care not to damage or misroute the electrical main harness.

The two secondary cables are routed through the lower wishbones and into the brake backplates where the cable nipples connect to the actuation levers by a 1/4 turn.

### JL.6 - BRAKE DISCS

All four wheel brakes use a cast iron brake disc which is sandwiched between the wheel and its hub flange, being centralised by the hub spigot, and transmitting torque via the clamping force of the road wheel bolts. A countersunk screw is used to retain the discs for convenience when servicing. The 350 x 32 mm front discs and the 332 x 26 mm rear discs are all internally ventilated with directionally curved cooling vanes, and have cross-drilling to aid pad scouring available as an option. The rear discs also incorporate a 185 mm inner drum to accommodate the parking brake function.

The condition of the brake disc friction surface is a major factor in brake performance and feel, with a good surface quality and minimal run-out and thickness variation being required. After an extended lay up, some surface corrosion may develop on the discs which will cause a degradation in braking quality until the surfaces are cleaned up by normal brake action. Excessive run-out or thickness variation as a result of overheating or extended wear, may cause brake judder and/or extended pedal travel due to pad 'knock off'. Scoring and ridging of the braking surfaces will be exacerbated by operation in dusty or unmetalled road environments, and will degrade braking performance.

No skimming or re-surfacing of the brake discs is recommended. If the disc becomes badly scored, or is out of specification in any way, it should be renewed. NOTE: Ensure that there is no discernible free play in the wheel bearings before attempting to measure brake disc run-out. If disc run-out exceeds the service maximum, check the hub face run-out before replacing the disc.

### Brake disc thickness

New	- front	32 mm
	- rear	26 mm
Service minimum	- front	30 mm
	- rear	24 mm

### Runout

New maximum	0.06 mm
Service maximum	0.10 mm

### Hub

Disc mounting face run-out max.	0.05 mm
---------------------------------	---------

### Front Disc Replacement

1. Remove the road wheel.



2. Remove the two bolts securing the brake calliper to the hub carrier, and withdraw the calliper from the disc. Secure clear without straining the flexible hose.
3. Remove the single countersunk screw, and withdraw the disc from the hub.
4. Before re-fitting a disc, ensure that the mating face between disc and hub is scrupulously clean. Mount the correctly handed disc (with the curved vanes trailing in normal direction of rotation) onto the hub spigot, align the fixing screw hole, and secure the disc with the screw, tightening to 10 Nm.
5. Apply Permabond A130 (Blue - A912E7033) to the threads of the calliper fixing bolts. Fit the calliper with pads over the disc and secure to the hub carrier with the two bolts. Tighten to 86 Nm.
6. Refit the road wheel and when all brakes are assembled, pump the brake pedal to restore brake pad position before driving the car.

### Rear Disc Replacement

Replacement of the rear discs is similar to that for the front discs, except that the adjuster for the parking brake shoes should first be slackened to allow easy withdrawal of the disc/drum. Re-adjust after re-assembly.

### JL.7 - BRAKE CALLIPERS

The brake callipers are supplied by A.P. Racing, and feature lightweight alloy bodies housing four pistons in opposed pairs. The castings for the front and rear callipers are common, but are machined differently to accommodate the differing piston diameters. In the front callipers, the leading pistons are 38.1 mm diameter, and the trailing pistons 41.3 mm. The rear callipers house 38.2 mm leading pistons and 36.0 mm trailing. Each calliper is marked on its inner, inboard face, alongside the pad aperture, with its designated fitting position; 'RF' representing Right hand Front, with others marked as LF, RR, and LR.

Each calliper is secured to its hub carrier by two bolts disposed in a plane perpendicular to the disc axis, with the front callipers mounted behind the axle line, and the rear callipers ahead of the axle.

The brake callipers are to be dismantled or overhauled only A.P. Racing at Wheeler Road, Seven Stars Industrial Estate, Coventry, CV3 4LB.

Front calliper fixing bolt torque; 86 Nm using Permabond A130.

Banjo bolt, flexi hose to calliper; 20 Nm.

Flexi hose to subframe bracket; 16 Nm.

### JL.8 - BRAKE MASTER CYLINDER

The Continental Teves tandem master cylinder incorporates a rear section to supply both front brakes, and a front section to supply the rear brakes. A translucent fluid reservoir is mounted on a bracket above the master cylinder, and is divided into front and rear chambers separated by a weir. The two chambers are connected to the front and rear master cylinder sections by flexible hose, with a third hose connecting the rear brake reservoir chamber to the clutch master cylinder to supply that system's needs. A fluid level sensor in the filler cap will light a fascia tell tale lamp if the level becomes dangerously low.

The master cylinder is secured to the front face of the brake servo which itself is bolted to the front of the pedal box. Access is available only after removal of the front clamshell. The master cylinder manufacturer does not recommend any dismantling of the unit, and supplies no replacement parts or internal components. If the cylinder is faulty it should be renewed as a complete assembly.

To remove the unit, proceed as follows:

1. Remove the front clamshell (see Sub-section BV.4) and radiator air outlet duct.
2. Syphon fluid from the reservoir to reduce spillage. Release the two hoses connecting the master cylinder to the fluid reservoir, and plug the hoses. Disconnect the electrical cables from the reservoir cap.
3. Release the two brake pipes from the master cylinder, and plug the pipes and ports.



4. Release the two nuts securing the master cylinder to the brake servo and remove the cylinder.
5. Refit the master cylinder in reverse order to removal, using new locknuts and tightening to the following torques:
  - Master cylinder fixing nuts; 25 Nm
  - Brake pipes to cylinder; 16 Nm
6. Fill the reservoir with DOT 4 non-mineral type brake fluid, and bleed the complete brake system of air using the procedure in Sub-section JL.3.

### JL.9 - VACUUM SERVO UNIT

The vacuum brake servo is secured to the front face of the pedal box via a machined alloy spacer, and is operationally interposed between the brake pedal and master cylinder. Engine generated vacuum is used to provide pneumatic assistance to the effort applied at the pedal. The unit is supplied by Continental Teves and is a dual diaphragm unit combining a 178mm (7 in) and 203mm (8 in) diameter vacuum chamber into a single compact unit to provide a 5:1 assistance ratio. With the exception of the air filter and vacuum elbow/non return valve, the unit is a non-servicable sealed unit which if found to be faulty, must be replaced as an assembly. The air filter (surrounds the input push rod) should be replaced whenever the brake system is overhauled, and cleaned or replaced more frequently if the vehicle is operated in dusty conditions. A non-return valve is incorporated into the vacuum hose elbow connector in the front case of the servo unit. The elbow connector valve is a push fit into a grommet in the servo shell, and is supplied complete with the grommet.

The servo is of the 'suspended in vacuum' type, wherein two flexible diaphragms divide each of two sections within the steel shell into two chambers. One pair of chambers, towards the front side of each diaphragm, is connected via a non-return valve, to the vacuum produced in the engine's inlet plenum chamber. The second pair of chambers, towards the rear side of each diaphragm, connect either to the front chambers, or to atmosphere, under the control of a double acting face valve.

#### **Brakes Off**

When the brake pedal is released, the diaphragms and driving piston are pushed fully rearwards by the main spring, and the input rod (connected to the brake pedal) is also pushed rearwards by its own spring, causing the face valve to close the atmospheric connection. Engine vacuum admitted to front of the diaphragms is also communicated to rear of the diaphragms via the face valve. The unit is in stable equilibrium.

#### **Initial Movement**

Initial movement of the brake pedal causes the input rod, input piston and face valve to move forwards, closing off the front/rear communication.

#### **Pressure Balance**

Further pressure on the brake pedal pushes the input piston further forwards and opens the face valve to bleed atmospheric pressure into the rear chambers. The resultant pressure imbalance across the diaphragms acts to apply a force to the driving piston to assist pedal effort. When the combined input force from foot pressure and servo pneumatic pressure balances the reaction force of the main spring and master cylinder, movement of the driving piston ceases, and both face valve ports close. The system is once again in equilibrium.





**Tandem Servo Section (brakes off)**

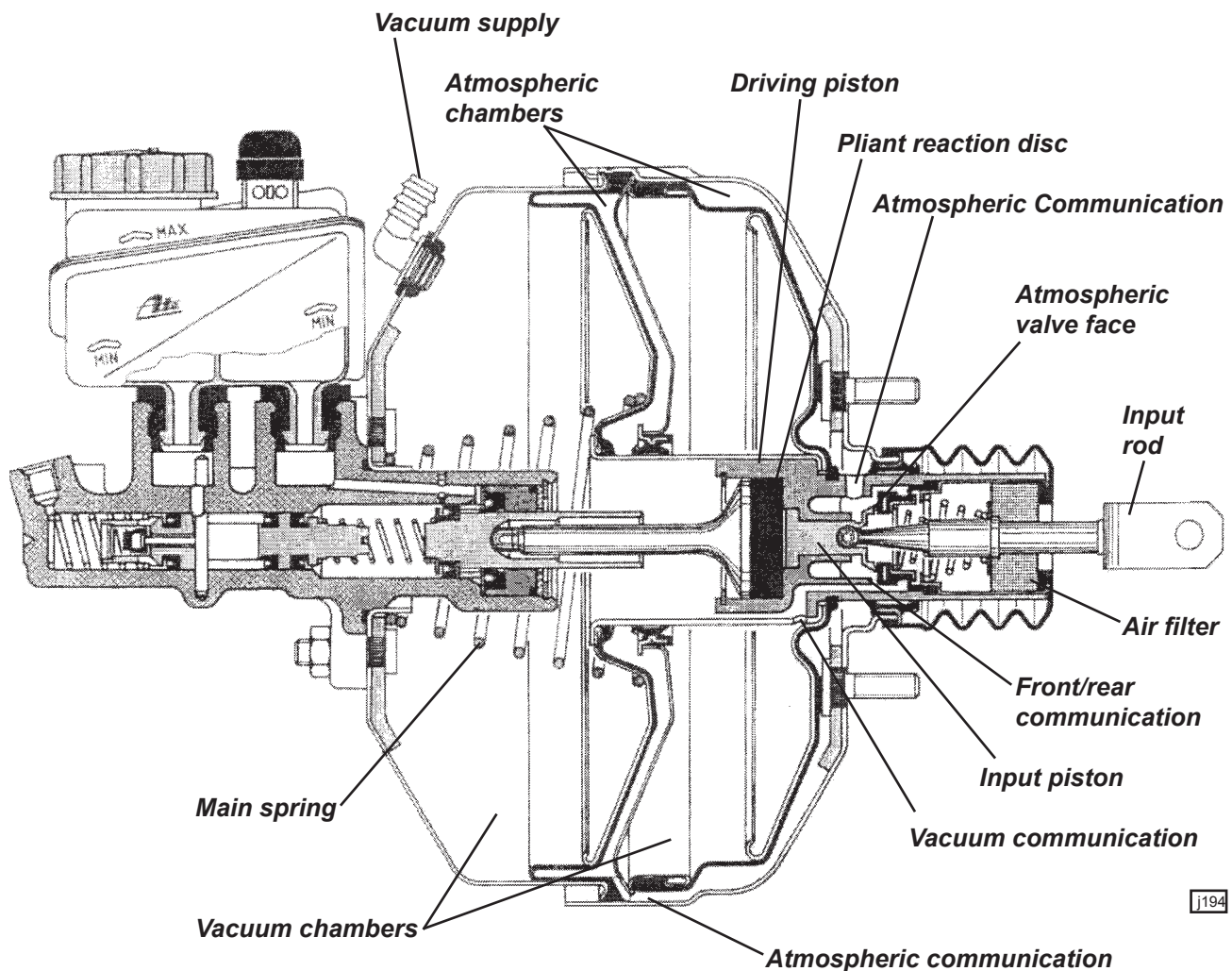

From this position of equilibrium, further pressure on the pedal will tend to open the atmospheric valve face and allow pressure in the rearward chambers to increase, and move the driving piston forwards before again stabilising. Any reduction in pedal pressure will tend to open the front/rear valve face and allow the higher pressure in the rearward chambers to bleed off into the frontal chambers, whose depression is kept low by connection to the intake plenum. The pressure imbalance allows the driving piston to move rearwards under the action of the main spring and master cylinder, until equilibrium is regained.

**Maximum Assistance**

At around 900N of input rod pressure, the atmospheric port will be held open, so that the rearward chambers will be subject to full atmospheric pressure. This constitutes maximum servo assistance which will, with 0.8 bar of vacuum available from the engine, increase the force applied to the master cylinder pushrod by a factor of five.

The pliant reaction disc fitted between the input and output rods ensures a graduated application of servo assistance and provides pedal feedback and 'feel' to the driver.

**Operational Check**

As a quick check of servo operation proceed as follows: With the engine stopped, press the brake pedal several times to exhaust the servo unit of vacuum. Keeping the pedal pressed (which should be 'hard' and 'high'), start the engine; The pedal should drop slightly as the servo vacuum builds up, and extra force is produced. If the pedal does not drop, it is most likely that there is a fault in the vacuum supply line. Check the vacuum hose, all connections and the non-return valve. If the vacuum supply is not defective, the servo unit should be replaced.



*Setting brake pedal:* It is essential that the servo piston (and master cylinder piston) is allowed to return fully when the brakes are released, and is not pre-loaded by mal-adjustment of the input pushrod. See (4) below.

*Stop light switch:* The stop switch is mounted in a right angle bracket fixed to the underside of the scuttle, and abuts directly against the pedal. The switch is retained in the bracket by a quarter turn mechanism, with no adjustment provided or required.

### To Replace Brake Servo Unit

1. Remove the brake master cylinder (see sub-section JL.7).
2. From within the footwell, disconnect the servo pushrod from the brake pedal.
3. Disconnect the brake servo vacuum hose, and release the four nuts securing the servo to the pedal box extension plinth. Withdraw the servo assembly.
4. Before replacing a servo unit, first check the adjustment of the clevis on the input pushrod (i.e. the effective length of the pushrod). With a new rubber gasket fitted over the four servo mounting studs, the perpendicular distance from the surface of the gasket to the axis of the clevis pin hole should be 133mm.
5. Replace the servo in reverse order to the above, tightening the servo mounting nuts to 25 Nm, and the master cylinder new fixing nuts to 25 Nm. Check pushrod adjustment (see sub-section JL.9) and bleed the hydraulic system (see sub-section JL.3)

### JL.10 - PEDAL BOX

The pedal box is fabricated from alloy sheet, and rivetted, bolted and bonded to an aperture in the chassis scuttle. A hollow steel pivot shaft serving the brake and clutch pedals is bolted to a steel mounting plate, itself bolted to the inside of the pedal box. The brake and clutch pedals are fabricated from steel plate, and feature synthetic bushes for maintenance free articulation on the steel pivot shaft, and serrated alloy footpads. The brake pedal uses a coil pull off spring, and the clutch pedal is equipped with an overcentring coil spring linkage, in order to reduce the pedal effort required to maintain full clutch disengagement. A clutch pedal potentiometer is also fitted in order to provide data for Cruise Control operation, and for the start inhibit function on Canadian market cars.

The 'drive by wire' throttle actuation uses a steel rod fabricated pedal to operate an electronic module and provide a signal to the engine ECU, which then actuates the throttle valve stepper motor within programming constraints. The throttle pedal module is secured to a mounting bracket by three bolts, with a further three bolts fixing the bracket to the pedal box.

#### *Pedal Removal*

To remove the throttle pedal assembly complete with mounting bracket, disconnect the harness plug from the module, and remove the three bolts securing the bracket to the pedal box.

To remove a brake or clutch pedal from the pivot shaft, the pedal shaft mounting plate must be removed from the pedal box complete with the brake and clutch pedals:

1. Unplug and remove the throttle pedal assembly complete with mounting bracket by releasing the three screws securing the bracket to the pedal box.
2. Disconnect the brake and clutch pedals from their pushrods, and unhook the brake pedal return spring.
3. Unplug and remove the clutch pedal position switch with mounting bracket, by releasing the two bolts securing the bracket to the pedal box.
4. Release the clutch pedal assist spring anchor bracket from the pedal box side (3 bolts).
5. Remove the two bolts securing the clutch master cylinder assembly to the pedal box and support the cylinder aside.



6. Remove the 4 remaining fixings securing the pedal shaft bracket to the pedal box, and manoeuvre the pedal assembly from the car.
7. Release the three Torx head screws securing the pedal shaft and withdraw the shaft and pedals
8. Refit the pedals in reverse order to removal, noting that the pivot bushes of the brake and clutch pedals should be lubricated with Syntheso GLK1 or equivalent.

<b>Torque Settings</b>	<b>Nm</b>
Brake servo to alloy spacer	25
Pedal shaft bracket to pedal box	16
Throttle pedal mounting bracket to pedal box - M6	16
- M8	25

### JL.11 - ABS THEORY OF OPERATION

The Bosch antilock brake system is an 'add on' type used to supplement the dual circuit, tandem master cylinder, vacuum servo assisted brakes fitted to the Evora. A single electro-hydraulic unit comprising a hydraulic modulator, hydraulic pump, microprocessor and solenoid valve bank, is flexibly mounted on the forward side of the driver's toebox, and plumbed into the front and rear brake circuit lines from the tandem master cylinder.

The microprocessor receives signals from magnetic wheel speed sensors integrated into each of the four road wheel hubs, and interprets the individual wheel acceleration, deceleration, and comparative wheel speeds. From this data, the processor is able to determine if any wheel is tending to lock up, and if imminent lock up is sensed, the unit commands the relevant solenoid valves firstly to reduce pressure in that particular brake circuit in order to restore wheel speed, and then to modulate pressure to that providing the maximum braking force consistent with continued wheel rotation. The system is able to monitor and independently control each of the four wheel brakes, and is referred to a 4-channel system.

In order to achieve the required pressure modulation, three basic modes are used:

- Pressure hold;
- Pressure reduction;
- Pressure increase;

In order to maintain the safety provision of two entirely independent hydraulic circuits, one for the front brakes, and one for the rear, the hydraulic elements of the control unit are doubled up, with no part of the system shared between the two circuits. For the pressure hold function, four isolation solenoid valves are used, one in the hydraulic circuit for each wheel brake. The pressure reduction function is achieved by a separate dump solenoid valve in each of the four wheel brake circuits, and the pressure increase provided for by a single electric motor operating two hydraulic pumps, one serving the front, and on the rear brake circuit. Separate low pressure accumulators are used for the front and rear circuits.

#### **Electro-Hydraulic Control Unit**

The electro-hydraulic control unit comprises an alloy valve block containing the four isolation valves, four dump valves, two hydraulic pumps and two accumulators, with the single pump motor screwed to the housing, and with a solenoid block and ECM unit attached. The complete assembly is flexibly mounted via a bottom spigot and two threaded studs, each of which engage with a rubber grommet in a mounting bracket secured by 4 bolts to the front side of the driver's toebox. A protective alloy shield is secured by two nuts.

The isolation and dump valves share a similar construction, but the spring loaded isolation valves are normally open, and the dump valves normally closed.



**Anti-Lock Braking**

Maximum braking force is provided from a tyre when there is around 15% slippage, dependent on road surface conditions and tyre characteristics. The function of the ABS is to limit tyre slippage when braking to around this figure in order to provide optimum grip, and also, by preventing wheel lock, to ensure that steering control of the vehicle is retained.

A high brake pedal pressure (or low road surface friction) may initiate the locking of one or more wheels. In the diagram below, a typical control strategy is shown:

1. Normal braking occurs until, as the applied pressure increases, the wheel speed signals received by the ECM indicate that the left hand front wheel (for example) is tending to lock. i.e. its deceleration is too rapid, with too great a speed differential with the other wheels.
2. The connection between the master cylinder and the LH front brake circuit is interrupted (by the isolation valve), and the rate of slip increase is reduced.
3. If the wheel speed continues to depart significantly from vehicle speed, the dump valve is energised to reduce pressure in the LH front circuit until wheel speed begins to increase. The dump valve is then closed, as is the isolation valve.
4. As wheel speed approaches that providing optimum grip, the isolation valve is pulsed open to allow a stepped pressure increase.
5. As wheel speed begins to drop off and depart from vehicle speed again, a new cycle starts, repeating steps (1) to (4).
6. When wheel speed increases sufficiently to meet vehicle speed, ABS intervention ceases, although monitoring is continued throughout each braking event.

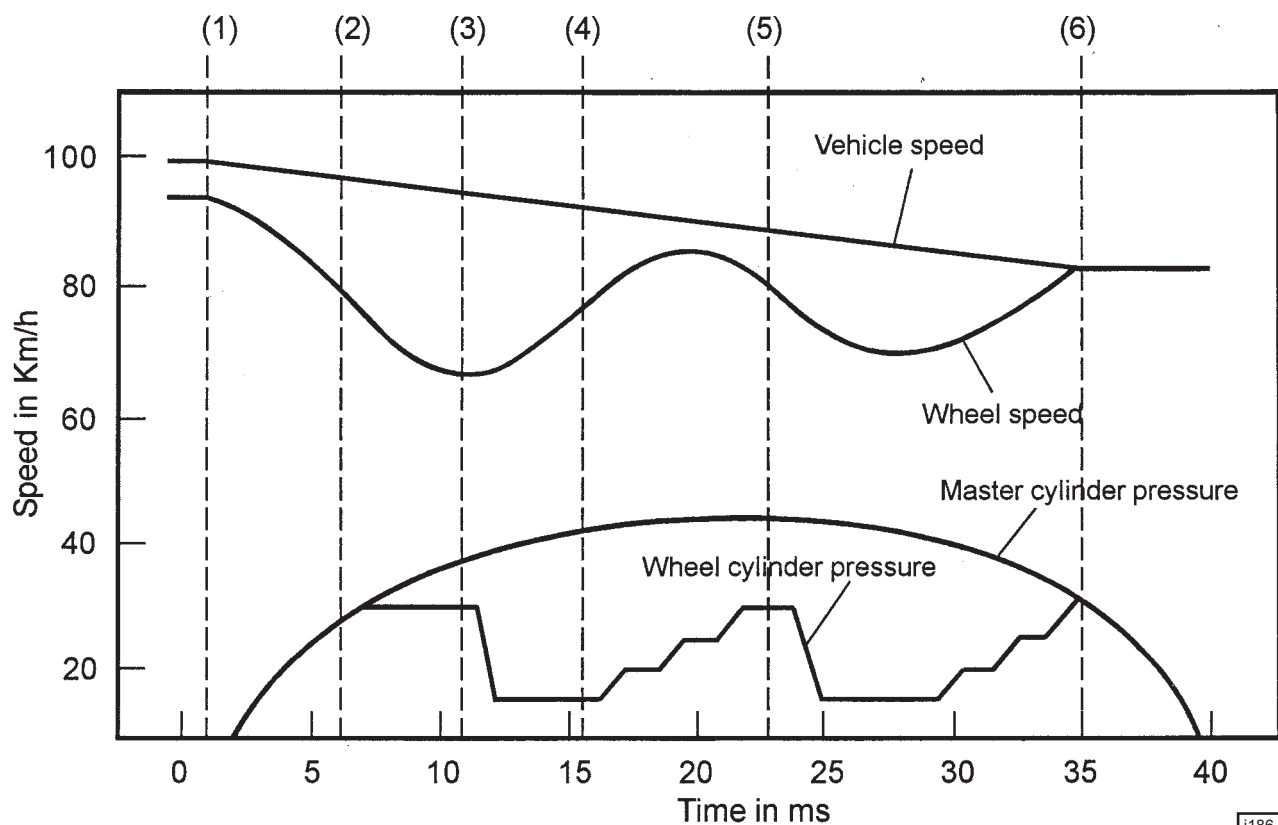

j186



**Sequence of Operation**

In the following diagrams, one half of the hydraulic modulator is shown schematically, representing the front brake control circuit, with the sequence of operation described for the left hand front wheel brake. This sequence would be similar for any of the other three wheel brakes. A typical emergency braking event is described where, in this example, the left hand front wheel tends to lock. Note that the complete system is duplicated for the rear brake circuit, which remains completely independent of the front circuit.

**Normal Braking**

During normal braking, when the wheel speed sensors indicate no imminent wheel locking, the ABS is inactive. The solenoids are unenergised, so that the isolation valves are sprung open, and the dump valves are sprung closed.

Hydraulic fluid from the master cylinder enters the modulator via the inlet port, by-passes the attenuator orifice, passes through the open isolation valve and out to the LH front wheel brake.

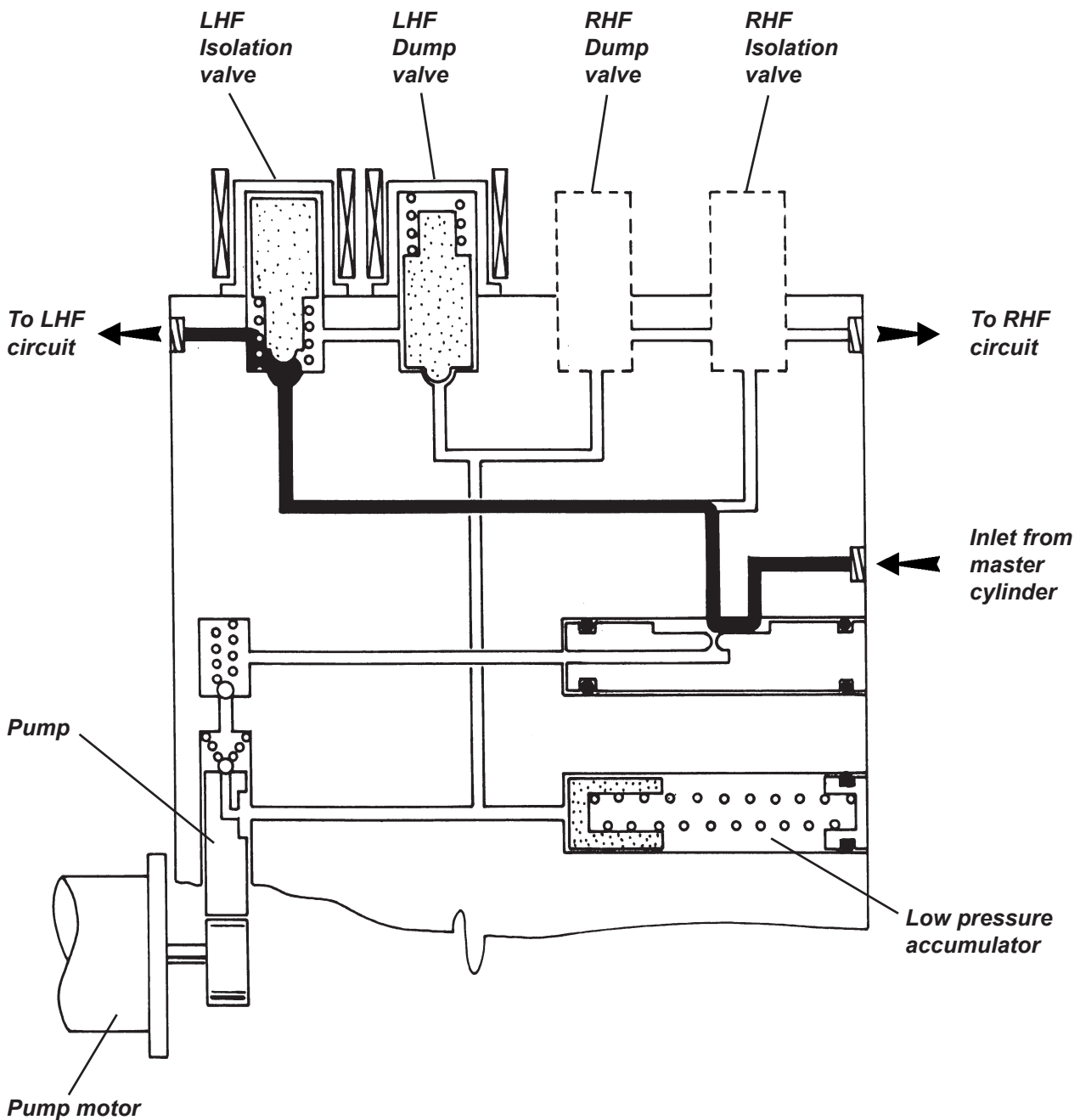

j149a



**Pressure Isolation (Pressure Maintain)**

If signals received from the wheel speed sensors indicate imminent lock up of the LH front wheel, the first step in the anti-lock sequence is to isolate that wheel brake circuit from the master cylinder. The ECM energises the isolator valve solenoid, which closes the valve against spring pressure and maintains existing pressure in the left hand front brake circuit regardless of any increase in pedal pressure.

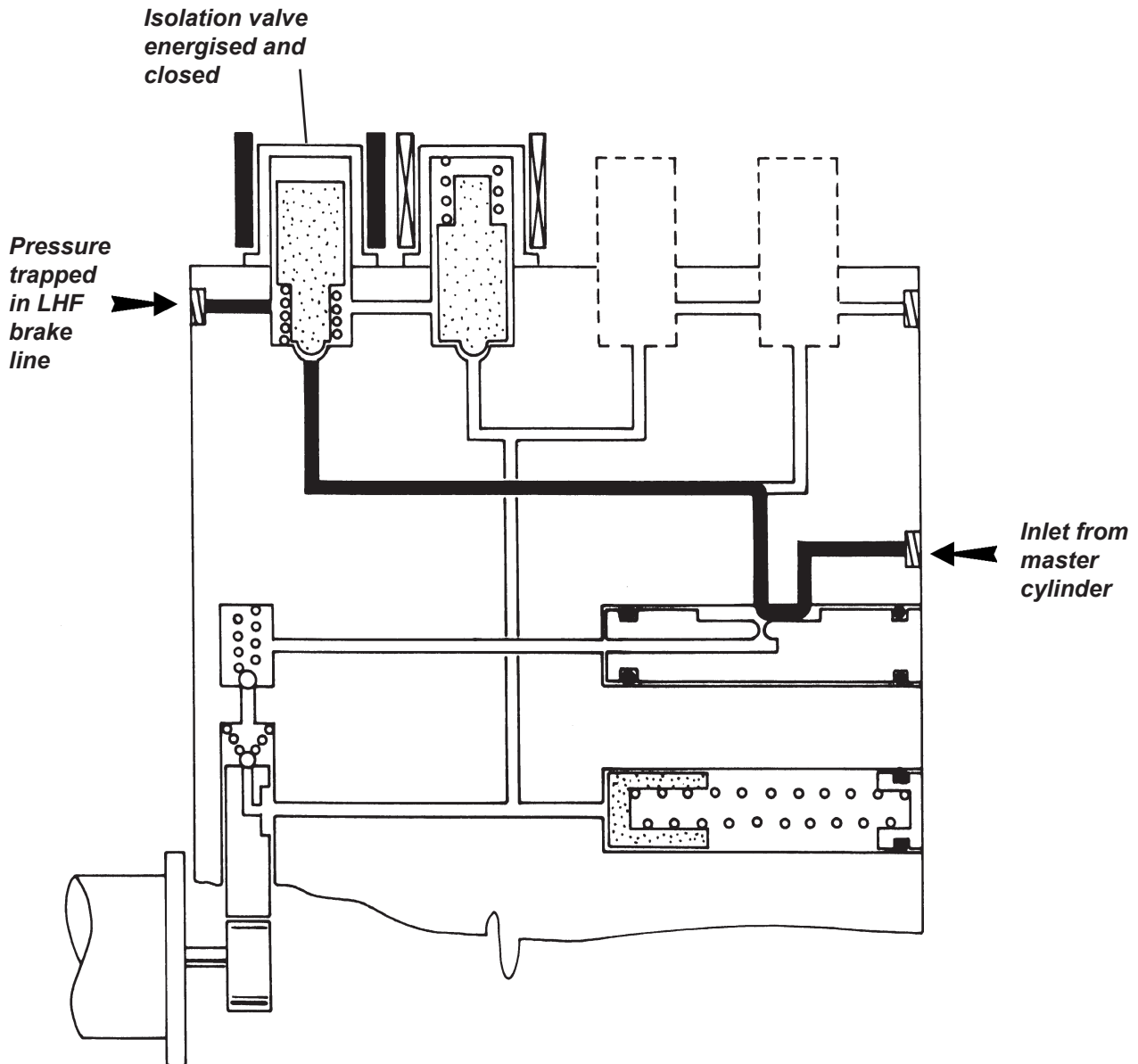

j149b



**Pressure Reduction**

Once the LH front wheel brake circuit has been isolated from the master cylinder, the pressure must be reduced in order to allow wheel speed to be restored. This pressure reduction is achieved by the ECM energising the dump valve solenoid, which then opens against spring pressure and bleeds off some of the fluid into the low pressure accumulator shared with the RH front circuit. Very short activation pulses are used to maintain close control of the pressure reduction, and to limit the reduction to that required to restore wheel speed. Fluid displaced from the wheel brake circuit is stored in the front brake accumulator against spring pressure, and is also used to prime the hydraulic pump.

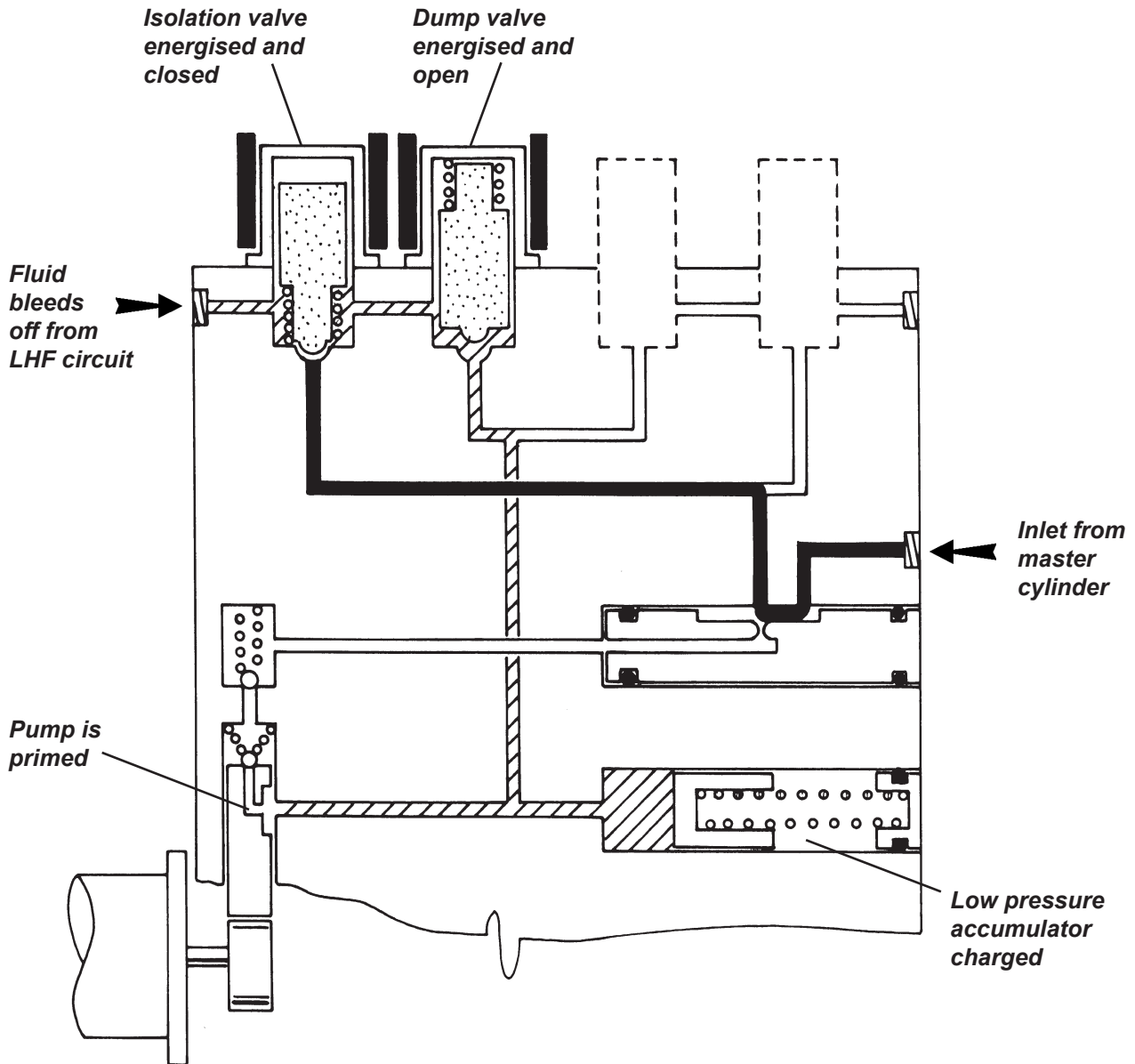

j149c



**Pressure Increase (Re-apply)**

As soon as imminent wheel lock is detected by the ECM, and the ABS control system is activated, the pump motor is energised. When the dump valve is opened, and fluid is allowed to bleed off from the wheel brake circuit into the low pressure accumulator, this fluid is scavenged by the pump and returned back into the input circuit through an attenuator orifice. This action is the origin of the 'pedal pushing back' sensation felt by the driver, with the pressure pulsations from the pump damped and quietened by the restriction of the orifice. When wheel speed has been restored and the brake pressure is required to increase, the isolation valve is momentarily opened, to allow master cylinder/pump pressure to raise the pressure in the wheel brake circuit in increments. If imminent locking is again sensed, the isolation valve closes, the dump valve opens and the cycle repeats, with the whole process occurring several times a second.

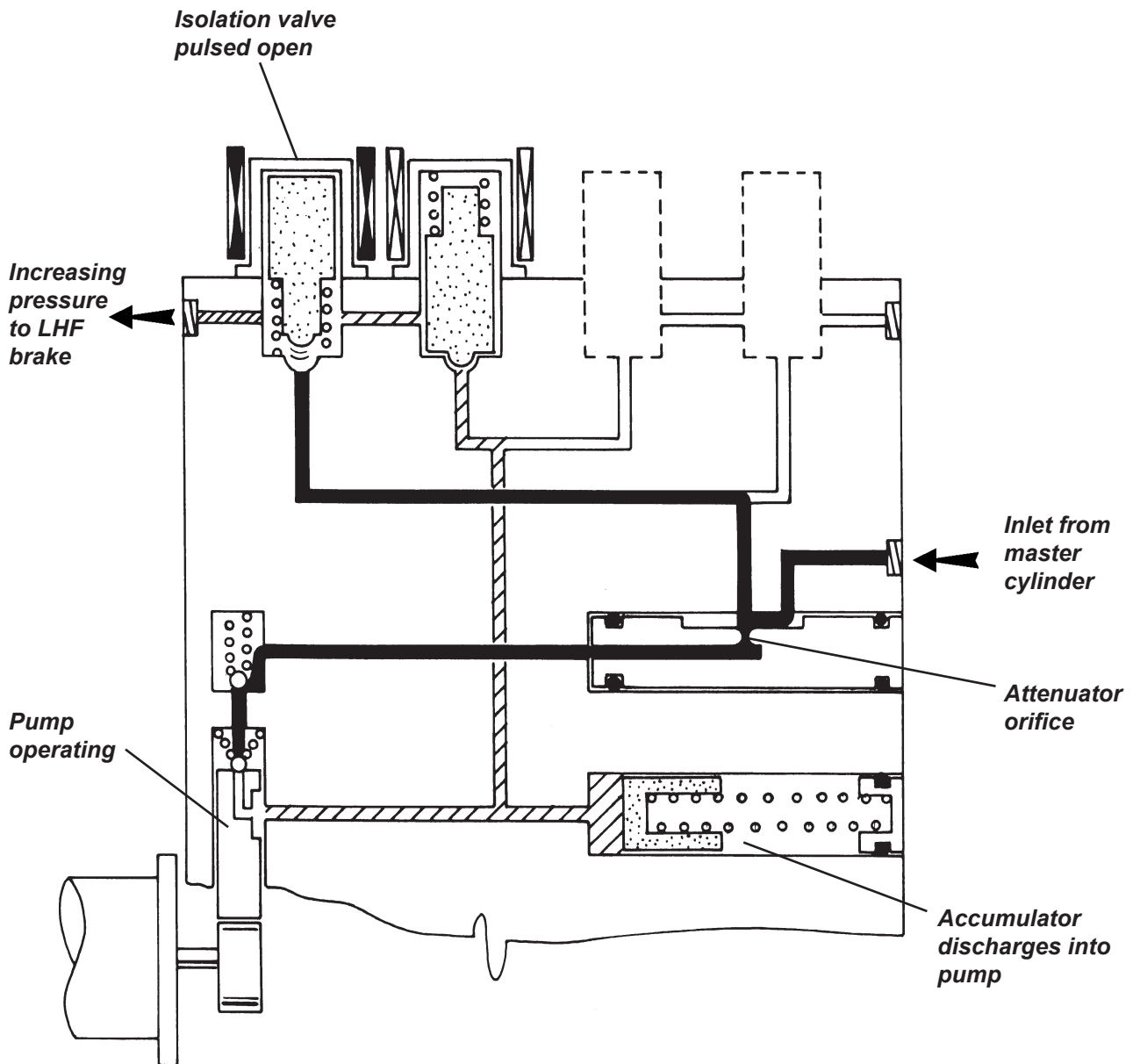

j149d





**Brake Release**

When no further wheel locking is sensed by the ECM, the ABS becomes inactive with the isolation valve open (solenoid de-energised) to allow direct communication between the master cylinder and wheel brake circuit, and the dump valve closed (solenoid de-energised) to seal off the pressure relief circuit. The pump will remain running for a short time to help drain any fluid from the accumulator, whose piston is returned to its start position under the action of the spring, and return the fluid to the master cylinder reservoir.

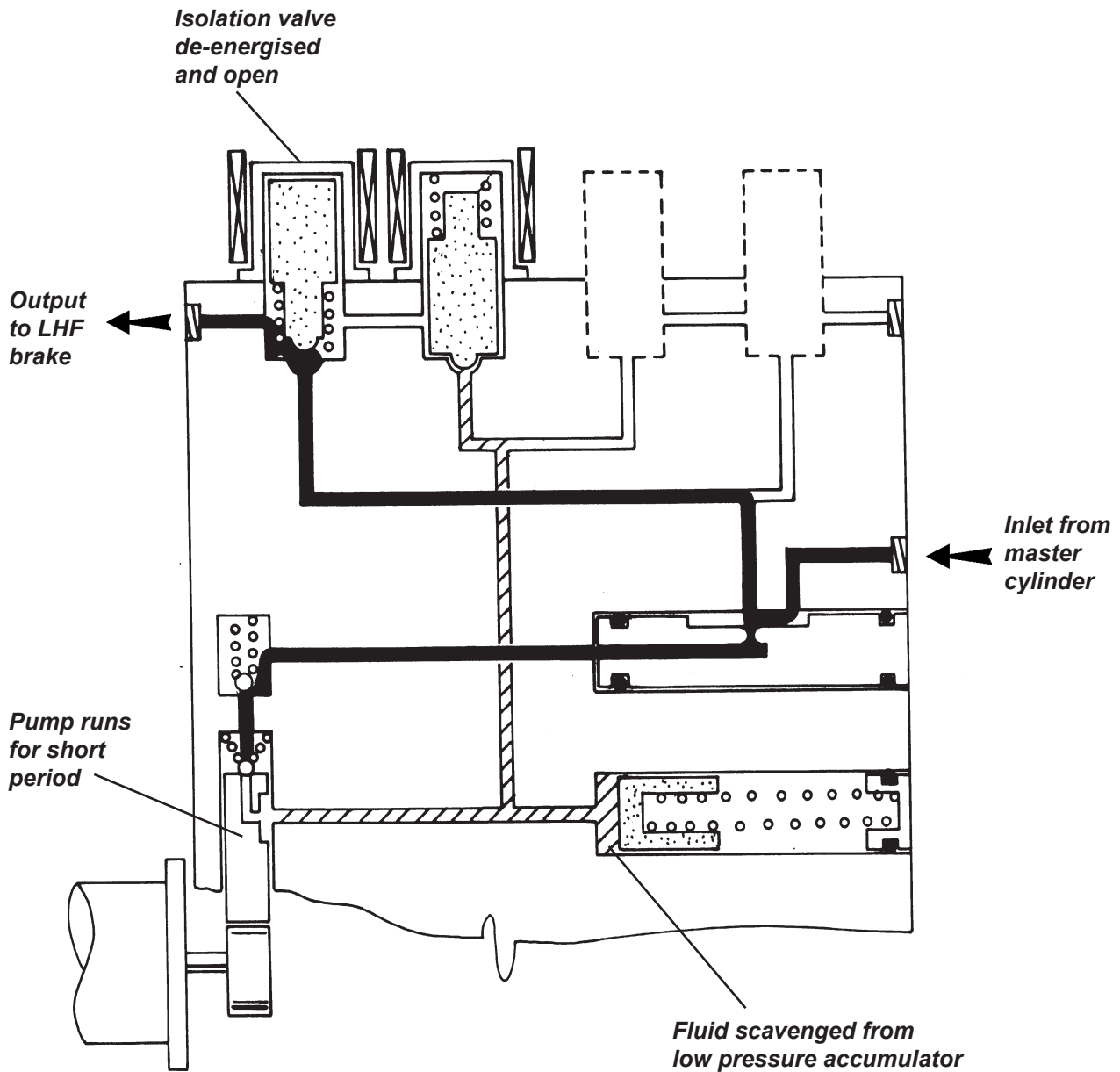



## JL.12 - ELECTRO-HYDRAULIC UNIT

The electro-hydraulic unit is located on the front side of the driver's toebox, and is accessible from below after removal of the front undertray. The protective cover may be removed after slackening the two retaining nuts. The unit is secured to the mounting bracket via two studs and a bottom spigot, all supported in flexible grommets. The mounting bracket is fixed to the chassis by four bolts. A single 38 pin connector plug with a cam lever is provided to connect the vehicle harness to the control module.

**CAUTION: Do not disconnect or connect the main connector plug with the ignition switched on. Switch off the ignition and disconnect the harness before carrying out any electrical welding operations on the car.**

Hydraulic pipe connections to the unit comprise two input pipes from the master cylinder (one for the front circuit, one for the rear) and four output pipes, one for each of the wheel brakes. Note that all hydraulic connections are identified by engraved markings on the unit:

*Input:*

- MC1 From master cylinder rear port (front brake circuit)
- MC2 From master cylinder front port (rear brake circuit)

*Output:*

- FL Front left
- FR Front right
- RR Rear right
- RL Rear left

### **To Remove Electro-Hydraulic Unit**

When removing the unit, beware of dripping brake fluid and take appropriate precautions to prevent damage to paintwork.

1. Raise the vehicle and remove the front undertray. Remove the module protective cover.
2. Switch off the ignition before pressing the release tab and folding back the cam lever to disconnect the harness plug.
3. Label each of the hydraulic pipes before disconnecting from the unit and immediately capping the pipes and plugging the ports to reduce the spillage of brake fluid, and to prevent the ingress of dirt.
4. Release the four bolts securing the mounting bracket to the chassis and withdraw the bracket with ABS unit.
5. To remove the unit from the bracket, release the two retaining nuts from the studs and slide the unit from its three grommets.
6. To refit, reverse the removal procedure, taking care to connect the brake pipes correctly:
  - Mounting bracket to chassis; 24 Nm
  - Modulator inlet pipes; 18 Nm
  - Modulator outlet pipes; 16 Nm
7. Bleed the unit of air (see Sub-section JL.3).
8. Verify correct connection by using the 'Lotus Techcentre' tool in actuator tests with the car on a wheel free lift. Check that operation of each solenoid valve affects the appropriate wheel.

**Note that the ABS controller is calibrated specifically for the Evora. Do not use parts from other sources.**



### JL.13 - WHEEL SPEED SENSORS

A 48 pole vehicle speed sensor ring is integrated into the hub inboard grease seal, the signal from which is read by a sensor inserted into the rear of the hub carrier and retained by a single button head socket screw.

Wheel speed data is supplied to the ABS control module, which uses the information to modulate brake system pressures, and also outputs a road speed signal to the engine ECM, and to the instrument pack for speedometer operation. Output from each wheelspeed sensor can be checked using the Lotus TechCentre.

### JL.14 - DATA LINK CONNECTOR (DLC)

The Data Link Connector (DLC) is a 16 terminal electrical connector plug, complying with SAE J 1962, which provides a means of communication with the ABS and engine management electronic control units. The connector is used in service to connect electronic diagnostic equipment such as the 'Lotus TechCentre' tool which allows system interrogation including the reading of trouble codes.

The DLC is located on the back of the scuttle crossbeam above the outboard side of the driver's footwell.

### JL.15 - SPECIAL TOOLS

#### **Lotus TechCentre**

##### *Can Bus Diagnostics*

Controller Area Network (CAN) is an electronic standard to allow high speed communication between modules and controllers, via a serial data bus. The bus is a circuit linking the modules to the controller, consisting of a pair of cables, twisted together to reduce electromagnetic interference, and carrying a square wave voltage signal corresponding to '0's and '1's, coded in such a way as to identify and prioritise the individual messages. On the Evora, CAN based systems include; engine management, anti-lock braking, safety restraint, instrument pack and tyre pressure monitoring (where fitted).

A 'stand alone' lap top PC loaded with 'Lotus TechCentre' software allows the CAN based serial data to be read. Updates and support are accessed via an internet connection.

A Vehicle Communication Device (VCD), part number T000T1476F, is used to connect the vehicle to the lap-top Lotus TechCentre. Engine programming, live data display, diagnostics of engine, ABS and airbag systems, and service tell tale lamp resetting (where applicable) are all carried out via the Lotus TechCentre.

The minimum specification of the laptop computer for installation of the Lotus Techcentre is as follows:

Processor 1.70 Ghz;  
1 GB RAM;  
40 GB HDD;  
CDRW DVD ROM;  
WIN XP PRO;  
USB interface;  
Ethernet or Wireless LAN

Note that it is recommended that this laptop be dedicated solely to the Lotus TechCentre, with no other software installed. A licensing/support fee will also apply, to be charged monthly or annually.



## JL.16 - 'LOTUS TECHCENTRE' CHECKING PROCEDURES

### 1. Trouble Codes

When the ABS controller detects a fault in the system, the following events occur;

- i) The ABS tell tale is lit;
- ii) The anti-lock system is switched out;
- iii) A trouble code is stored in the non volatile random access memory i.e. memory which is retained when the power supply is interrupted, or the battery disconnected.

Trouble codes may be either Condition Latched, or Ignition Latched:

*Condition Latched;* With this type of fault, which is generally low or high voltage, the ABS tell tale will light, and the anti-lock system switch out, until such time as conditions return to normal, at which point the light will be extinguished, and the anti-lock be reinstated. The trouble code will be stored only whilst the fault is present.

*Ignition Latched;* This type of fault, of which are most categories, will cause the tell tale to be lit and the anti-lock to be inhibited until such time as the fault is no longer detected at the moment of a subsequent switching on of the ignition. At this point, the lamp will be extinguished, and the ABS restored, but the trouble code will be retained in the memory for the next 20 drive cycles i.e. ignition switched on and a minimum road speed of 5 mph attained.

Access to diagnostic codes is available by using the Lotus TechCentre laptop PC connected to the Diagnostic Link Connector (DLC - see JL.14). This tool allows the display of any stored trouble codes and sensor readings as well as allowing manual operation of actuators.

The facilities available include:

- Viewing fault codes/wheel speeds/valve activities.
- Clearing fault codes.
- Generating valve/motor activities.
- Reading EEPROM contents.
- Reading ECM identification.
- Updating ECM calibration.

#### *Important Notes*

- Whenever the Lotus TechCentre tool is connected, the ABS tell tale is lit and the anti-lock function is inoperative.
- Never connect or disconnect the DLC to/from diagnostic equipment with the ignition switched on.
- Unless using a trickle 'battery conditioner' type charger, disconnect the vehicle battery before charging or boost charging.
- Never disconnect the battery from the vehicle electrical system with the engine running.
- Never use a quick-charger for starting.
- Take care when touching energised parts of the ignition system.
- ECMs must be removed prior to welding operations, or subjecting to oven temperatures above 80°C.
- When voltage testing, use only a high-resistance type meter.
- During test steps which involve the connection of contacts from harness plugs or control units with ground or battery voltage (+12V), exercise great care as incorrect contact can cause permanent damage to the ECM internal circuits.
- When measuring resistance from ground bearing wires to vehicle ground, the nominal value of 'less than 2 ohms' sometimes cannot be achieved. In this case, disconnect the negative (ground) post of the battery and measure the resistance to the vehicle earth lead.
- Always erase trouble codes from any control unit after a test is done.



**2. Abbreviations & Definitions**

BATTERY VOLTAGE	System voltage
BRAKE LIGHT SW.	Brake light switch
FL WHEEL SPEED	Front left wheel speed
FR WHEEL SPEED	Front right wheel speed
RL WHEEL SPEED	Rear right wheel speed
RR WHEEL SPEED	Rear right wheel speed
FRONT WHL SPEEDS	Front wheel speed
REAR WHL SPEEDS	Rear wheel speed
VALVE RELAY CMD	Valve relay command
VAVLE RELAY FDBK	Valve relay feedback
RETURN PUMP CMD	Return pump command
RETURN PUMP FDBK	Return pump feedback
FL HOLD SOL. CMD	Front left solenoid hold command
FL HOLD SOL. FDBK	Front left solenoid hold feedback
FL REL. SOL. CMD	Front left solenoid release command
FL REL. SOL. FDBK	Front left solenoid release feedback
FR HOLD SOL. CMD	Front right solenoid hold command
FR HOLD SOL. FDBK	Front right solenoid hold feedback
FR REL. SOL. CMD	Front right solenoid release command
FR REL. SOL. FDBK	Front right solenoid release feedback
RL HOLD SOL. CMD	Rear left solenoid hold command
RL HOLD SOL. FDBK	Rear left solenoid hold feedback
RL REL. SOL. CMD	Rear left solenoid release command
RL REL. SOL. FDBK	Rear left solenoid release feedback
RR HOLD SOL. CMD	Rear right solenoid hold command
RR HOLD SOL. FDBK	Rear right solenoid hold feedback
RR REL. SOL. CMD	Rear right solenoid release command
RR REL. SOL. FDBK	Rear right solenoid release feedback

**3. ECU Identification**

Lotus Electro-Hydraulic Unit part number: C132J0007J

Bosch Electro-Hydraulic Unit part number: 0 265 236 143

Bosch ECU Software reference: 6209306030000

**5. Diagnostic Trouble Codes**

<b>DTC</b>	<b>Diagnostic Trouble Code Storage Condition</b>
C0035	Front left wheel speed sensor: Short circuit or circuit open; No signal; Incorrect signal;
C0040	Front right wheel speed sensor: Short circuit or circuit open; No signal; Incorrect signal;
C0045	Rear left wheel speed sensor: Short circuit or circuit open; No signal; Incorrect signal;
C0050	Rear right wheel speed sensor: Short circuit or circuit open; No signal; Incorrect signal;
C0060	Front left outlet solenoid valve circuit malfunction;
C0065	Front left inlet solenoid valve circuit malfunction;
C0070	Front right outlet solenoid valve circuit malfunction;
C0075	Front right inlet solenoid valve circuit malfunction;
C0080	Rear left outlet solenoid valve circuit malfunction;
C0085	Rear left inlet solenoid valve circuit malfunction;
C0090	Rear right outlet solenoid valve circuit malfunction;
C0095	Rear right inlet solenoid valve circuit malfunction;
C0110	Return pump: circuit open or shorted; locked or shorted;
C0121	Valve relay circuit malfunction;
C0161	Brake light switch fault;
C0232	Brake system telltale voltage: high or open circuit; low;
C0245	Wheel speed: sensor erratic signal;
C0245	error;
C0252	Replace electronic control unit;
C0550	Replace electronic control unit;
C0550	Brake system or electronic control unit malfunction;
C0556	Replace electronic control unit;
C0561	Replace electronic control unit;
C0563	Replace electronic control unit;
C0564	Replace electronic control unit;
C0800	Switched battery voltage: high (valve relay) low (valve relay)

For remedial procedures, see Lotus TechCentre display.

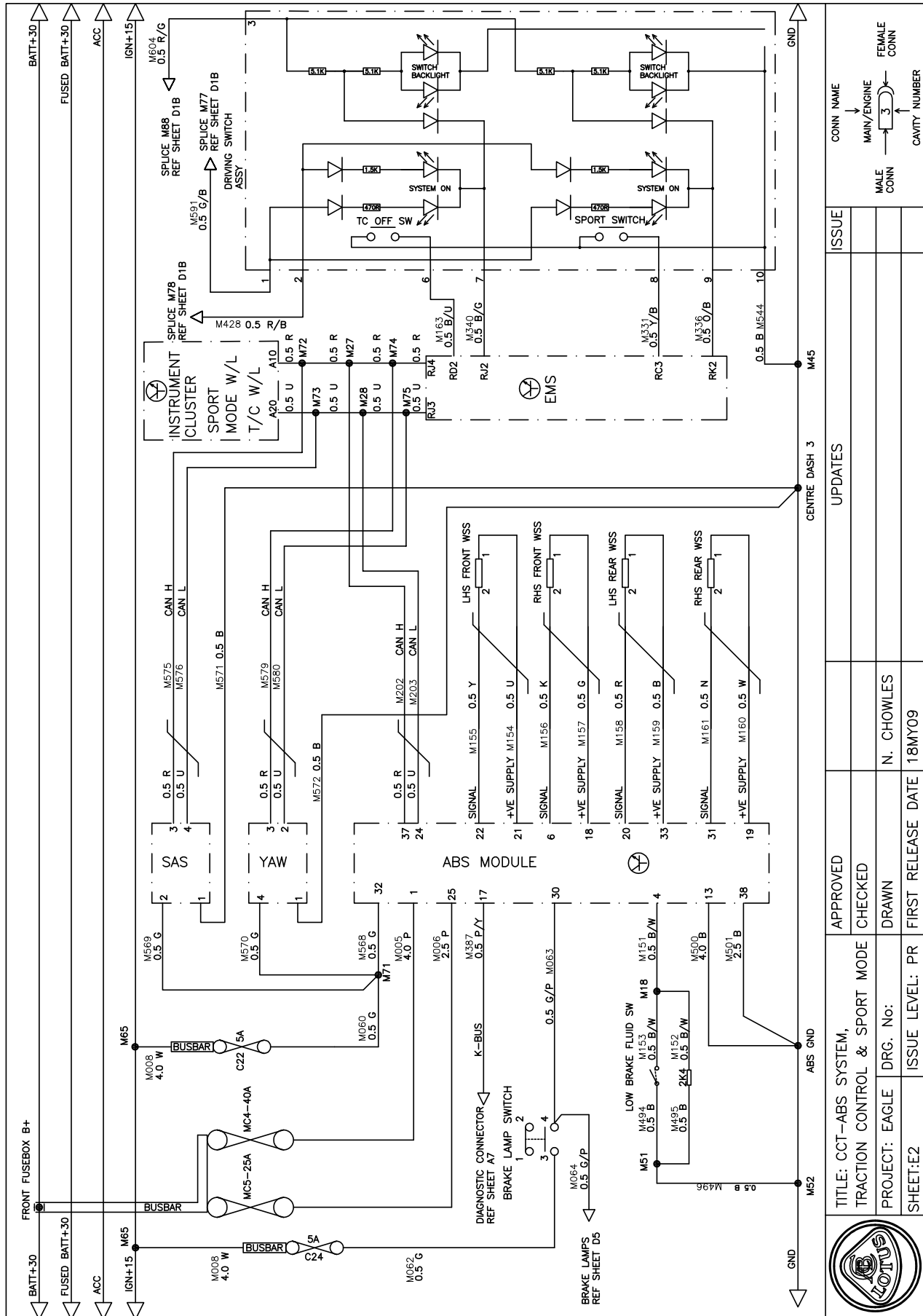



**ENGINE COOLING**

**SECTION KJ**

	<u>Sub-Section</u>	<u>Page</u>
General Description	KJ.1	3
Maintenance	KJ.2	4
Drain/Refill Procedure	KJ.3	5
Radiator & Cooling Fan	KJ.4	6
Radiator Fan & Re-circ. Pump Control	KJ.5	7
Radiator Feed & Return Pipes	KJ.6	7





K76

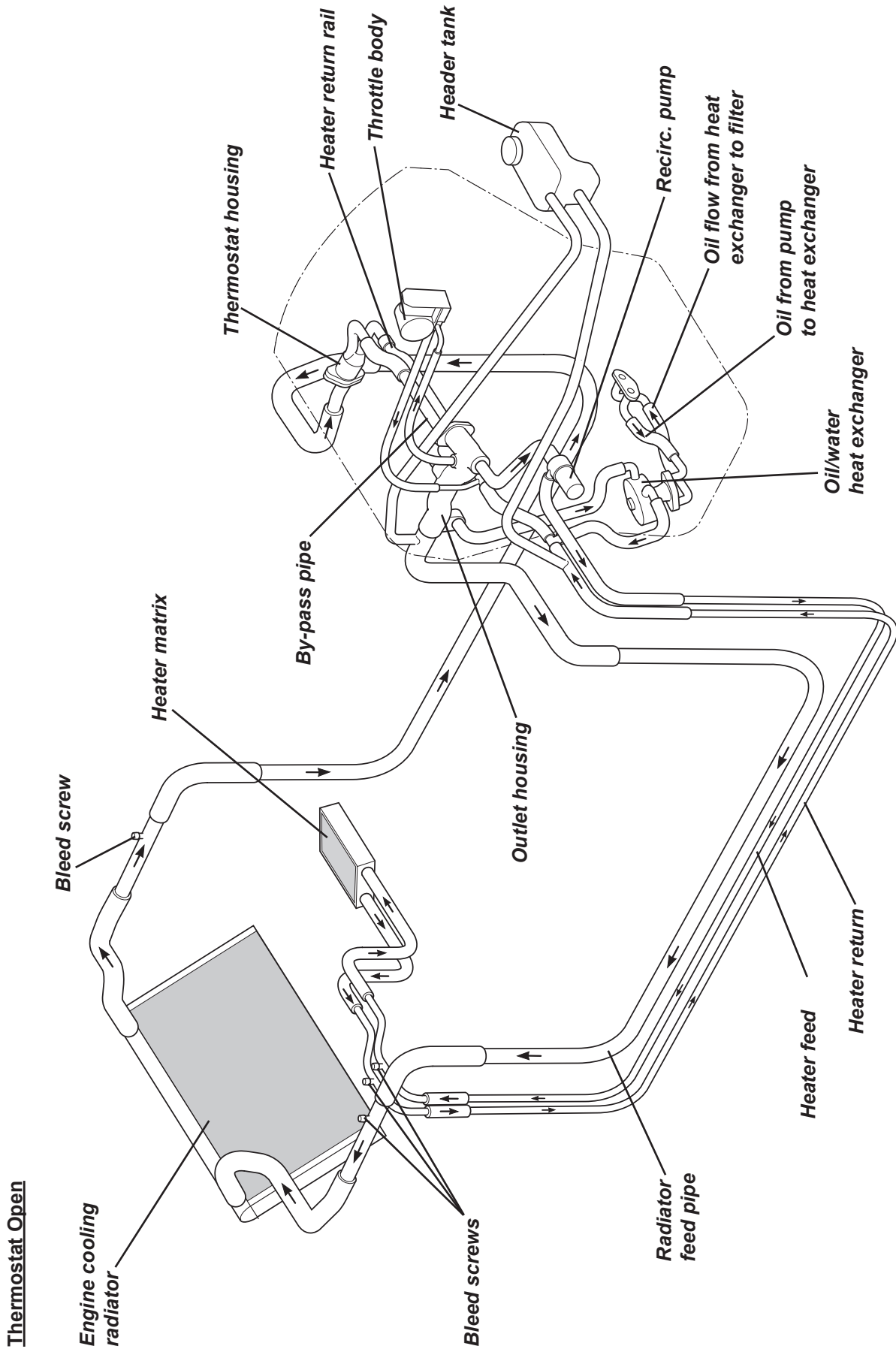



**Thermostat Closed**

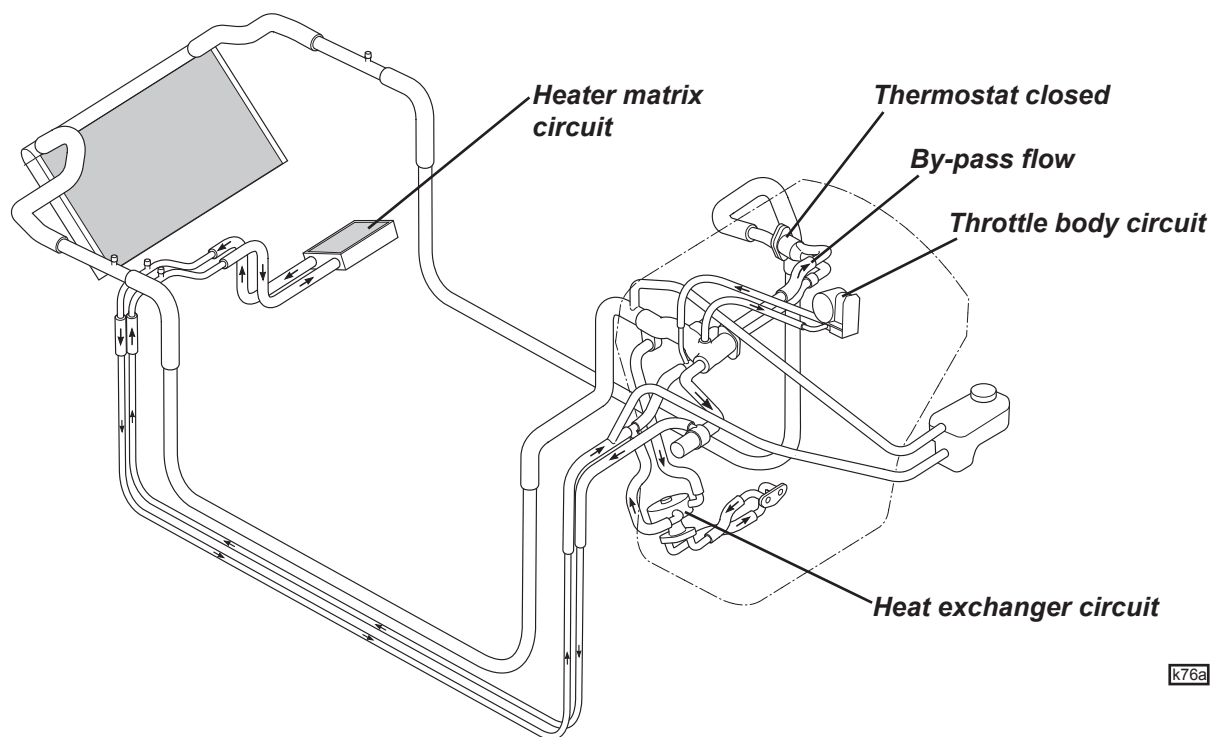

k76a

**KJ.1 - GENERAL DESCRIPTION**

The engine liquid cooling system comprises an engine driven water pump, flow thermostat, front mounted radiator with two electric cooling fans, header tank, re-circulation pump, and associated plumbing.

The centrifugal water pump is mounted on the front face of the cylinder block, and is driven by the multi-rib, serpentine auxiliary belt. The pump discharges coolant into a separate volute chamber for each of the two cylinder banks, where, after cooling the cylinders, flow is directed upwards into each cylinder head before exiting into an outlet housing bolted to the rear of the cylinder heads. From this housing, offtakes are provided for the engine cooling radiator, heater matrix, throttle body, radiator by-pass pipe and, if fitted, an oil/water heat exchanger. A thermostat housing is located on the timing cover above the water pump, and controls the flow of returning coolant from the front mounted radiator.

**Thermostat closed circuit (cold engine):**

At coolant temperatures below 80°C (176°F) the dual valve thermostat is closed, shutting off the return circuit from the radiator and opening a by-pass valve to admit coolant from a by-pass pipe connected to the outlet housing on the rear of the engine. Coolant exiting the cylinder heads meets a closed radiator circuit and is directed through four subsidiary circuits:

*By-Pass:* The greater proportion of flow is via the radiator by-pass pipe back to the engine side of the thermostat housing.

*Heater:* An offtake on the engine outlet housing feeds the heater matrix via a re-circulation pump (see below), pipework running through the RH sill, and a heater by-pass valve mounted to the left of the HVAC unit. Return pipework follows a parallel route and connects to the rear end of the heater return rail. This return rail is routed down the 'V' of the cylinder block, alongside the by-pass pipe, and connects to the engine side of the thermostat housing.

*Throttle body:* A small offtake on the outlet housing supplies a flow of hot water to the throttle body to inhibit ice formation around the valve in severe climatic conditions. An outlet hose from the throttle body connects to heater return rail.

*Oil/water heat exchanger (if fitted):* On cars so fitted, an oil/water heat exchanger is fitted on the LH side of the cylinder block and is fed with engine lubricating oil via feed and return hoses linking to the main bearing



panel. A hose from the engine coolant outlet housing feeds the heat exchanger, with a return hose linking to the heater return circuit. When the engine is cold, heat is transferred from the quickly warming coolant to the engine oil, whilst at high engine temperatures, the temperature managed coolant acts to extract heat from the hotter lubrication system.

### **Thermostat open circuit (normal running temperature):**

At temperatures above 84°C (183°F), the thermostat fully opens the radiator circuit, and closes the by-pass valve.

From the engine outlet housing at the rear of the engine, a pipe running through the left hand sill directs coolant to the single front radiator, rubber mounted between the two longerons of the front subframe and angled forwards at about 45 degrees. The a.c. condenser is mounted ahead of the radiator, to which it is secured by brackets riveted to each sideframe of the radiator. Cooling air is admitted through the front clamshell intake aperture, and exhausted upwards through ducts in the front clamshell ahead of the windscreen, with airflow augmented when necessary by two electric fans, each with 7 curved blades, mounted on the rear face of the radiator. The fans are housed in a plastic shroud which incorporates 12 load relief flaps designed to blow open under ram airflow, and be sucked closed when the fans are operating, in order to maximise fan cooling efficiency. The aluminium radiator core uses moulded plastic top and bottom tanks, with the top tank divided in order to direct the incoming coolant downwards through the LH side, and then upwards through the RH side to the outlet spout. A pipe through the RH sill returns coolant to the thermostat housing on the front of the engine, within which coolant flows through the open thermostat and back into the water pump.

The heater, throttle body and oil/water heat exchanger circuits continue to operate as described above, with a low flowrate through the radiator by-pass circuit.

### **Header tank**

To ensure that the cooling system remains fully filled, whilst providing expansion space for the hot coolant and to facilitate 'topping up' of the system, a translucent header tank is mounted at the LH rear of the engine bay. The tank is connected into the cooling system via a hose which joins into the heater return hose, whilst an air bleed hose from the radiator feed hose near the outlet housing, connects to the air space in the header tank. A threaded, 108 kPa (15 psi) pressure cap is fitted to the neck of the tank.

### **Re-circulation pump**

In order to control engine temperature in conditions of 'heat soak' after stopping a hot engine, an electric re-circulation pump is fitted in the heater take off hose between the engine outlet and heater feed pipework. The pump is enabled for a short period after engine shut down, and is energised under engine ECU control to pump coolant through the heater circuit and limit the potential for localised boiling within the cylinder head. For details of the pump control strategy, refer to sub-section KJ.5

## KJ.2 - MAINTENANCE

The engine cooling system uses a header tank to ensure that the system remains completely filled, and also to accommodate expansion of the coolant with increasing engine temperature. The tank is mounted at the left hand rear of the engine bay, and is fitted with a 108 kPa (15 psi) pressure cap to raise the boiling point of the coolant to over 120°C (250°F).

### **WARNING**

- **Do NOT attempt to remove the pressure cap from the header tank when the engine is warm as serious scalding could result from boiling water and/or steam.**
- **Coolant is hazardous to your health and may be fatal if swallowed.**
- **Keep coolant out of reach of children.**
- **Coolant is hazardous to animals and may be fatal if swallowed. Clean up spilled coolant and do not leave in open containers.**

The level of coolant in the translucent header tank will rise as the engine warms up, and fall as it cools down, and under normal circumstances it should not be necessary to add any coolant to the system between scheduled services. If overfilled, the excess coolant will be expelled when the engine is warm. If underfilled, overheating may result. When the engine is completely cold, and the car is standing on a completely level



surface, the coolant in the header tank should be close to the 'FULL' mark, represented by the horizontal seam running around the tank. The lowest acceptable level is 25mm below the seam.

If topping up is required, wait until the engine has fully cooled before slowly unscrewing the filler cap and allowing any remaining pressure to escape before finally removing the cap.

In order to maintain protection from freezing damage and metal corrosion, use only an approved coolant mixture (see below) to top up the header tank to the 'FULL' mark. Refit the cap, and turn clockwise until the tab on the cap engages a detent, at which position an abutment prevents any over-tightening.

**NOTICE:** If the cap is removed when the engine is warm, the coolant may boil and a small coolant loss may occur. The completely cold header tank level should be checked at the first subsequent opportunity.

### Anti-Freeze/Corrosion Inhibitor

It is necessary that the coolant contains an anti-freeze with corrosion inhibitor to protect the engine and heat exchangers from both frost damage, and corrosion of the metallic elements. In order to protect against these dangers as well as raising the boiling point of the coolant, the Evora is factory filled with a 50% concentration of Havoline XLC, which is a mono-ethylene glycol coolant using organic acid technology (OAT) to provide increased corrosion protection compared with conventional coolant additives. A yellow label around the header tank neck identifies the coolant type used. The corrosion inhibiting carboxylic acids in the OAT coolant tend to remain in solution rather than being deposited on the internal surfaces of the cooling system, thus improving heat transfer and extending service life. Havoline XLC is the only recommended coolant product, and at 50% concentration provides freezing protection down to approximately - 40°C. Even in warm climates it is recommended that the concentration is not allowed to fall below 25%, in order to maintain full corrosion protection.

The simplest means of checking the antifreeze concentration is to measure the specific gravity (density) of the coolant at a known temperature, using a hydrometer. The following table provides a general guide:

<b>Concentration</b>	<b>Density @</b>	
	<b>20°C</b>	<b>60°C</b>
25%	1.039	1.020
33%	1.057	1.034
50%	1.080	1.057

The coolant density reflects the effective level of mono-ethylene glycol, and not the level of corrosion inhibitors present, whose effectiveness diminishes over a period of time. The coolant should therefore be renewed every 4 years to ensure optimum corrosion protection.

In areas where the tap water is extremely hard (exceeding 250 parts per million), use of this water will lead to 'furring up' of the system over a period of time. In such areas, distilled, de-ionised or filtered rain water should be used.

### Radiator Fin Cleaning

At service intervals, the matrix of the engine cooling radiator and a.c. condenser should be checked for clogging by insects, leaves and other debris. If necessary, use a water jet from both above and below to clean the fins, taking care not to damage the fragile tubes or distort the finning. At the same time, check the integrity of all cooling system joints, and the condition of all flexible hoses. In snowy conditions, ensure the radiator air exit is cleared of snow before driving the car.

### KJ.3 - DRAIN/REFILL PROCEDURE

Due to the configuration and routing of the cooling system plumbing, there is no satisfactory low point from which the entire cooling system may easily be self drained. A threaded plug is provided on the radiator bottom tank, which will drain the radiator, but little more unless the car is tilted nose down to some extent. For access to the plug, the front undertray must be removed. Each side of the cylinder block is provided with a drain tap, that on the left being near to the back of the a.c. compressor, and on the right, towards the rear end of the block.

If the coolant is to be renewed, draining of the pipework can be assisted by applying a low pressure airline to the header tank filler neck. Note that with ignition off, the heater solenoid shut-off valve is open.

To refill, secure the radiator drain plug, block drain taps and pipework, and fill the system with a recom-



mended coolant mixture (see above) via the header tank. An air bleed plug is located on the heater return hose near its connection with the return rail, and a bleed nipple is incorporated on the by-pass pipe near its joint with the thermostat housing. An additional bleed plug is provided on the radiator feed pipe accessible via a grommet in the LHF wheelarch liner. All bleeds should be opened until a steady stream of coolant flows from each. Start the engine and allow to idle, and periodically open the bleed plugs to allow any trapped air to be expunged. Top up the header tank when necessary, and fit the pressure cap when required to prevent overflow. When the cooling fans have cut in and then out, stop the engine and allow to cool. Re-check coolant level when fully cold.

### KJ.4 - RADIATOR & COOLING FANS

The engine cooling radiator, a.c. condenser and cooling fans are secured together as a package and are mounted between the two longerons of the front subframe, angled forwards at about 45°, condenser lowermost, radiator above and the two cooling fans on the top side of the radiator. The radiator uses an aluminium core, with tubes running vertically between the top and bottom plastic tanks, the upper tank housing both inlet and outlet spouts and an internal midpoint division, in order to provide a 'U' flow route for the coolant and optimise radiator cooling performance. To protect the radiator structure from potentially damaging vibrations and road shocks, the radiator is provided with two spigots on the bottom tank, and a spigot at the top of each sideframe, with each spigot engaging into a rubber mounting grommet contained in a bracket bolted to the subframe.

#### **Radiator Fans**

Mounting rails for the cooling fan cowling run across the top and bottom of the rear face of the radiator, being secured by screws to the radiator sideframes, with forward extensions to carry the a.c. condenser by a single screw at each corner. Each of the two fan motors is secured to the moulded cowling by four screws, but cannot be removed from the cowling without first releasing the fan from the motor shaft, which operation requires that the cowling be removed from the radiator.

Removal of the radiator exit grilles from the front clamshell provides access to the fan harness connectors for diagnostic purposes, but for fan motor or radiator removal, it is necessary to remove the front clamshell.

To replace:

1. Remove the front clamshell (see sub-section BV.4).
2. Unplug both fan harness connectors.
3. Release the six caphead screws securing the fan cowling to the radiator rails, and withdraw complete with the two motor assemblies.
4. Withdraw the fan from the motor shaft and release the four screws securing the fan motor to the cowling.
5. Refit in reverse order to removal.

#### **Radiator**

To replace: If only the radiator is to be replaced or serviced, it is possible to leave the a.c. condenser *in situ* to avoid the requirement to recover the refrigerant:

1. Remove the front clamshell (see sub-section BV.4)
2. Remove the front undertray and radiator lower duct (note; front fixings to bumper are slotted).
3. Remove the drain plug from the radiator bottom tank, and collect coolant.
4. Disconnect inlet and outlet hoses from the radiator top tank.
5. Unplug the harness connector plug to each of the fan motors.



6. To avoid the requirement to recover the refrigerant, **provide alternative support** before releasing the 4 fixings securing the a.c. condenser to the radiator; ensure that the a.c. pipes and unions are not stressed.
7. Release the two brackets securing the top of the radiator to the subframe and ease the spigots on the bottom tank from its mounting grommets. Withdraw the radiator and fan motor assemblies from the car.
8. Refit in reverse order to removal, and refill the cooling system (see sub-section KJ.3).

## KJ.5 - RADIATOR FAN & RE-CIRC. PUMP CONTROL

The two cooling fans are fitted on the top side of the radiator/condenser package, and the coolant re-circulation pump is mounted at the top left hand rear of the engine, plumbed into the heater feed circuit. Both the fans and pump are controlled by the engine management ECU using data provided by the engine coolant temperature sensor and a.c. pressure sensor.

### **Cooling Fans Control**

The cooling fans are switched as a pair, and will operate at half speed (connected in series) when coolant temperature reaches 98°C on rise (94°C with a.c. on), and switch off at 96°C on fall (92°C with a.c. on). If coolant temperature rises to 105°C (96°C with a.c. on), the fans will switch to full speed (connected in parallel), reverting to half speed on fall at 98°C (94°C with a.c. on).

Note that the temperatures displayed on the instrument panel may differ from the programmed values described above due to damping lag.

The fans are also activated by signals received from the air conditioning pressure sensor; the fans will run at low speed for pressures between 13 - 18 bar, and at high speed for pressures over 18 bar.

Certain types of ECU detected engine fault will also cause the fans to be activated as an engine protection measure. If the ECU receives a coolant temperature sensor signal voltage outside of the acceptable range, a default setting equating to 60°C will be substituted, and the cooling fans will run at half speed.

### **Re-circulation Pump**

A coolant re-circulation electric pump is mounted on a bracket fixed to the underside of the intake airbox, and is plumbed into the heater supply line close to the coolant outlet housing at the LH end of the engine. When energised, the pump circulates coolant through the heater system, drawing coolant from the cylinder head, and pumping it through the heater matrix and back to the engine.

### **Heat Soak**

After ignition switch off, the ECU remains live for a minimum period of 1 minute for coolant temperatures below 75°C (at time of switch off), extending progressively to a maximum period of 10 minutes for temperatures over 90°C. If, during this period, the coolant temperature exceeds 110°C, the re-circ. pump will be activated and will run for a maximum period of 6 minutes, or until the coolant temperature falls to 50°C.

If, during the ECU live period the coolant temperature rises to 120°C, the cooling fans will run at slow speed in addition to the re-circ. pump, for a maximum period of 2 minutes, or until the temperature falls to 70°C.

### **Defrost Enhancement**

In order to speed windscreen defrosting/demisting, when coolant temperature is between 2°C and 60°C, the re-circ. pump will be activated to boost coolant circulation through the heater matrix, commencing 10 seconds after engine start up. The pump will continue to run until 30 seconds after either 1400 rpm is exceeded, or the coolant reaches 60°C.

## KJ.6 - RADIATOR FEED & RETURN PIPES

For both the feed and return circuits between the engine and radiator, two alloy pipes are utilised, one routed together with other pipework, along the outside of the chassis main siderail (feed on left, return on right), within the composite body sill moulding, and one pipe over the wheelarch area to link the front end of the sill pipe with the radiator. No joints are incorporated in the sill sections, where the pipes are supported in foam blocks



clamped to the chassis side. Access to the joints at each end of the sill pipes is available with the appropriate wheelarch liner removed.

Replacement of a sill pipe is not possible without removing or cutting the body sill which is bonded to the chassis. Such a pipe replacement should not however be necessary unless accident damaged together with the body sill.

For full access to the wheelarch area pipes, the front clamshell must be removed.



**FUEL SYSTEM**

**SECTION LN**

	<u>Sub-Section</u>	<u>Page</u>
General Description	LN.1	3
Fuel Requirement & Filling	LN.2	4
Precautions	LN.3	5
Fuel Pump/Sender Assembly	LN.4	6
Fuel Tank	LN.5	7
Fuel Supply Test	LN.6	8
Charcoal Canister	LN.7	8





Evora Fuel System Layout

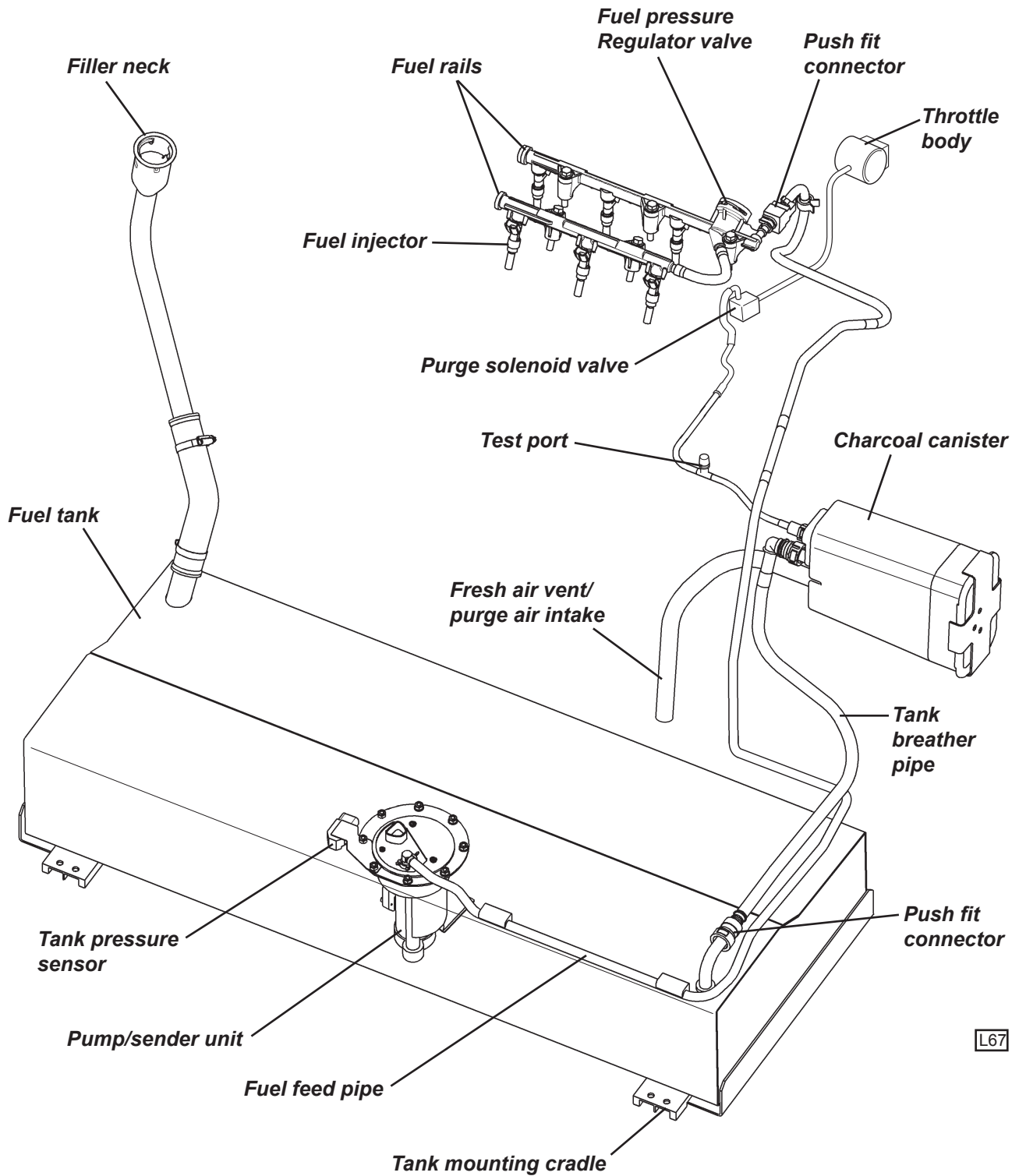

L67



### LN.1 - GENERAL DESCRIPTION

The 60 litre fabricated stainless steel fuel tank is mounted within an open bottomed chassis crossmember ahead of the engine bay and beneath the floor of the cabin rear compartment. The fuel filler neck is connected to the RH rear corner of the tank, with a breather connection at the LH front corner, and the pump/gauge sender unit mounted centrally in the front upper surface, accessible via removeable panels in the body floor and chassis.

In order to meet stringent vapour emissions legislation, various components are housed within the tank, and include the pump assembly and filter, a fill level vent valve, and two gradient vent valves. The pump assembly supplies fuel to the engine fuel rail at a controlled pressure using a non-circulation system.

Inside the tank, a spring loaded flap at the bottom of the filler pipe, allows fuel to enter the tank but inhibits fuel surge up the pipe during cornering forces or extreme vehicle attitude changes. During the filling process, tank ventilation is provided by a fill level vent valve (FLVV) mounted within the tank to the left of the pump. The FLVV allows venting of fuel vapour to the charcoal canister via pipework connecting to the tank breather spigot at the left hand front top corner of the tank. When the fuel level reaches the design maximum, a float ball valve shuts off the vent, causing a pressure rise in the filler neck and triggering the nozzle auto-shut off. The float valve will function in a similar manner to reduce fuel spillage in the event of a vehicle roll-over. In order to ensure tank breathing when the car is parked on a side slope with a near-full tank, at which time the FLVV may be closed, a gradient vent valve is fitted at each end of the tank and connected to the same tank outlet spigot. These valves allow a slower rate of vapour escape and also include a low pressure holding valve and roll-over shut-off functionality. Note that with the exception of the fuel pump/sender unit, none of these 'in-tank' components are serviceable other than by fuel tank replacement.

The tank structure incorporates a system of baffles surrounding the pump assembly to ensure that the pump inlet is kept submerged during extreme dynamic forces until the fuel level becomes near empty. The modular fuel pump/gauge sender assembly is mounted inside the tank, clamped to the top surface by eight studs. The pump uses an electric motor to power an integrated turbine, to draw fuel through an intake strainer sock, and pump the fuel through the motor body and a non-return valve, to exit into a filter chamber incorporated into the housing of the pump/sender unit. After the filter, a pressure regulating valve controls the output line pressure to around 3.2 bar, spilling excess fuel back into the tank, and supplying the pressurised fuel to the outlet port on the top surface. A non-recirculation type of fuel feed system is employed in order to minimise evaporative emissions. The feed pipe is routed along the LH top rear of the fuel tank bay to emerge through the chassis beneath a plastic shroud, and thence into the engine bay. The pipe then continues without a joint until connecting to the LH end of the engine rear bank fuel rail, to which the front bank rail is linked by a short connector hose.

When the ignition is first switched on, the engine management ECU energises the fuel pump for a period of about 3 seconds to prime the system before switching off. If a signal from the crankshaft sensor indicates that the engine is being cranked or is running, the fuel pump feed will be maintained. The pump is switched off immediately the ignition is turned off, or about 3 seconds after a stall. Note that after the ignition is turned off, the ECU will remain live for up to 20 minutes (dependent on coolant temperature), to allow for heat soak management (see sub-section KI.5).

A safety inertia switch is incorporated into the fuel pump electrical circuit, and operates in a severe impact (indicative of a vehicle collision) to switch off the fuel pump feed and minimise the fire risk. The doors will also be unlocked. The switch is mounted on the seat belt mounting frame LH backstay, accessible from the engine bay, and is reset once tripped, by pressing the rubber button on the top of the switch.

An evaporative emissions 'charcoal' canister is mounted at the LH side of the engine bay bulkhead, beneath the air intake duct, and is connected to the tank by a moulded tube. The plastic shroud covering the fuel pipes in the cabin rear compartment, incorporates a removeable plate to allow access to the breather pipe connection to the tank. The purge port of the canister is connected to a solenoid valve mounted on the LH end of the front bank cam cover, and thence to the intake plenum just downstream of the throttle body. The evaporative emissions control system prevents untreated fuel vapour from the tank reaching the atmosphere, by absorbing the tank vapour in a bed of activated charcoal in the canister. When the engine is running, the engine management ECU opens the purge solenoid valve by duty cycle, and allows intake manifold depression to draw fresh air through the canister via a third port on the canister, purging absorbed fuel from the charcoal, and consuming the resultant vapour in the normal combustion process. In this way, the charcoal bed is 'cleaned' ready to absorb more tank vapour when the engine is stopped.



## LN.2 - FUEL REQUIREMENT & FILLING

### **Fuel Requirement**

Use only premium grade UNLEADED fuel with a minimum octane rating of 95 RON. Using fuel with a lower octane rating may cause knocking (pinking) which, if severe, can cause serious engine damage. Light knocking may occasionally be heard for short periods when accelerating or driving up hills, and should cause no concern, although using a lower gear would be advised. If, however, persistent heavy knocking is heard when using the specified fuel, a fault is indicated.

If no unleaded premium grade fuel is available, 91 RON unleaded fuel may be used for short periods, but heavy engine loads and wide throttle openings must be avoided. The use of good quality fuels containing proper detergent additives is advised for good performance and emission control.

The Evora is fitted with 'three way' catalytic converters in the exhaust system in order to reduce the noxious content of the exhaust gases and comply with emission control regulations. It is essential that ONLY UNLEADED FUEL is used. The effectiveness of the catalytic converters decreases after as little as one tankful of leaded fuel or LRP.

### **Note**

- The use of leaded fuel, or lead replacement petrol (LRP), will cause irreversible contamination of the precious metal catalysts and of the exhaust gas sensors used by the computer controlled engine management system.
- Fuel system damage and running problems, resulting from the use of incorrect fuels will not be covered by your New Vehicle Warranty.
- DO NOT push or tow start the car; or turn off the ignition at engine speeds above idle; or run the fuel tank dry: Any of these actions may damage the catalytic converters.

*Ethanol E5 & E10* - A mixture of 5% or 10% ethanol (grain alcohol) and unleaded petrol may be used in the Evora but the lower octane rating (typically 93 - 94 RON) will result in slightly reduced performance and economy. If driveability problems are experienced as a result of using ethanol, use 95 RON unleaded petrol. Do not use Ethanol blends with a higher concentration than 10%.

*Methanol* - Do not use fuels containing methanol (wood alcohol). Use of this type of alcohol can result in performance deterioration and damage to critical parts in the fuel system.

*Fuels Containing MMT* - Some fuels contain methylcyclopentadienyl manganese tricarbonyl (MMT), which is an octane enhancing additive. Such fuels may damage the emission control system and should NOT be used.

*Diesel* - The Lotus Evora will not operate on diesel fuel.

### **Fuel Filling**

#### **WARNING:**

- **Be aware of the danger of explosion when dealing with petrol and its attendant fumes. Before stopping at a filling station, switch off mobile phones, ensure that all cigarettes are extinguished and that no naked flames or other potential ignition sources are present.**
- **Switch off the engine before refuelling.**
- **Remove the filler cap slowly to allow any pressure to bleed off gradually. Hasty removal may result in a small amount of fuel spray with a possible health or fire hazard.**

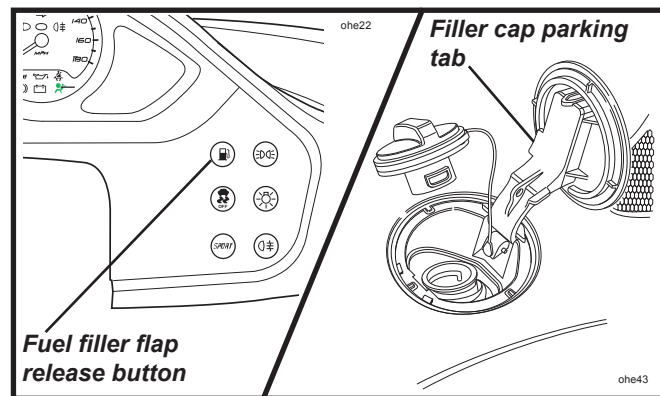

**Filler Cap:** The fuel filler is located in the right hand rear quarter panel, concealed by a flush fitting hinged flap. To open the flap, press the release button in the fascia panel outboard of the steering column, with or without the ignition key in position, and the flap will spring fully open. Unscrew the filler cap. As the cap is turned, any pressure differential between the tank and the atmosphere will be released and a brief hiss may be heard. Allow the pressure to equalise gradually to avoid the potential for a small amount of spray. Note that the cap is tethered to prevent its loss, and should be hooked onto a tab provided for this purpose, on the hinge of the flap.

To refit, place the cap into the filler neck and turn clockwise until the ratchet mechanism clicks several times. Push the flap closed.

**Filling Procedure:** Insert the pump nozzle fully into the neck, and fill until the auto-shut off mechanism is triggered. Do not attempt to 'brim' the tank to the top of the filler neck, as expansion of the fuel due to temperature change (e.g. cold underground fuel storage) may cause flooding of the fuel tank breather system charcoal canister, or spillage of fuel.

The total usable fuel capacity is 60 litres (13 imp.gal), but for re-fuelling purposes, from the time the low fuel tell tale is triggered, approximately 50 litres can be accommodated. Note that from the point of low fuel tell tale activation to the gauge reading empty, is around 5 litres.

**Note:** The remaining balance of approx. 5 litres, should be treated only as an emergency contingent, the use of which may entail intermittent fuel starvation dependent on driving conditions, and potential engine damage. In such a situation, driving style should be modified to minimise engine load and cornering forces.

If maximum engine or handling performance is to be exploited, or severe gradients tackled, a high fuel level should be maintained to ensure the greatest safety margin of fuel supply.

## LN.3 - PRECAUTIONS

The fuel line between pump and injector rail, and the injector rail itself, contain pressurised fuel both when the ignition is switched on, and for a period after switching off. This feature aids engine starting by reducing the time needed to build up operating fuel pressure, and by inhibiting the formation of vapour pockets in the supply line after switching off a hot engine.

### **WARNING:**

- i) **To minimise the risk of fire and personal injury, relieve the fuel system pressure before servicing any part of the fuel supply circuit. See 'Fuel Pressure Relief Procedure' below.**
- ii) **To reduce the possibility of sparks occurring when a fuel line is disconnected, or when fuel vapour is present, the negative battery cable should be disconnected before work is commenced.**
- iii) **When fuel lines are disconnected, absorb any escaping fuel in an absorbent cloth and dispose of safely.**

### **Fuel Pressure Relief Procedure**

This procedure should be used prior to disconnecting any part of the fuel line.

- Remove the fuel pump fuse R19, start the engine, and run until it stops from starvation. Crank the engine for a further few seconds.



- If the engine is a non-runner, pull out the fuel pump fuse, and crank the engine for 20 seconds to minimise residual fuel pressure.
- Disconnect the battery.
- The hose connecting the fuel tank to the fuel rail has no joints other than the push-on connectors at each of its ends. For access to the fuel tank connection, the cabin rear compartment floor must be removed, followed by the body and chassis access hatches. To access the fuel rail connection with the clamshell fitted, it is necessary to remove the airbox.
- Surround the pipe joint with a shop towel to absorb fuel contained in the pipework before pressing the release buttons and separating the joint.

**WARNING: Be aware of the possibility of full pressure retention in the fuel line caused by a system fault.**

- On re-fitting, push the joint firmly together until a click is heard. Pull on the pipe to ensure complete engagement.

### LN.4 - FUEL PUMP/TANK SENDER

The fuel pump/gauge sender unit is mounted centrally in the front upper surface of the fuel tank, accessible via removeable panels in the cabin rear compartment body floor and chassis. The modular fuel pump/gauge sender assembly is mounted inside the tank, clamped to the top surface by eight studs. The pump uses an electric motor to power an integrated turbine, to draw fuel through an intake strainer sock, and pump the fuel through the motor body and a non-return valve, to exit into a filter chamber incorporated into the housing of the pump/sender unit. After the filter, a pressure regulating valve controls the output line pressure to around 3.2 bar, spilling excess fuel back into the tank, and supplying the pressurised fuel to the outlet port on the top surface. A non-recirculation type of fuel feed system is employed in order to minimise evaporative emissions. Note that for some markets, a fuel tank pressure sensor for on-board diagnostics is fitted alongside the pump/sender in the tank top surface.

The fuel gauge sender is mounted on the side of the pump housing, and uses a float on a pivoted arm to operate two rheostat strips supplying fuel level data to the engine ECU.

#### **To remove/refit fuel pump assembly**

1. De-pressurise the fuel system (see sub-section LN.3).
2. Remove the cabin rear compartment floor covering, and the access panels in the body and chassis. Using an absorbent cloth to collect residual fuel, slide the yellow retaining clip aside and withdraw the pipe from the pump spigot.
3. Unplug the harness connector to the pump and pressure sensor (if fitted).
4. Release the 8 fixings and withdraw the securing the clamp plate, noting the position of the earth lead.
5. Taking suitable precautions to catch any dripping fuel, carefully withdraw the pump assembly from the tank aperture, taking care not to damage the delicate float arm, strainer sock, or other vulnerable parts.
6. *Fuel pump:* If necessary, the fuel pump may be removed from the housing by unclipping the yellow retainer, removing the rubber cushion, unplugging the harness connector, and withdrawing the pump.
7. Before re-fitting, ensure that the strainer sock is clean, replacing if necessary, and using a new retaining clip. Note that the non-return valve is incorporated into the outlet spout of the pump, and is not individually replaceable.
8. *PRV:* The pressure regulator valve may be replaced after unclipping the yellow retainer from the base of the housing, and withdrawing the valve.
9. *Level sender:* The fuel level sender unit may be removed from the housing by unplugging the connector,



depressing the retaining barb behind the resistor block, and sliding the block downwards.

10. Before re-fitting the assembly back into the tank, ensure that all connector plugs are secure, and that the top sealing ring is in good condition. To aid subsequent removal, apply a dab of MoS2 grease to each of the retaining studs on the tank before fitting the pump assembly. Feed the unit through the tank aperture and fit the retaining ring over the eight studs. Note that the cut out and dowel holes in the clamp plate define its orientation in respect to the pump. A flat on the clamp plate must align with the front edge of the tank.
11. Fit the earth cable onto the stud positioned at 4 O'clock as viewed from behind. Fit all fixing nuts and nip tighten to 2 Nm in a diagonal sequence before final tightening to 5 - 6 Nm. Ensure the yellow clip is securely engaged with the fuel supply pipe connector.

### LN.5 - FUEL TANK

The 60 litre fabricated stainless steel fuel tank is mounted within an open bottomed chassis crossmember ahead of the engine bay and beneath the floor of the cabin rear compartment. The fuel filler neck is connected to the RH rear corner of the tank, with a breather connection at the LH front corner, and the pump/gauge sender unit mounted centrally in the front upper surface. The tank is clamped into position by a pair of extruded alloy cradles incorporating transverse restraints, bolted fore/aft across the underside of the chassis bay, with the tank located and protected by a set of foam strips and pads interposed between the tank and chassis.

#### **Fuel tank removal/refit**

This operation is most easily and safely performed when the fuel level is lowest. If this is not possible, it is recommended to pump out the fuel into a suitable container in order to minimise the tank weight.

1. De-pressurise the fuel system (see sub-section LN.3).
2. *Top connections:* Remove the cabin rear compartment floor trim. Remove the central access panel and disconnect the fuel feed pipe and harness connector from the tank. Plug the fuel tank port. Remove the access panel at the left hand side of the compartment, and disconnect the beather pipe from the tank. Plug the tank port.
3. *Filler hose:* From inside the car, remove the rear bulkhead access panel, and release the filler hose from the filler neck, and seal the hose. Also release the fuel tank earth cable from the chassis stud at the right hand front of the engine bay
4. *Undershield:* Remove the 26 fixings and remove the fuel tank undershield.
5. *Parking brake cable:* Release the parking brake primary cable from the secondary cables, and free from any chassis fixings.
6. *Gearchange cables:* Release the gearchange cables from the chassis fixings to provide sufficient slack to allow tank withdrawal.
7. *Cradles:* Provide alternative support for the tank before releasing the four screws from each of the two tank retaining cradles. Lower the tank from the chassis.
8. *Refitting:* Before refitting the tank, ensure that all the foam pads are in position and secure on either the chassis or tank, and renew if necessary. Check that all apertures are sealed. Check that the fuel feed pipe is in position along the front of the tank bay.
  - Carefully raise the tank into position and ensure that it is firmly in contact with the front pad.
  - Fit the retaining cradles using Permabond A130 (A912E7033V) on the bolt threads, and torquing to 24 Nm.
  - Continue in reverse order to removal.



## LN.6 - FUEL SUPPLY TEST

### **To Test Fuel Pump Output**

Fuel pressure is controlled by the fuel pump and pressure regulator valve. Delivery may be checked at the connection to the fuel rail after de-pressurising the system and using a proprietary fuel pressure gauge.

The procedure for testing fuel pressure, set by the pressure regulator valve on the end of the fuel rail, is detailed in section EM. Base fuel pressure is 3.0 bar. If the result of this test is satisfactory, the fuel pump delivery quantity may be checked as follows:

**WARNING: Take all necessary precautions to guard against fire and explosion risk when dealing with fuel and fuel vapour.**

1. Disconnect the fuel rail return line (e.g. at quick fit connector), and arrange for collection of return fuel into a suitable container.
2. Arrange for an auxiliary 12 volt feed to the fuel pump to allow continuous operation.
3. Run the pump for one minute and measure the fuel quantity delivered.  
Specification = 2.0 - 2.8 litres.  
If below specification, check the fuel filter for restriction before replacing the fuel pump.

### **To Remove Pump/Sender Assembly**

1. Remove the fuel tank (see sub-section LN.4).
2. Release the circlip securing the pump assembly into the tank top flange, noting that the unit is lightly spring loaded, and withdraw the unit and sealing 'O' ring. Take suitable precautions to catch any dripping fuel. Cap the tank aperture to prevent dirt ingress and to reduce the fume hazard.
3. To release the fuel gauge sender unit, unclip the black foot from the base of the canister, and disengage the sender mounting bracket from the canister. Disconnect the electrical cables from the unit and withdraw. Take care not to damage the float arm.
4. For access to the pump, depress the three retaining barbs, and withdraw the reservoir canister from the pump assembly. Unplug the pump electrical connector, and pull the pump from its outlet spigot.
5. Thoroughly clean the fuel inlet strainer socks on the pump and canister before refitting.

### **Re-fitting Pump/Sender Assembly**

Fit the pump assembly into the tank aperture using a new 'O' ring, and locate the positional tab on the pump top plate in the tank flange slot. Retain with the circlip. Refit the fuel tank and 'shear' panel.

## LN.7 - CHARCOAL CANISTER

In order to prevent fuel vapour venting from the fuel tank to atmosphere, the breather pipe from the tank is routed to a canister filled with activated-charcoal, which absorbs and stores the fuel vapour when the engine is stopped. When the engine is running, the canister is connected to the depression in the intake plenum such that fresh air is drawn through the canister to purge the charcoal of its absorbed fuel, with the resultant gas then consumed by the engine in the normal combustion process.

### **Charcoal Canister**

This is mounted on the bulkhead at the left hand front of the engine bay, oriented horizontally with its base to the left, located in a socket bracket, and its top, which houses the three pipework connections, to the right and secured to another bracket by a single M6 screw. Access to the unit is available after removal of the airbox intake trunking.

The right hand end of the bed is ventilated via the lowermost port marked 'AIR', to which is attached a length of rubber hose routed down the front of the engine bay. The breather pipe from the fuel tank uses a



press button quickfit connector to join to the mid-positioned spigot on the canister marked 'TANK', within which the port is extended to the far end of the charcoal bed. In this way, vapour from the fuel tank is cleansed of fuel by the charcoal bed before being vented.

A second quickfit type connector is used on the purge pipe spigot positioned uppermost and marked 'PURGE', and which also communicates with the left hand end of the bed. The external pipe from this port incorporates a service test connector before joining the purge solenoid valve mounted on the rear end of the LH camshaft cover. The outlet pipe from this valve connects to the engine intake plenum just downstream of the throttle valve. The solenoid valve is opened during certain engine running conditions in order to allow intake depression to draw fresh air through the vent pipe and charcoal bed, cleansing the charcoal of fuel before consuming the resultant vapour in the normal combustion process. In this way, the charcoal is prepared for further vapour absorption when the engine is stopped.

### **Control System**

The canister purge valve is controlled by the engine management ECU, which keeps the valve closed (unenergised) when the engine is cold or idling in order to protect the catalyst and maintain idle quality. At normal running temperatures and engine speeds above idle, the ECU monitors other parameters and sensor data and when appropriate conditions pertain, the ECU will apply a duty cycle to the valve in order to regulate the amount of purging allowed, so as not to corrupt the smooth running of the engine.





ELECTRICS

SECTION MR

	<u>Sub-Section</u>	<u>Page</u>
PFK 457 Vehicle Security Alarm	MR.1	2
Central Door Locking	MR.2	6
Electric Windows	MR.3	7
Door Mirrors	MR.4	8
Switches & Instruments - Driver's Information	MR.5	10
Component Location & Fuse Ratings	MR.6	23
Audio Equipment	MR.7	27
Battery, Battery Cables & Earthing Points	MR.8	28
Wiper Mechanism	MR.9	29
Harness Routing	MR.10	30
Headlamp Assemblies	MR.11	31
Bulb Replacement	MR.12	32
Instrument Panel	MR.13	33
Circuit Diagrams	MR.14	34



## MR.1 - PFK 457 VEHICLE SECURITY ALARM

### Keys

A mechanical key is used to operate the combined ignition switch/steering column lock, and the emergency manual door locking function via the left hand door. The keyhead incorporates three push buttons by which to operate the electronic immobiliser, alarm system and central door locking.

A duplicate key is supplied with the new car and, on receipt, should be separated and kept in a safe place for use in an emergency. The mechanical key code and security system PIN (sPecific Identification Number) are also supplied with the keys, and should be removed from the key ring by the owner, and noted safely with the vehicle documents. These numbers should also be recorded by the selling dealer and kept securely with the vehicle file in the interests of customer service. The codes will be required when ordering or programming replacement or additional keys, and the PIN will allow the security system to be overridden in case of transmitter loss or failure (see later).

### Vehicle Security Alarm

The Lotus Evora is fitted as standard with a PFK 457 immobiliser/alarm which includes the following features:

- U.K. approval to Thatcham category 1.
- 'Dynamic coding' of the transmitter keys; Each time the transmitters are used, the encrypted rolling code is changed to guard against unauthorised code capture.
- Passive activation of immobiliser, central locking and alarm system.
- Ingress protection using sensing switches on the latches of both doors, and the tailgate.
- Selectable cockpit intrusion detection using a microwave sensor.
- Self powered siren to maintain protection if the vehicle battery is disconnected.
- Personal protection by 'on demand' activation of the siren.
- Emergency alarm override and transmitter key programming using an alarm sPecific Identification Number (PIN).
- Homesafe and selectable dynamic (drive away) locking.

### Transmitter Keys

Two transmitter keys are provided with the car, and combine a mechanical key blade with a three button transmitter unit incorporated into the key head. The mechanical key operates the ignition switch/steering lock and emergency manual door locking. The transmitter operates the central locking, alarm system and electronic immobiliser. The 4-digit code for the mechanical key, the unique serial number of the immobiliser/alarm, and the system's 5-digit sPecific Identification Number (PIN), are supplied on plastic tags attached to the key ring of a new vehicle.

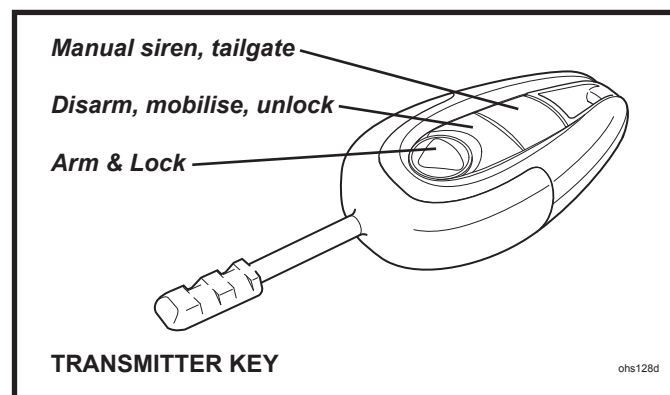

### Disarming the Alarm/Unlocking

When approaching the car, it is likely that the vehicle is locked and the alarm armed, as indicated by the alarm red tell tale lamp in the speedometer face flashing once every 3 seconds. To disarm the alarm and unlock the doors:

- Press the central, unlock, button on the transmitter key. The first press will unlock the driver's door, and a second press, the passenger's door.
- This command will be acknowledged by a double flash of the hazard lamps.
- The alarm tell tale will be extinguished.
- The interior and mood lights will fade on, and remain lit for up to 2 minutes (if set to the 'courtesy' position).
- The engine will be mobilised (see below).



## Auto Re-arm

If a door is not opened and closed within 2 minutes of a disarming command, the doors will passively re-lock and the alarm system re-arm.

## Passive Immobilisation

In order to provide a measure of automatic vehicle security, independent of any driver initiative, the system will automatically immobilise the engine's cranking and fuel pump circuits after the ignition has been turned off for 40 seconds, or a similar period has elapsed since the last mobilising command. With the ignition off, the alarm tell tale will indicate that immobilisation is in effect by a brief flash every 1.5 seconds. With ignition on, immobilisation is indicated by a continuously lit tell tale.

To mobilise the car (i.e. allow engine starting) with ignition on or off, press once the transmitter centre button; the alarm tell tale will be extinguished.

## Arming the Alarm/Locking the Doors

To lock the doors and arm the alarm, remove the ignition key, shut both doors, and check that the tailgate is properly closed.

- Press once the raised logo button on the transmitter key.
- This command will be acknowledged by a single flash of the hazard lamps.
- Both doors will be locked, and after a settling period of 40 seconds, the engine will be immobilised, and the alarm system armed.
- The alarm tell tale will flash once every 3 seconds.
- The interior and mood lamps (if lit) will fade off.

### Note:

- i) If the system is armed when a door is not fully shut, three **triple** beeps will sound as a warning and the doors will not be locked. Opening a door will **not** trigger the alarm.
- ii) If the system is armed when the tailgate is not fully closed, three warning **double** beeps will be heard, and the doors will not be locked. Opening a door in this instance **will** trigger the alarm.

When fully armed, and after the settling period of 40 seconds has expired, the alarm will be triggered by any of the following actions:

- Interruption of the car battery power supply or siren cables.
- Energising the ignition circuit ('hot wiring').
- Opening a door;
- Opening the tailgate;
- Movement detected within the cabin (unless de-selected).

If the alarm is triggered, the hazard warning lamps will flash and the wailing siren will sound for a period of approximately 30 seconds before closing down and resetting, ready for any further triggering input. If a trigger is continuously present (e.g. door left open), the alarm will repeat for a maximum of eight 30 second cycles before excluding the triggering sensor for the remainder of the armed period.

To silence the siren, press once the central, disarm button on the transmitter key. If necessary, press a second time to disarm the alarm. Note that if the vehicle battery has been disabled, it will not be possible to interrupt the siren until completion of the sequence.

## Alarm Tell Tale Summary

Brief flash every 3 secs;	Immobilised, alarm armed.
Brief flash every 1.5 secs;	Immobilised, alarm disarmed, ignition off.
Tell tale on;	Immobilised, alarm disarmed, ignition on.
Tell tale off;	Mobilised, alarm disarmed, ready to start.



## Turning Off the Interior Movement Sensor

A microwave sensor mounted behind the centre console, will detect substantial physical movement within the cockpit, and trigger the alarm.

If an animal is to be left in the vehicle, or if for any other reason it is desired to exclude the interior movement sensor, press once the transmitter logo button in the normal way to set the alarm, and then press a second time (within 2 seconds) to exclude the interior movement sensor. A single beep will be heard as confirmation. The sensor will automatically re-activate next time the alarm is armed.

## Opening the Tailgate

To open the tailgate, press twice the end button on the transmitter key; the latch will release and allow the tailgate to be opened, assisted by pressurised struts. Boot lamps will switch on automatically whenever the tailgate is open.

With the ignition switched on, warning of an open or not fully latched tailgate is provided on the right hand screen in the instrument panel via the vehicle silhouette graphic.

To close the tailgate, ensure that no persons or objects will be trapped before pulling down the panel and pressing firmly over the latch to assure its complete engagement. Guard against inadvertently locking the transmitter key in the boot.

## Manual Activation of Siren

If, for personal security reasons, it is desired to manually activate the siren at any time when the ignition is off, hold pressed the end button on the transmitter key for 3 seconds. The wailing siren will sound, and the hazard lamps flash for a period of 30 seconds. To stop the siren, press once any of the transmitter buttons.

Manual siren activation will not affect the alarm system status.

## Transmitter Key Battery Replacement

The transmitter fobs will normally operate within a range of 5 metres from the car, but this may be reduced by the presence of other radio signals in the vicinity.

The transmitters are powered by a long life 3V Lithium battery, type CR2025, readily available from electrical outlets, which with normal use should last for 3 years. To ensure continuity of operation, it is recommended to renew the batteries every 12 months:

- Using a small screwdriver, prise the transmitter fob from the key blade carrier utilising the slot provided on the back of the case.

- At the end face of the fob, prise the retaining tang inwards whilst withdrawing the battery carriage from the fob.

- Remove the old battery and wait for 10 seconds before inserting a new battery, with +ve sign lowermost, and holding the battery only by its periphery.

- Slide the battery carriage back into the fob, pressing firmly to engage the clip, and then clip back onto the key blade.

- The transmitter should now operate normally.

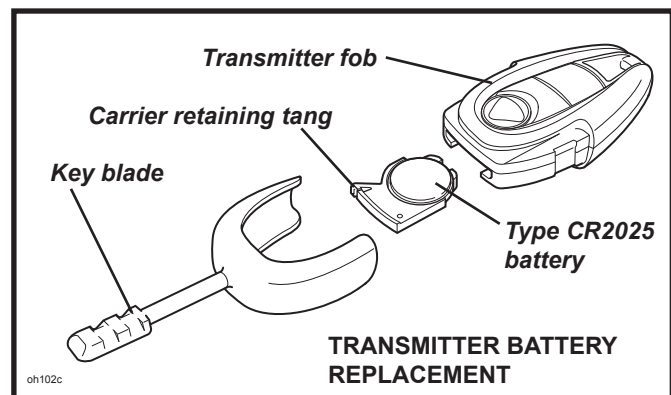

## Emergency Disarming/Mobilising

If the key transmitter is damaged or fails to function, and a spare key is not available, the alarm system's unique sPecific Identification Number (PIN) may be used to disarm the alarm **provided that** access is available to the cabin:

- Turn on the ignition. The alarm tell tale will light.
- If the alarm is armed, accessing the cabin, or turning on the ignition will trigger the alarm until completion of this emergency process.
- Within 10 seconds, turn the ignition off; the tell tale will begin to flash.
- After a number of flashes corresponding to the first digit of the PIN, turn on the ignition. Note that the first flash may not be of full duration (but is still to be counted) dependent on the waveform position at time of ignition switch off. Note that 10 flashes correspond to a zero digit.



- Turn off the ignition and after a number of flashes corresponding to the second digit of the PIN, turn on the ignition. Repeat this process until all 5 digits have been completed. If, at any stage of the process, a number is entered incorrectly, the system will immediately revert to the start, so that the whole PIN must be re-entered.
- If the PIN is entered correctly, the alarm will now be overridden and the engine mobilised. However, automatic immobilisation will still occur after an ignition off time of 40 seconds, requiring a repeat of the above procedure to mobilise. Note that automatic re-arming of the alarm and automatic door locking cannot occur until a working transmitter is used to operate the alarm.

**Programming Additional Transmitters**

Two transmitter fobs are provided with the new car. If one transmitter is lost or damaged, a replacement should be obtained immediately, and programmed to the car alarm controller using the alarm system's unique sPecific Identification Number (PIN). A maximum of 6 transmitters may be programmed to the car, any thereafter overwriting the first to have been programmed.

- With the engine immobilised (tell tale flashes briefly once per second), turn on the ignition.
- Enter the PIN as detailed in the emergency disarming process above, followed by the additional two digits 1, 1.
- The tell tale will flash rapidly for one second, then turn off.
- Within 8 seconds, press any button on the transmitter to be programmed. The tell tale will then pulse rapidly and the siren will beep.
- Within 10 seconds press any button on the next transmitter to be programmed (if applicable), and repeat this process for all remaining transmitters.
- When all transmitters have been programmed, wait for 10 seconds, or turn off the ignition.

To disable a lost or stolen transmitter from the system, use the above procedure to programme 6 transmitters, if necessary repeatedly reprogramming the same transmitter if less than 6 programmed transmitters are to be used.

**Disconnecting the Car Battery**

In order to prevent the alarm being triggered, before disconnecting the vehicle battery, ensure that the alarm is disarmed.

**Trigger Report Back and Feature Selection**

A facility is provided to identify the source of an alarm triggering event (trigger report back), as well as allowing certain features of the system to be selected or de-selected. The same procedure described above to input a PIN is used, but in this case to input the programming code '123'; the tell tale will then flash rapidly for 1 second, then remain lit. Commencing within 10 seconds, continue this procedure to input the two digits of the feature code, after which the tell tale will flash rapidly for 1 second then beep once or twice to indicate the new status of that feature; one for 'ON', twice for 'OFF'. Selection will alternate each time that feature code is entered. Note that within 10 seconds, a second feature code (or repeat) may be selected from this point by entering only the 2-digit code. To exit programme mode, simply wait for 10 seconds.

<i>Feature</i>	<i>Code</i>	<i>Default</i>	<i>1 Beep</i>	<i>2 Beeps</i>
Revert to defaults	123 00			
Trigger report back	123 11	see below		
Unlock with ignition	123 33	OFF	ON	OFF
Lock with ignition	123 34	OFF	ON	OFF
Selective door unlock	123 41	ON	ON	OFF
Audible tones*	123 61	OFF	ON	OFF
Lock with auto re-arm	123 87	ON	ON	OFF
Door open audible warning	123 88	ON	ON	OFF

\* When selected, a single beep will sound when the alarm is armed, and a double beep when disarmed. To silence for a single activation, press briefly the transmitter auxiliary (3rd) button prior to pressing the arm or disarm button.



*Trigger report back:* After the code 12311 has been entered, the tell tale flashes out a code(s) to indicate the source of the alarm trigger:

No. of flashes	Triggering sensor
1	Microwave movement sensor
2	Door, bonnet or boot lid
3	Ignition energisation
4	Manual siren activation

### Quick Test

To facilitate testing of the alarm system, the unit can be placed into a 'Quick Test' mode by arming the alarm with one transmitter key, and disarming with another. In this mode, the system will shorten the siren time to 2 seconds, the immobiliser arm time to 5 seconds, and the settling time to zero. To exit this mode, simply wait for 2 minutes without any further inputs.

Note that in Quick Test mode, any movement detected by the microwave sensor will trigger only the tell tale and not the siren. The 2 minute timer will not be extended.

### Location of Alarm Components

The alarm system components are located as follows:

- Electronic Controller/Immobiliser: Mounted on the top face of the scuttle beam at passenger's extreme end. Accessible after removal of the fascia dash panel.
- Siren Unit: Mounted on the underside of the front subframe LH longeron, ahead of the lower wishbone forward pivot. Accessible after removal of the front undertray.
- Microwave sensor: Mounted behind the centre console.
- Door Sensor: Switch incorporated into each door latch mechanism.
- Tailgate Sensor: Incorporated into the latch mechanism.

### MR.2 - CENTRAL DOOR LOCKING

The central door locking (CDL) operates on the driver's and passenger's doors in conjunction with the security alarm system.

#### To open the doors from outside:

To unlock the doors from outside, press the central, unlock button on the transmitter key. The first press will unlock just the driver's door. Press a second time to unlock the passenger's door.

When the door is opened, a fully closed window will drop slightly, preparatory to easing its subsequent closing, and the interior and footwell will be illuminated. If the driver's door is opened whilst the ignition is off but the key is in position, or if the exterior lights are switched on, an audible warning will sound.

On shutting the door, the window will close automatically unless already open by request, and the footwell illumination will be extinguished. The interior lamp will remain lit for 2 minutes, or until the ignition is switched on.

#### Interior Door Lock Switch

If it is desired to lock the doors from inside the car, for example to deter highjack attempts, press the door lock switch in the cluster inboard of the steering column, with ignition on or off. Both doors will be locked and the switch will light up as a reminder.

Alternatively, each door can be locked individually by depressing the button at the rear end of each door sill, but this action will not activate the lock switch illumination.

#### Dynamic (drive away) Locking

This selectable feature will automatically lock the doors when road speed first exceeds 10 mph (15 km/h). The doors will remain locked until either the interior door lock switch is pressed, or each door is unlocked manually by lifting the door sill button.

To select Dynamic Locking, turn on the ignition and hold the interior door locking switch pressed for at least 5 seconds, until a single beep is heard as confirmation. The feature will remain selected throughout further ignition cycles until the switch is again pressed for 5 seconds and a double beep is heard, confirming de-selection.



Note that the lighting up of the interior door locking switch provides a visual indication of the door lock status (locked when lit).

**WARNING: Whether locked using the locking switch, sill buttons or 'drive away locking' feature, the interior release handles will be disabled. Before opening, the door must first be unlocked by pressing the interior lock switch, or lifting the door sill button.**

### To open the doors from inside:

To open the door from inside, first unlock if necessary by pressing the interior lock switch, or lifting the door sill button, and then pulling the door release handle located towards the front of the door.

On opening the door, a fully closed window will drop slightly to aid subsequent door closing, and the interior and footwell lamps will light. If the driver's door is opened when the ignition is off but the key is in position, or if the exterior lamps are on, an audible warning will sound.

After shutting the door, the window will close automatically (unless already open by request), and the interior lamps will be extinguished after a 2 minute delay.

To lock both doors, press once the raised logo button on the transmitter key.

### Locking The Doors Mechanically

In the event of a discharged vehicle battery, or an inoperative transmitter key, the right hand door may be locked by pressing down the door sill button, and holding the exterior handle raised as the door is closed. The left hand door may be locked in a similar manner, or alternatively, may be locked by using the key in the exterior lock barrel; insert the key, turn fully clockwise, return to the vertical and withdraw. To unlock, insert the key in the lock, turn fully counterclockwise, return to the vertical and withdraw.

### Note:

- Locking the doors mechanically will not arm the alarm system.
- When locking both doors by pressing down the sill buttons, be aware of the potential for inadvertently locking the keys in the vehicle.

### Inertia Switch

The safety inertia switch is designed to operate on impact, typified by vehicle collision, to switch off the fuel pump, and thus minimise any fire hazard. The central door locking will also be triggered to unlock the doors.

The inertia switch is mounted on the backstay at the left hand side of the engine bay, ahead of the airbox, and is reset by pressing the rubber diaphragm button on the top of the unit.

### CDL Component Location

A CDL actuator is mounted on a plate integral with the latch mechanism with which it interacts via a rotary link. A CDL control module is mounted on the passenger end of the scuttle beam, at the top of the cabin side vertical face, and is accessible after removal of the fascia lower panel.

## MR.3 - ELECTRIC WINDOWS

The switches for the electric window operation are mounted in the door trim panel armrests, a single switch for the passenger and one for each door for the driver. The switches are operative with the ignition key at position I or II, at which time the icon in the switch will be illuminated.

To lower a window, press down the appropriate switch; if held for more than a second, the window will automatically lower fully. Lift the switch to raise the window (no one-touch raising).

To ease door closure, and optimise the sealing of the frameless door glass against the weatherstrips, a fully raised window will automatically drop a small distance when the door is opened (preparatory to closing), and rise again after the door is shut.

**Note:** If the battery supply is interrupted, the one touch down and auto drop features will not function. There will be an increased risk of damage to the door window seals until:

- each window is fully raised and the switch held for 2 seconds (a click will be heard).
- each window is fully lowered and the switch held for 2 seconds ( a click will be heard).



The electric window lift mechanism uses an electric motor and winder drum driving a steel cable around top and bottom guide pulleys to a lift block. The window glass is fixed to the lift block which is guided by a vertical rail. Fuses C9 and C10 protect the window lift motors, and C33 the control switches. The door harnesses are routed to the scuttle area via a grommet in the 'A' post area ahead of the door hinge post.

### MR.4 - DOOR MIRRORS

Rear view mirrors are fitted on both driver's and passenger's doors, and include the following features:

- Electric adjustment of mirror glass;
- Mirror glass heaters;
- Optional electric fold flat facility;

*Mirror adjustment:* The mirror control switch is located in the driver's door armrest, ahead of the door window switches, and comprises a combined rotary selector switch and joystick. To adjust the mirror, turn the ignition key to position I or II, select the right or left hand mirror by turning the knob to the appropriate arrow, then use the knob as a joystick to move the mirror plane in any of four directions. Note that the mirror glasses are convex to provide a wider field of vision, but by so doing, make objects seem smaller and farther away than when viewed through a flat glass. Take care when judging distances and approach speeds until familiarity has been gained.

*Fold flat (if fitted):* If necessary, to reduce obstruction when parked, both mirrors may be folded flat against the doors; turn the ignition key to position I or II, select the central 'fold' rotary position on the joystick, and hold the joystick rearwards until both mirrors have stopped moving. To unfold, hold the joystick forwards until mirror movement stops. The field of vision setting will be retained.

*Mirror heating:* Heating elements in the mirror glasses are energised in conjunction with that of the heated rear screen. The switch is located in the heater control panel, and will light up amber when the heater circuits are operating, but due to the high current demand, this function requires the engine to be running. The circuits will turn off after the switch is pressed a second time, or the ignition is switched off, or automatically after a ten minute period has elapsed.

### **Component Location**

A 'mini' relay for the heater circuit is mounted in the front fuse/relay station. Mirror control switch fuse is C33, HRS/mirror heater switch fuse C28, heater relay input fuse MC6, relay output to mirrors fuse C31.





Blank page



## MR.5 - SWITCHES & INSTRUMENTS - DRIVER'S INFORMATION

### Ignition Switch/Steering Lock

The switch/lock is located on the right hand side of the steering column. With the key out of the switch, the steering column is locked, and the following electrical circuits will function:

- Locking and alarm system.
- Horns.
- Hazard warning lamps.
- Sidelamps and headlamps.
- Fuel filler flap release.
- Interior lamps.
- Automatic operation of cooling fans and re-circ. pump.
- Glovebox latch.
- Boot auxiliary power socket.

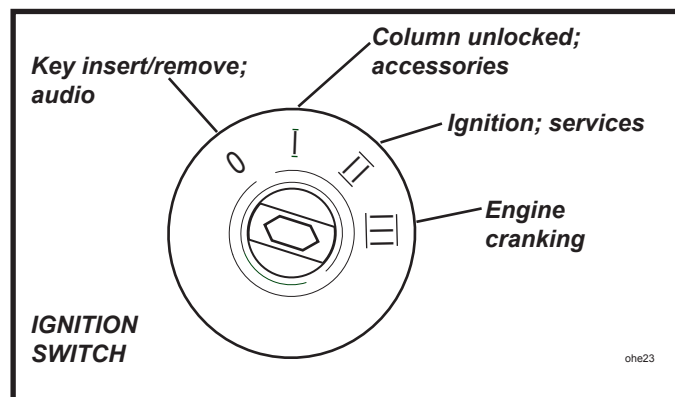

- 0** With the key inserted into the switch at position '0', the audio system and glovebox lamp are functional.
- I** To unlock the steering, turn the key clockwise to the 'I' position. If the key is reluctant to turn, wriggle the steering wheel to ease the load on the steering lock. At this 'accessories' position, the following electrical circuits will function in addition to those above:
  - Power windows.
  - Windscreen wiper and washer.
  - Interior fan.
  - Door mirror adjustment and fold.
  - Cabin auxiliary power socket.
- II** Turn further clockwise to the 'ignition' position to activate all remaining electrical systems (note that some circuits require the engine to be running).
- III** Turning further clockwise to 'III' against spring pressure will operate the starter motor. As soon as the engine starts, allow the key to return to position 'II'. For the correct starting procedure, see the later chapter 'Starting Procedure & Running In'. To stop the engine, turn the key back to 'I'.  
Note that in order not to compromise engine starting, all electrical functions operative at position 'I', will drop out whilst the engine is being cranked.
- 0** To remove the key, turn fully counterclockwise to '0' and withdraw. The steering column lock will be activated when the key is withdrawn but may not engage until the steering is turned and the mechanism is aligned.

**NOTICE:** DO NOT leave the ignition switched on for long periods without the engine running. Although the engine ignition system itself draws no current when the engine is stopped, a battery drain will occur through other circuits even when auxiliary equipment is not being used.

### WARNING:

- Do not push or tow the car unless the key is first used to unlock the column and is then left in the lock. Withdrawing the key will cause the steering to lock.
- Never remove the key from the ignition switch or turn off the ignition while the car is moving. Withdrawing the key will cause the steering to lock and may cause an accident resulting in serious injury or death.



## TELL TALE LAMPS

Tell tale lamps are incorporated into the instrument panel to provide important information about various vehicle systems.

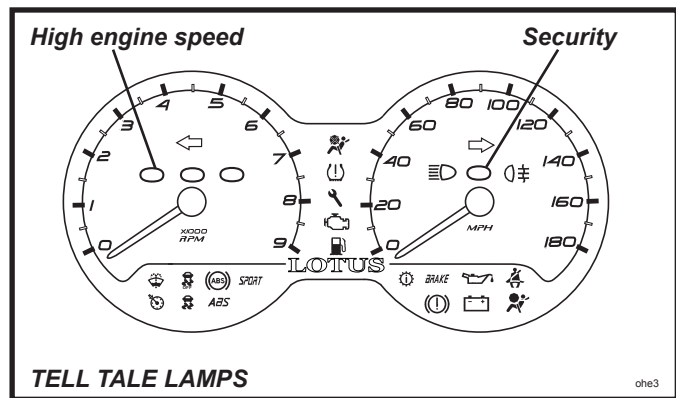

### Bulb Check

In order to check that the warning systems are functional, all operative tell tale lamps will light for a few seconds each time the ignition is switched on - refer to the text below for details of this feature relating to particular lamps. If the lamp does not light as specified, it is possible that the warning circuit or instrument assembly may be at fault; see your dealer without delay, and be aware that there may be no warning of a malfunction with that feature.

### Turn Tell Tale (green)

A left turn tell tale is incorporated into the upper face of the tachometer, and a right turn tell tale in the speedo face. A bulb check will light the lamps for about 3 seconds following ignition switch on.

When the left hand or right hand turn indicators are operating, the appropriate green tell tale will flash in unison together with an audible tone. If the tell tale fails to light, or flashes at an unusual or irregular rate, check the operation of the turn indicator lamps immediately.

### High RPM Tell Tales (red)

Three red tell tale rings are incorporated into the tachometer face to warn that maximum engine speed is being approached. No bulb test function applies.

Maximum engine speed is governed for both the continuous and transient (during acceleration) states, and are detailed in the later section 'Tachometer'.

As the rate of rpm increase is potentially greater in the lower gears, the tell tale trigger points are tailored to accommodate the reaction time available. As maximum rpm is approached, the tell tales will light in the following left to right sequence:

- one red light;
- two red lights;
- three rapidly flashing lights with an audible warning.

When exploiting maximum acceleration, gearchange upshifts should be made immediately the three flashing lights appear.

### NOTICE:

- A graduated engine speed limit is imposed on a cold engine to reduce possible damage and wear from a delinquent driving style.
- Using maximum rpm and the above tell tale facility should be restricted to occasions when maximum acceleration is required. Overuse will compromise powertrain service life.
- The engine is not protected from overspeeding caused by erroneous or premature downchanging. Such misuse could result in catastrophic failure, not covered by the vehicle warranty.

### High Beam Tell Tale (blue)

This lamp glows blue whenever the headlamp high beams are operating. A bulb check will light the lamp for about 3 seconds following ignition switch on.

### Security Alarm Tell Tale (red)

For details of the vehicle security alarm and its tell tale, see sub-section MR.1

**Rear Foglamp Tell Tale  (amber)**

This lamp glows amber whenever the rear fog lamp is operating (see 'Rear Fog Lamp Switch'). A bulb check will light the lamp for about 3 seconds following ignition switch on.

**Passenger Airbag Off Switch  (amber)**

This amber tell tale will light with ignition on, whenever the passenger airbag has been disabled by the key operated switch at the passenger end of the fascia. A bulb check will light the lamp for about 3 seconds following ignition switch on.

**Tyre Pressure Monitoring System (TPMS)  (amber)**

If the car is so equipped, with ignition on, this amber tell tale, together with an audible alert, warns of low pressure in one or more tyres. Stop the car as soon as it is safe so to do, and take appropriate action. A bulb check will light the lamp for about 3 seconds following ignition switch on.

**Scheduled Service Tell Tale  (amber)**

The Engine Control Module (ECM) on the Evora is also used to manage various related electrical systems, and is able to detect certain types of fault, which may or may not be apparent to the driver. If such a fault is detected, which has no detrimental effect on exhaust emissions (see MIL below), this amber tell tale will light for the first 30 seconds after turning on the ignition. Interrogate using the Lotus TechCentre.

A bulb check will light the lamp for about 3 seconds following ignition switch on.

**Engine Malfunction Indicator Lamp  (amber)**

The engine Malfunction Indicator Lamp (MIL) is provided to warn the driver that the engine management system has detected a fault which may result in increased noxious emissions from the exhaust. In order to minimise emissions and potential engine damage, various operational limitations may automatically be applied. A circuit check will light the lamp for about 3 seconds following ignition switch on.

- i) If the MIL lights continuously whilst driving, immediately reduce speed and adopt a moderate driving style. Seek dealer advice without delay and avoid all unnecessary journeys.
- ii) If the MIL flashes, an engine misfire has been detected which is likely to cause overheating damage to the catalytic converters. Slow down immediately and be prepared to stop.
  - If the MIL then stops flashing, and is lit continuously, proceed with caution and seek dealer advice.
  - If the MIL continues to flash, stop the car as soon as it is safe so to do, and switch off the engine. Seek dealer advice.

**NOTICE:** Continuing to drive the car with a flashing MIL may cause overheating damage to the catalytic converters, possible engine damage, increased emissions, and impaired fuel economy and driveability.

In order to comply with emissions regulations, data regarding activation of the MIL is recorded in the engine electronic controller, and may be downloaded by Lotus dealers using the TechCentre.

**Low Fuel Level Tell Tale  (amber)**

A circuit check will light the lamp for about 3 seconds following ignition switch on. Thereafter, this amber tell tale will light, with ignition on, when approximately 5 litres of fuel remain. Refuel at the next opportunity.

**Low Washer Fluid Level Tell Tale  (amber)**

This amber tell tale is provided to warn of low fluid level in the reservoir serving the windscreen and headlamp powerwash jets. A bulb check will light the lamp for about 3 seconds following ignition switch on, but if the lamp then remains lit, or lights after washer use, refill the reservoir with a suitable fluid at the first opportunity.

**Cruise Control Tell Tale  (amber)**

If the car is so equipped, this amber tell tale indicates when the cruise control is enabled. For full details of this system, see later. A bulb check will light the lamp for about 3 seconds following ignition switch on.

**Traction Control Off Tell Tale  (amber)**

This amber tell tale reminds the driver that the traction control has been manually switched off. Lotus



Traction Control should always be active when driving on public roads in normal conditions. To re-activate LTC, press momentarily the LTC off switch and check that the tell tale is extinguished. For LTC details, see later.

A bulb check will light the lamp for about 3 seconds following ignition switch on.

### **Traction Control Tell Tale (amber)**

This amber tell tale will flicker whenever the Traction Control system is triggered to indicate to the driver that the tractive limit is being breached.

A bulb check will light the lamp for about 3 seconds following ignition switch on, but if the tell tale lights constantly, a fault has been detected, and traction control will not be enabled.

### **ABS Tell Tale *ABS* (amber)**

A bulb check will light the lamp for about 3 seconds following ignition switch on, but if the lamp then remains lit, or comes on whilst driving, a fault in the anti-lock brake system is indicated. The base brake system will continue to operate normally, but without the anti-lock feature. Heavy braking, or braking on slippery surfaces may cause one or more wheels to lock and result in reduced steering response and possible loss of control.

The car may continue to be driven with appropriate care and anticipation, but should be checked and repaired at the earliest opportunity.

### **Sport Tell Tale *SPORT* (amber)**

This tell tale will light up amber to indicate that 'Sport' mode has been selected, delivering increased throttle response and a reduced level of traction control. This selection will default off when the ignition is next turned on. A bulb check will light the lamp for about 3 seconds following ignition switch on.

### **Brake Tell Tale (red)**

A circuit check will light this lamp for about 3 seconds following ignition switch on. The tell tale will then remain lit if the parking brake is applied. Check that the tell tale is extinguished when the parking brake is released, as driving the car with the brake not fully disengaged will cause overheat damage to the rear brakes.

With the parking brake released, if the tell tale should light at any time after the 3 second check period, stop the car immediately, as the circuit has detected a dangerously low level of brake fluid in the master cylinder reservoir, possibly caused by a hydraulic leak in one of the separate front or rear brake circuits. In the event of a leak there is a danger that air may enter the hydraulic system and cause spongy operation and extended pedal travel. The divided brake circuit should ensure that emergency braking remains, but the car should not be driven until the fault has been identified and rectified.

Note that in order to inhibit false warnings of low fluid level due to surge effects, this circuit incorporates a 10 second delay, requiring that the signal be present for a minimum of this period.

### **Oil Pressure Tell Tale (red)**

This red tell tale warns of low engine oil pressure. The lamp will be lit whenever the ignition is on and the engine is stopped, but should go out as soon as the engine is started. If the lamp fails to go out after engine start up, or comes on when the engine is running, stop the engine immediately and do not restart until the cause has been investigated and rectified.

**WARNING: Continuing to run the engine with the oil tell tale lit could cause major engine damage or seizure, resulting in loss of car control and a crash. You or others could be killed or seriously injured.**

### **Battery Charging Tell Tale (red)**

This red tell tale will light whenever the ignition is on and the engine is stopped. If it lights any time when the engine is running, it indicates that the battery is not being charged, which may be due to a broken auxiliary drive belt, or an electrical fault.

Stop the car as soon as safely possible and turn off the engine. The auxiliary belt also drives the engine water pump, without which function the engine will overheat very quickly. If it can be determined that the auxiliary belt and water pump are functioning correctly, it may be possible in favourable daylight conditions, to drive a short distance to a repair facility, but do not, under any circumstances, allow the battery to become completely discharged by continuing to drive, as this may result in engine damage and the car being stranded in a dangerous position.

**Seat Belt Tell Tale  (red)**

As a reminder to fasten the seat belts, the seat belt tell tale in the instrument cluster will flash red for about six seconds following ignition switch on, accompanied, if the driver's belt is not fastened, by an intermittent audible tone. Thereafter, if the driver's belt remains unfastened, the lamp will light continuously, but if vehicle speed should exceed 15 mph (20 km/h) the lamp will flash, accompanied by a beeping tone for a period of two minutes, unless curtailed by a speed reduction below 10 mph (15 km/h) before this time.

**Airbag Tell Tale  (red)**

The airbag safety system, including the pre-tensioning seat belts, has a self-diagnostic feature which lights the red tell tale if a fault is detected. As a bulb check, the tell tale will light for about six seconds following ignition switch on, and then go out, but if the lamp remains lit, or comes on at any other time, a fault in the airbag system is indicated, which should be rectified without delay by your Lotus dealer.

**INSTRUMENTS****Speedometer**

This analogue display uses an illuminated pointer to indicate road speed in either mph or km/h dependent on market. Each time the ignition is switched on, a re-setting routine will be performed with the pointer sweeping to full scale and back to zero. The scale backlighting and pointer will be illuminated whenever the ignition or sidelamps circuits are active.

Note that a digital speed display in alternative units (mph or km/h) is available in the information panel menu (see later).

**Tachometer**

This analogue display uses an illuminated pointer to indicate engine speed in revolutions per minute. The engine management system graduates the maximum engine speed allowed during the warming up phase, and once normal running temperature has been reached, limits continuous engine speed to 6,600 rpm (or 7,000 rpm in Sport mode). During maximum acceleration through the lower gears, very short bursts up to 6,800 rpm are allowed (or 7,200 rpm in Sport mode).

Each time the ignition is switched on, a re-setting routine will be performed with the pointer sweeping to full scale and back to zero. The scale backlighting and pointer will be illuminated whenever the ignition or sidelamps circuits are active.

Three red tell tale rings are incorporated into the tachometer face to warn that maximum engine speed is being approached, but as the rate of rpm increase is potentially greater in the lower gears, the tell tale trigger points are tailored to accommodate the reaction time available. The tell tales will light in the following left to right sequence:

- one red light;
- two red lights;
- three rapidly flashing lights with an audible warning.

When exploiting maximum acceleration, gear upshifts should be made immediately the three flashing lights appear.

**NOTICE:**

- The use of wide throttle openings and/or high rpm before normal running temperature has been reached should be avoided. A graduated engine speed limit is imposed on a cold engine to reduce possible damage and wear from a delinquent driving style.
- Do not run the engine continuously at its maximum speed.
- The engine is not protected from overspeeding caused by erroneous or premature downchanging, the consequences of which could be catastrophic failure not covered by the vehicle warranty.
- Use of maximum rpm and the above tell tale facility should be restricted to occasions when maximum acceleration is required. Overuse will compromise powertrain service life.

**Odometer**

A vehicle total distance travelled indicator, in miles or kilometers, dependent on market, is displayed at the centre top of the instrument panel whenever the ignition key is inserted. See later for the trip distance function.



## Fuel Level Display

An indication of the level of fuel in the tank is displayed, with ignition on, in the form of a vertical bar graph in the instrument panel left hand screen. The solid bar within the outline, represents the proportion of fuel remaining in the tank.

When only 5 litres remains, an amber tell tale in the instrument panel will light. Refuel at the next opportunity.

The total usable fuel capacity is 60 litres (13 imp.gal), but for re-fuelling purposes, from the time the low fuel tell tale is triggered, approximately 50 litres can be accommodated. Note that from the point of low fuel tell tale activation to the gauge reading empty, is around 5 litres. The remaining balance of 5 litres should be treated only as an emergency contingent, the use of which may entail intermittent fuel starvation and potential engine damage. In such a situation, driving style should be modified to minimise engine load and cornering forces.

If maximum engine or handling performance is to be exploited, or severe gradients tackled, a high fuel level should be maintained to ensure the greatest safety margin of fuel supply.

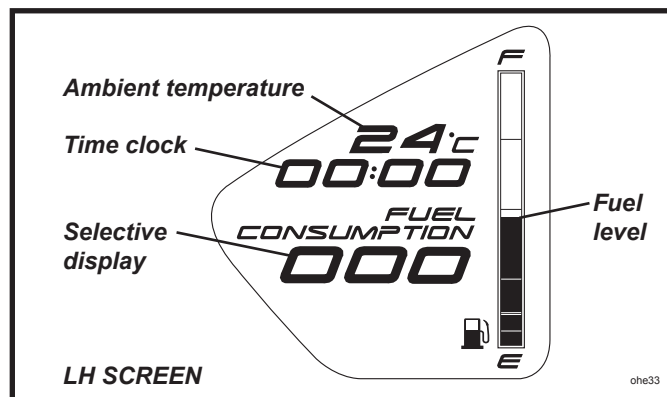

**NOTICE:** Do not allow the tank to run completely dry, as this could damage the catalytic converters and fuel pump. Any such consequence would not be covered by the vehicle warranty.

## Ambient Air Temperature Display

The outside air temperature is shown on the instrument panel left hand screen whenever the ignition is switched on, with units displayed in degrees Centigrade or Fahrenheit dependent on market. The sensor is mounted by a grommet into the RH side of the engine radiator air intake duct.

If the temperature drops to 4°C (39°F) or below, the display will flash for ten seconds, accompanied by a single audible chime to alert the driver to potentially hazardous road conditions. Note that optimum accuracy will be obtained when the car is moving.

To change the displayed units between Centigrade and Fahrenheit, see 'Information Switch' below.

## Time Clock

A digital 24-hour time clock is displayed in the instrument panel left hand screen whenever the ignition key is inserted.

To adjust the clock, see 'Information Switch' below:

## Information Switch

A button is mounted on the end of the left hand column stalk, and has different functionality with ignition on and off. With the ignition key inserted, but ignition **OFF**, the button operates as follows:

### Time clock adjustment

- Press the info. button for more than one second, until the hour display flashes.
- Press momentarily the info. button to advance the figure by one hour and repeat as necessary. Alternatively, a rapid double press will automatically scroll the display; press again to stop the scrolling at the desired figure.
- Press the info. button for more than one second until the seconds display flashes. Repeat the above adjustment procedure.
- Press the info. button for more than one second to enter the next mode:



### Ambient temperature units

- Current temperature display units will now be displayed. To change from °C to °F, or vice-versa, press momentarily the info. button.
- To retain the displayed units, press the info. button for more than one second to enter the next mode:

### Tyre pressure units (if TPMS is fitted)

- Current tyre pressure units will now be displayed. To change from bar to psi, or vice-versa, press momentarily the info. button.
- To retain the displayed units, press the info. button for more than one second to exit the adjustment mode.

With the ignition **ON**, the info. button operates the trip functions as follows:

### Trip Recorder

The instrument panel left hand screen allows a menu of trip functions to be displayed, selected by the 'info' switch on the end of the steering column left hand stalk. When the ignition is turned **ON**, the panel will display the trip distance since the last reset, in either miles or kilometres, dependent on market.

A single momentary press of the info. button will scroll to the next function in the following sequence:

- Trip distance.
- Range; Driving distance available on current fuel level, based on average fuel consumption since reset.
- Average fuel consumption; In mpg or km/l dependent on market. This display will be blank for the first 5 minutes of driving time since reset, to allow data to stabilise.
- Road speed; Displayed digitally in alternative units (mph or km/h) to those of the analogue instrument.
- Trip distance.

The Trip Distance, Range, and Average Fuel Consumption can all be reset, by selecting that function and then pressing the info. switch for more than one second until the display zeroes.

### Coolant Temperature Display

An indication of the engine coolant temperature is displayed, with ignition on, in the form of a vertical bar graph in the instrument panel right hand screen. To optimise display space, the shown scale commences at 60°C (140°F), and finishes at 120°C (250°F).

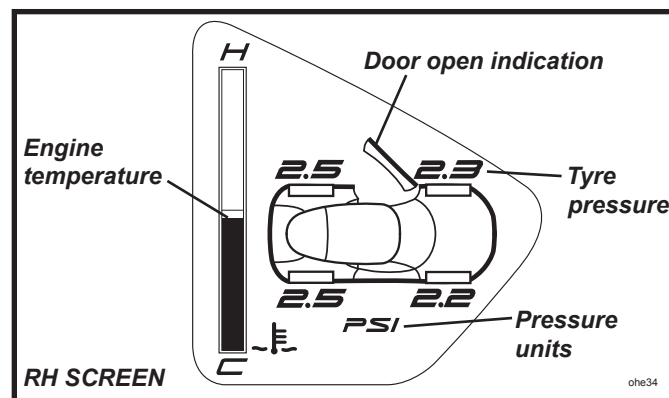

The running temperature will fluctuate a certain amount as the operating conditions change, and during periods of idling or in heavy traffic, the temperature may rise to over 100°C (212°F), with the cooling fans switching on at half speed at approximately 98°C (208°F), and full speed at approximately 103°C (217°F). In order to prompt closer monitoring by the driver of temperatures over 110°C (230°F), the temperature icon will flash and be accompanied by the message '**Engine too hot**' displayed above the car silhouette.

The pressurised cooling system has a boiling point of over 120°C (250°F), and if the temperature approaches this level, the car should be stopped and the engine allowed to idle for a few minutes whilst the temperature is monitored. If the temperature continues to rise, there is a danger of engine damage; switch off and seek qualified assistance.

**NOTICE:** After a heavy snowfall, ensure that the radiator cooling outlet grille in the front body is cleared of snow before driving the car, or overheating may result.





## Tyre Pressure Monitoring System (TPMS)

On cars so equipped, a sensor incorporated into each of the tyre valves, monitors the air pressure inside the tyre, and supplies an onboard control module with this data by radio transmission. As soon as the car has been driven a short distance, tyre pressure readings will be displayed against the corresponding wheels on the vehicle silhouette in the instrument cluster right hand screen. If any pressure should fall below 75% of the recommended value, an alert message is sent to the instrument panel, causing the tyre pressure tell tale  to light up amber, and the corresponding pressure on the silhouette to flash.

If this warning should occur, stop the car as soon as it is safe so to do, and examine the affected tyre. If there is no visible damage and a tyre pump is available, correct the pressure to that stated in the Technical Data section of this handbook, and proceed with caution to a tyre dealer for professional inspection and advice. Note that the tell tale will automatically be extinguished when the correct pressure is restored. If the tyre is punctured, or no inflation equipment is available, consider using the emergency tyre inflator aerosol (see page 128), but observe the associated **WARNINGS** and be aware that the TPMS sensor in the tyre will be disabled by the sealing fluid, and must subsequently be renewed.

The TPMS incorporates self-malfunction recognition, and if a fault is detected, the low tyre pressure tell tale will flash for one minute and then remain constantly lit, this sequence being repeated for subsequent ignition cycles; **the system may not be able to detect or signal low tyre pressure**. See your dealer without delay.

Be sure to advise any tyre fitters or service technicians that TPMS is fitted, and that any replacement tyre valves include the correct pressure sensors. If a fault is indicated after wheel or tyre replacement, it is likely that a sensor has been incorrectly fitted or damaged. If a tyre valve is renewed, or is moved to a different wheel position, the TPMS will automatically identify the new configuration.

Note that the pressure sensors are powered by integral batteries, with an average service life of 10 years. It is recommended to renew all pressure sensors at this time interval.

## Door/Tailgate Open Display

The instrument cluster right hand screen includes a plan view silhouette of the car, which will graphically show when either door is open, or indicate an open tailgate by flashing the corresponding area. This situation will endure until the panel is fully latched.

## Lighting Switches

Lighting functions are controlled by a vertical row of three push button switches mounted in the fascia outboard of the steering column. Each switch is pressed once to switch on, and pressed a second time to switch off. Each switch button incorporates a function symbol which is backlit red with the sidelamps and ignition switched on, and which lights up brightly when the circuit is active.

## Sidelamp Switch

The topmost outboard switch functions with or without the ignition, and switches on the sidelamps and some switch illumination. To help locate the switch in the dark, when the ignition is on, the button symbol will be backlit red, changing to brightly lit green when the circuit is activated.

Note that the headlamps must be off before the sidelamps can be switched off.

## Headlamp Switch

The second switch down functions with or without ignition, and switches on the headlamps together with the sidelamps and some switch illumination. The switch button symbol is backlit red with the sidelamps on, and lights up green to indicate when the circuit is active. The steering column lever switch (see later) is used to select main or dip beam.

A second momentary press will switch off the headlamps, but leave on the sidelamps. To switch off both the side and headlamps, hold the switch pressed for more than one second.

## Homesafe

The Homesafe feature keeps the headlamps lit for a 30 second period after locking/arming the alarm, in order to light the departure route. To activate Homesafe;

- leave the headlamps switched on;
- withdraw the ignition key;
- use the transmitter to lock/arm the alarm.

The master lighting switch will flash during the 30 second period to indicate that Homesafe is operating.



## 'Lights On' Warning

If the lights are on when the ignition is switched off, a 'lights on' audible warning will sound when the driver's door is opened.

## Rear Fog Lamp Switch (where fitted)

The lowermost outboard switch controls the single rear fog lamp, which will operate only when both the ignition and the headlamps are active. The switch button symbol is backlit red with the sidelamps on, and lights up amber to indicate when the circuit is active

Note that the switch will default to 'off' whenever the headlamps or ignition are switched off, such that the switch must again be pressed when fog lamp operation is required.

In some territories, rear fog lamps may be used legally only in conditions of 'seriously reduced visibility'. Be aware that indiscriminate or forgetful use of the rear fog lamp can cause distraction and discomfort to following traffic.

## Reversing Lamp, Parking Aids and Reversing Camera

With the ignition switched on, selection of reverse gear will cause:

- The reversing lamp to light.
- If fitted, the parking aid system will sound an audible acknowledgement, and then search for objects at bumper height within the detection zone of about 1.5 m (5 ft) around the rear of the car. When within this range, an intermittent beeping will be heard, which increases in frequency as the distance is reduced, becoming a continuous tone at around 300 mm (1 ft). Be aware that the sensitivity of the system will vary according to the size, position and material/density of an object.
- If fitted, the reversing camera will switch on and display an image on the audio set screen, if and when the set is manually switched on. Note that in order to cover the whole width of the car, the view will be distorted from a conventional image.

Take time to familiarise yourself with the image displayed, the parking aid beeping frequency, and the actual distance being detected before fully utilising these systems.

## Hazard Warning Lamps Switch

The hazard warning switch button is located inboard of the audio set, and is backlit red when the sidelamps are switched on. The switch is enabled at all times, and when pressed, causes simultaneous flashing of all the exterior turn lamps. In addition, the switch button graphic will flash, and an accompanying audible tone will sound. Press the button a second time to switch off.

## Instrument and Switch Illumination

The fascia mounted push button switches are backlit red whenever the sidelamps and ignition are switched on. The sidelamps switch itself is backlit with the ignition on. Most switches will light up brightly when that circuit is activated. The brightness of both the backlighting and active states is dimmed with the sidelights on, in order to prevent distraction in the dark. Similarly, the red displays in the instrument panel side screens are dimmed when the vehicle lights are on.

The speedometer and tachometer illumination is provided by white LEDs, with the pointers coloured red. The lighting level of these instruments and that of the heating/ventilation control panel, may be adjusted by a switch button inboard of the steering column:

- To set the nighttime level, switch on the sidelamps and press and hold the panel illumination button; the brightness will progressively increase. Release the button at the required level.
- The next press of the button will progressively decrease the brightness. Release at the required level.
- To set the daytime level, repeat the above procedure with the sidelamps switched off.



## Steering Column Lever Switches

Lever switches are provided on the steering column, one on the left for headlamp functions, and one on the right for windscreen wiping and washing.

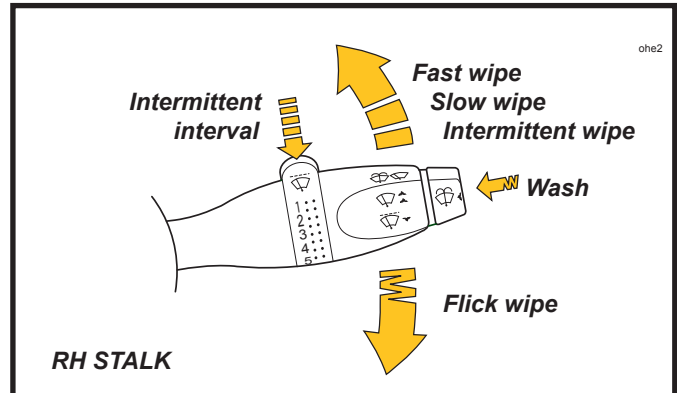
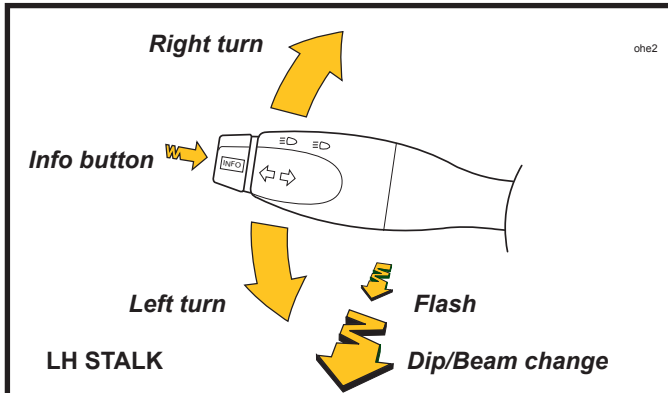

## Turn Indicators/Headlamp Flash/Dipswitch

**Turn Indicators:** The turn indicators operate only with the ignition switched on. Move the lever down to indicate a left hand turn, and up for a right turn. The switch will be cancelled when the steering wheel is returned to the straight ahead position.

For convenience, when signalling a lane change, lightly pressing the switch up or down will allow its return under spring action. Pressing the switch for less than a second will trigger three flashes of the indicators.

**Headlamps:** The left hand lever switch is operated by pulling the left hand lever switch towards the steering wheel, to one of two spring loaded positions, and then releasing.

**Headlamp Flash:** To flash the headlamp main beams with or without ignition, pull the lever switch to the first position; the beams will light until the lever is released.

**Dip/Main Beam Switching:** When the headlamp switch is pressed (see page 64), the headlamps will switch on in either dip or main beam mode according to the last made selection. To change from one to the other, pull the lever fully towards the steering wheel to the second spring loaded position, and then release. Each such action will cause alternate selection of main and dip beams. Note that with ignition on, the main beam tell tale in the instrument panel will indicate the current status.

**Info Button:** Momentarily pressing the 'Info' button on the end of the stalk will scroll through a menu of trip functions (see above).

## Windscreen Wiper & Washer Control

The right hand lever switch is enabled at ignition key positions I and II, and is operated as follows:

### Wiper functions

- To 'flick' wipe the screen, press the lever switch downwards against spring pressure and release. The wiper will sweep the screen once at slow speed. Holding the lever downwards will activate further slow sweeps until released.
- For intermittent wipe, push the lever up to the first position, and select the wipe interval by rotating the numbered collar to one of its six positions, the wipe frequency increasing at higher numbers.
- For slow speed continuous wipe, move the lever upwards to the second position.
- For fast speed continuous wipe, push fully upwards to the third position.

**Note:** In very cold weather, before attempting to use the wiper, ensure that the blade is not frozen to the screen (use windscreen de-icer fluid), or damage to the blade or circuit fuse may be caused.

### Windscreen washer functions

- For short wash/wipe, a momentary press of the button on the end of the stalk will trigger the washer pump and a single sweep of the wiper.
- For a longer wash/wipe, press the end button for longer than one second to operate the washer, and to trigger 3 sweeps of the wiper.



## Headlamp Powerwash

With ignition and headlamps on, the headlamp powerwash will be activated for a short burst at the first, and every subsequent fifth request of the screen wash switch. Cycling of either the ignition or headlamp switch will reset this timing.

The powerwash jets are contained in a sliding module which normally sits flush with the surface of the headlamp cover. When activated, a stepper motor with combined pump, operates to lift the module proud of the headlamp to expose the jets and deploy a pair of high pressure water streams to the lamp cover. The module then retracts. Note that this function shares the water reservoir used for the windscreen washers.

### Note:

- The combined washer reservoir has a low fluid level sensor which will activate a tell tale in the instrument cluster.
- The windscreen washer jets have heating elements which are active whenever the ignition is on.

## Horn

To sound the twin tone horns, which are operative at all times, press the centre pad on the steering wheel.

## Passenger Airbag Defeat (PAB) Switch

If a rearward facing child seat is to be used in the front passenger seat of the Evora, it is essential to switch off the passenger airbag. If an accident should occur and trigger airbag inflation, the back of the seat could be subjected to a force sufficient to seriously injure or kill the child.

A PAB switch is located at the end of the passenger fascia, accessible only with the door open, and is operated using the mechanical ignition key; insert the key and turn clockwise to the 'OFF' position, and withdraw the key. With the ignition switched on, a tell tale lamp in the instrument panel will light up amber as a reminder that the passenger airbag has been disabled. To reinstate airbag operation, insert the key in the PAB switch and turn counterclockwise.

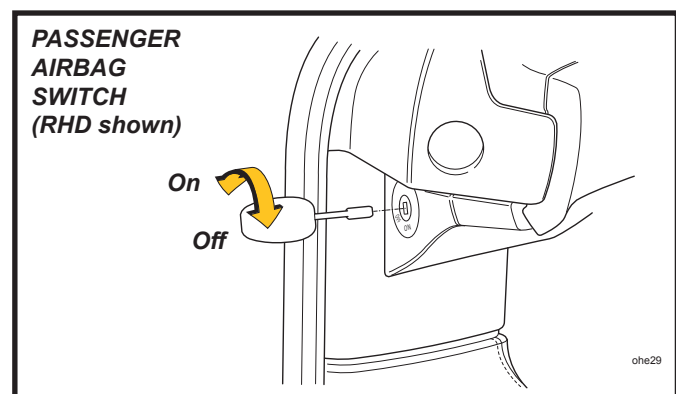

## Interior Lighting

The main interior lamp is located centrally in the roof and incorporates a three position rocker switch:

- *Forward end depressed;* Lamp is switched off ('0').
  - *Rear end depressed;* Lamp is switched on with or without ignition ('1').
- NOTICE:** To guard against flattening the battery, ensure that the lamp is not switched on when leaving the car.
- *Switch central;* This is the normal, courtesy position (door symbol).

A 'mood lighting' strip crossing the fascia and extending along both door trim panels, is controlled in conjunction with the main interior lamp. Each front footwell also houses a separate lamp to aid ingress.

With the interior lamp switch set to the courtesy position; when the transmitter key button is pressed to unlock the doors, the interior lamp and mood lamps will fade on for a maximum period of 2 minutes. If a door is opened, the footwell lamp will also light. On closing the door, the footwell lamp will be extinguished, but the interior and mood lighting will abide for 2 minutes or until the ignition is switched on.

Similar logic will apply when opening the door to exit the vehicle, with the lighting being extinguished when the doors are locked using the transmitter, or after a period of 2 minutes.



## Inertia Switch

The safety inertia switch is designed to operate on impact, typified by vehicle collision, to switch off the fuel pump, and thus minimise any fire hazard. The central door locking will also be triggered to unlock the doors.

The inertia switch is mounted on the backstay at the left hand side of the engine bay, ahead of the airbox, and is reset by pressing the rubber diaphragm button on the top of the unit.

## Lotus Traction Control

Lotus Traction Control (LTC) is a software programme integrated within the engine management and ABS electronic control units (ECUs) and uses inputs from the wheel speed sensors to determine if wheelspin is occurring. If an excessive degree of wheelspin is detected, LTC will modulate fuel injector delivery, throttle opening and rear brake application, in order to control engine power output and spinning wheel inertia, until grip is restored. This feature can improve vehicle stability in some extreme conditions of use, especially where variable or differential side/side surface grip prevails, or when maximum vehicle performance is being exploited. Refer also to 'EDL' (see below).

If the traction control tell tale in the instrument panel is seen to flicker, this is an indication that the LTC has been triggered and electronic intervention is taking place; the tractive limit has been reached and driving style should be modified accordingly.

**WARNING: The enhanced vehicle control that this feature provides should not induce any relaxation of caution or vigilance by the driver. Physical limits of cornering and braking still apply, and excessive speed may result in loss of control and an accident. The driver is at all times responsible for the judgement of appropriate speed.**

*Traction Control 'Off' Button:* In certain unusual circumstances, such as loose surfaces, deep snow or when 'rocking' the vehicle free from mud, it may be desirable temporarily to switch off the LTC. An LTC 'off' button is provided in the fascia, outboard of the steering column, and is operative only with the ignition on.

To switch off LTC, hold the button pressed for one second, until the button surround lights up in conjunction with the amber 'LTC off' tell tale in the instrument panel.

### WARNING:

- **Lotus Traction Control should always be active when driving on the public highway in normal conditions.**
- **If the system is switched off when driving off-highway, be aware of the consequent change in vehicle behaviour and modify driving style accordingly.**

To re-activate LTC, briefly press the button a second time and check that the tell tale goes out. Irrespective of the system status when the ignition is turned off, LTC will automatically be activated next time the ignition is switched on.

If the on-board diagnostic system detects a fault with the LTC, the tell tale will be lit continuously; see your dealer without delay.

## Sport Mode (if fitted)

In order to cater for the preferences of some sport oriented drivers, a Sport Mode selector button is provided to deliver quicker throttle response, increased wheel slippage thresholds, no throttle reduction on detection of understeer, and a maximum continuous engine speed raised from 6,600 to 7,000 rpm. Note that switching off the Lotus Traction Control (see above) in conjunction with selection of Sport Mode, will retain the Sport features, but without any power induced wheelslip intervention. In all cases, anti-lock braking will be retained.

**WARNING: Be aware that selecting Sport Mode and/or LTC OFF, will alter the handling characteristics of the car. Drivers should exercise caution until familiarity has been gained in a controlled safe environment.**

The Sport Mode switch is located in the fascia panel outboard of the steering column. To switch on Sport Mode, turn on the ignition, and hold the button pressed for one second until the button surround lights up amber, accompanied by the amber 'SPORT' tell tale in the instrument panel. In order to prevent unintentional acceleration if the button is pressed whilst driving, in these circumstances, the button surround will flash in acknowledgement, but Sport Mode will not be activated until the throttle pedal has been fully released.



Briefly pressing the button a second time will switch off Sport Mode as soon as the throttle pedal is fully released.

Note that Sport Mode will default to 'off' at the next ignition cycle.

## Cruise Control

The cruise control system is operated by four switches mounted on the steering wheel spokes.

- On/off/cancel (lower left).
- Resume (upper left).
- Set/raise speed setting (upper right).
- Reduce speed setting (lower right).

The three operational states of cruise control are:

- Off.
- Enabled (but inactive).
- Active.

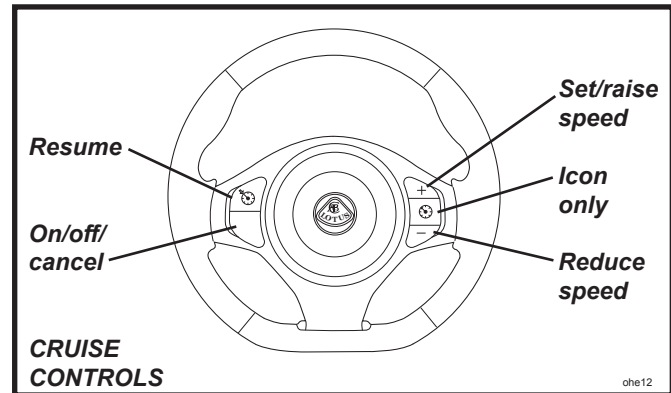

*To enable cruise control:* The system will always default to 'off' whenever the ignition is turned off. To enable cruise control, turn on the ignition, and press the on/off switch; the tell tale in the instrument panel will light to confirm that the system is enabled (although no speed has yet been set). Alternatively, this operation may be combined with that for activation, by pressing the on button followed by the set button (see below).

*To activate cruise control:* Drive the car to the desired cruising speed and press the set button. The accelerator may now be released, but the set speed will be maintained (road gradient and winds permitting). The accelerator may be used to increase speed temporarily without affecting the setting.

**Note;** The system cannot be activated below 20 mph (32 km/h) or above 125 mph (200 km/h).

*Deactivation:* Cruise control will be deactivated when any of the following actions occur:

- The brake pedal is depressed;
- The clutch pedal is depressed.
- The on/off/cancel button is pressed.

In any of these cases, normal manual speed control will be restored, but the system will remain enabled.

*Resume:* To resume cruise, press the resume switch. The vehicle speed will automatically adjust to the cruise setting.

*Changing the cruise setting:* Whilst cruise is active, the speed setting can be adjusted by holding down the '+' or '-' buttons to accelerate or slow the car to the desired new speed. On release of the button, that speed will then be set. Alternatively, a single short press of either button will increase or decrease the setting by 1 mph (1.5 km/h).

If the system is not active, the car can be driven to the desired speed, and the set button pressed.

*To disable cruise control:* To switch off the system, with cruise inactive, press the on/off switch; the tell tale lamp will be extinguished.



**MR.6 - COMPONENT LOCATION & FUSE RATINGS**

**Main Fusebox**

The main fuse and relay boxes are located at the front of the passenger footwell, protected by a removable panel secured by a quarter turn fastener at each top corner, and a location channel on the floor. Forty slots are provided for mini fuses which are numbered, and coloured according to their amperage rating, and may be pulled out from their slots using the fuse extractor tool clipped to the fusebox. Six maxi fuses protecting major circuits are also provided, along with six single contact change over micro relays and two 50A power relays.

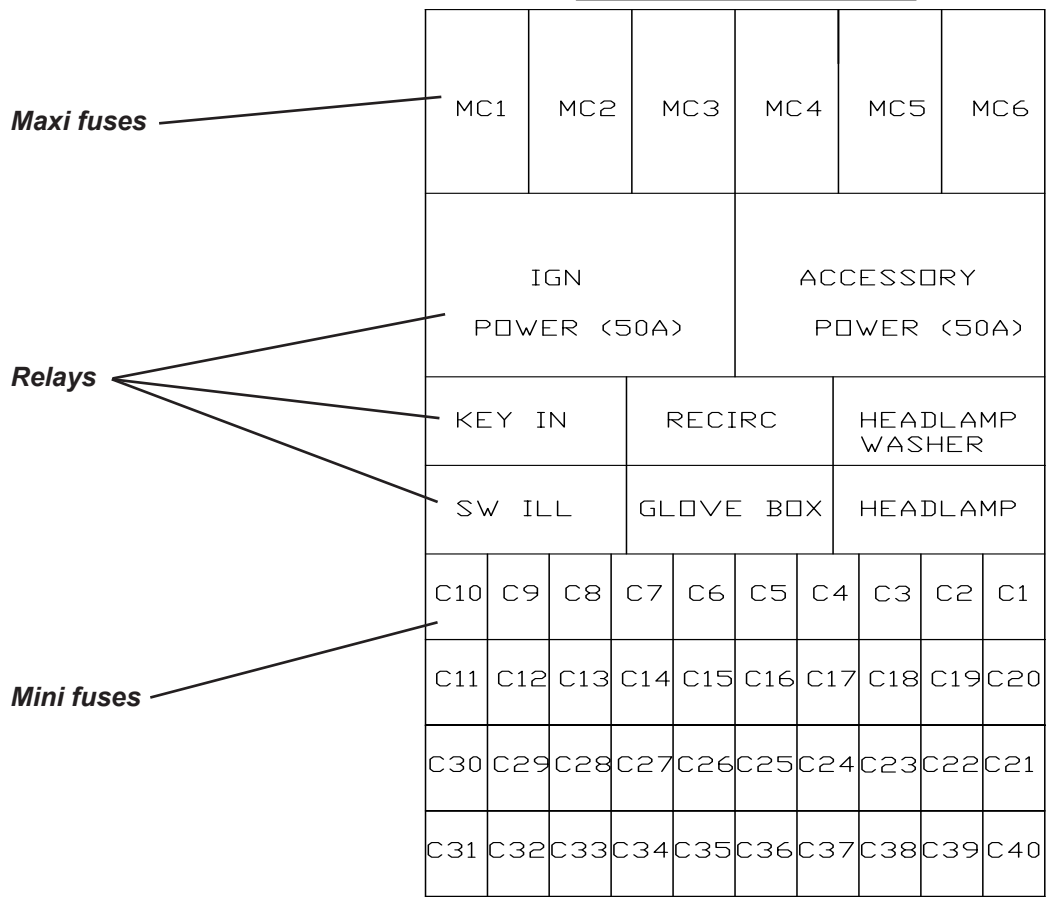

Slot	Rate	Circuit
C1	10A	Horn
C2	5A	Battery services
C3	5A	Alarm B+
C4	20A	Rad fan relay 1
C5	20A	Rad fan relay 3
C6	10A	Radio B+
C7	5A	Key-in relay
C8	2A	Ignition switch
C9	15A	Driver's window
C10	15A	Pass. window
C11	7.5A	Hazard & Turn
C12	3A	Interior lighting
C13	20A	Int. control mod.
C14	-	
C15	5A	LH sidelamps
C16	5A	RH sidelamps
C17	15A	LH headlamp
C18	15A	RH headlamp
C19	15A	Main beam
C20	3A	Rear foglamp

Slot	Rate	Circuit
C21	3A	Ign. services
C22	5A	ABS
C23	3A	Homelink
C24	3A	Brake lamps
C25	15A	HL powerwash
C26	5A	Alarm ignition
C27	-	
C28	5A	HVAC ignition
C29	5A	Washer jets
C30	5A	SRS unit
C31	3A	Heated mirrors
C32	5A	Washer pump
C33	5A	Mirror/window sw.
C34	20A	Wiper motor
C35	-	
C36	20A	Interior fan
C37	10A	Cabin pwr. socket
C38	-	
C39	-	
C40	-	

Slot	Rate	Circuit
MC1	40A	Battery positive
MC2	40A	B+, ignition
MC3	40A	Accessories
MC4	40A	ABS B+
MC5	25A	ABS B+
MC6	25A	HRS



**Front Relay Blocks**

Mounted on the front fusebox panel, is a block of relays, the layout of which is inverted for opposite drive hands:

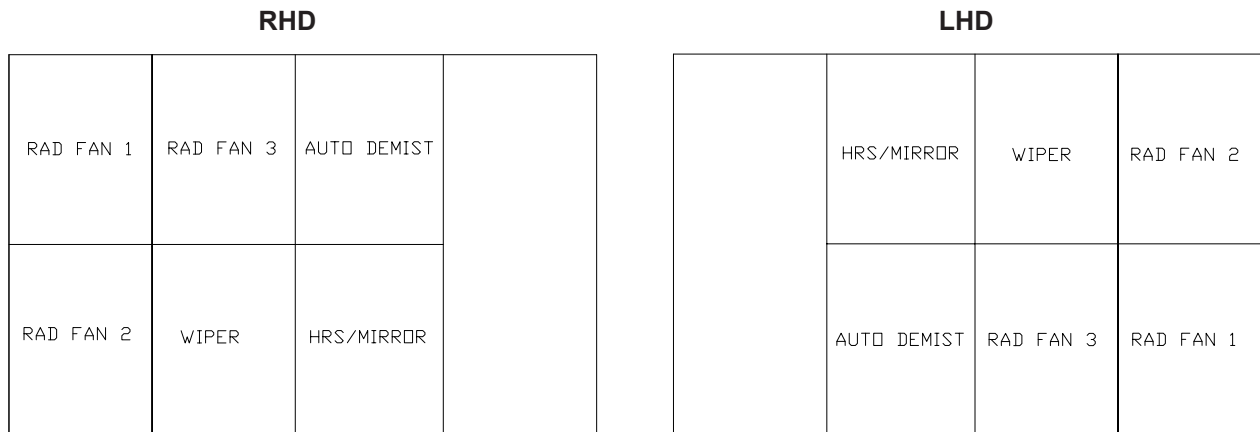

**Integrated Control Module**

Also mounted on the front fusebox panel is the integrated control module (ICM) which is used to perform switching and control functions for many of the circuits. The module uses 4 harness connector blocks designated A,B,C,D, with all connection details identified on the relevant circuit diagram, and summarised below:

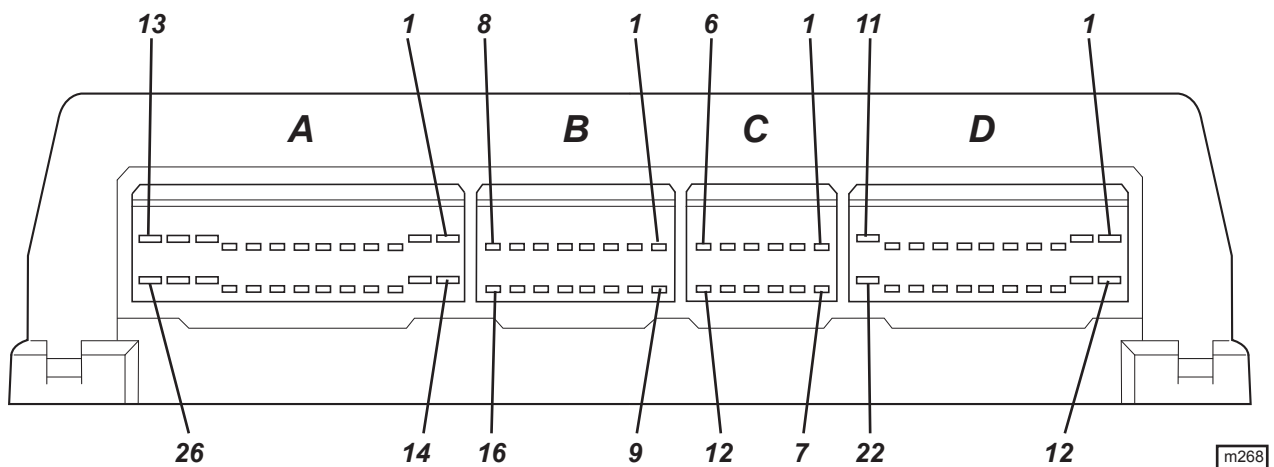



**Key to ICM Diagram**

<i>Pin</i>	<i>Description</i>	<i>Pin</i>	<i>Description</i>
A1	Supply for indicator relays	C1	Main beam flash power input
A2	Left indicators output	C2	Int. fan fast input
A3	-	C3	Fog switch illum. input
A4	-	C4	-
A5	Fog switch input	C5	Drive away locking output
A6	-	C6	Sidelights switch illum. output
A7	-	C7	HRS output
A8	Headlamp powerwash output	C8	Recirc. switch illum. output
A9	A.c. recirc. control output	C9	A.c. request output
A10	Supply for recirc. & powerwash control	C10	-
A11	Horn output	C11	-
A12	Supply for horn & foglamps	C12	Diagnostic comms. KW2000
A13	Supply for indicator current sense	D1	ICM main supply & main lighting
A14	Right indicators output	D2	-
A15	Battery ground	D3	HRS switch illumination
A16	-	D4	Ignition switch input
A17	-	D5	Headlamp relay output
A18	-	D6	Hazard switch illumination
A19	LED lighting option input	D7	Hazard active illumination
A20	Left indicator switch input	D8	A.c. switch illumination
A21	Right indicator switch input	D9	Headlamps switch illum. output
A22	Intermittent variable input	D10	-
A23	DRL option input	D11	Door open output
A24	Battery ground	D12	Sidelights output
A25	Fog lights output	D13	Main beam solenoid output
A26	Indicators supply after current sensing	D14	Int. fan speed input
B1	Main beam flash input	D15	Horn switch output
B2	Recirc. switch input	D16	-
B3	Hazard switch input	D17	Eng. man. rpm input
B4	Wiper int. input	D18	Wiper park input
B5	Washer monitor input	D19	Wiper relay control output
B6	HRW switch input	D20	Auto demist input
B7	A.c. request switch input	D21	Indicators fault monitor input
B8	Driver door switch input	D22	-
B9	CDL switch illumination		
B10	CDL switch monitor		
B11	Lock status input		
B12	Unlock status input		
B13	-		
B14	Passenger door switch input		
B15	Headlamp switch input		
B16	Sidelamps switch input		



Rear Fusebox

Fuses and relays for the engine bay and rear mounted systems are contained in a fusebox mounted in the cabin, behind the left hand rear quarter trim panel. For access, use a coin to release the quarter turn fastener on the lower edge of the removable panel, and unhook the top edge. Twenty slots are provided for mini fuses which are numbered, and coloured according to their amperage rating, and may be pulled out from their slots using the fuse extractor tool clipped to the fusebox. Two maxi fuses protecting major circuits are also provided, along with four single contact change over micro relays, and two power relays.

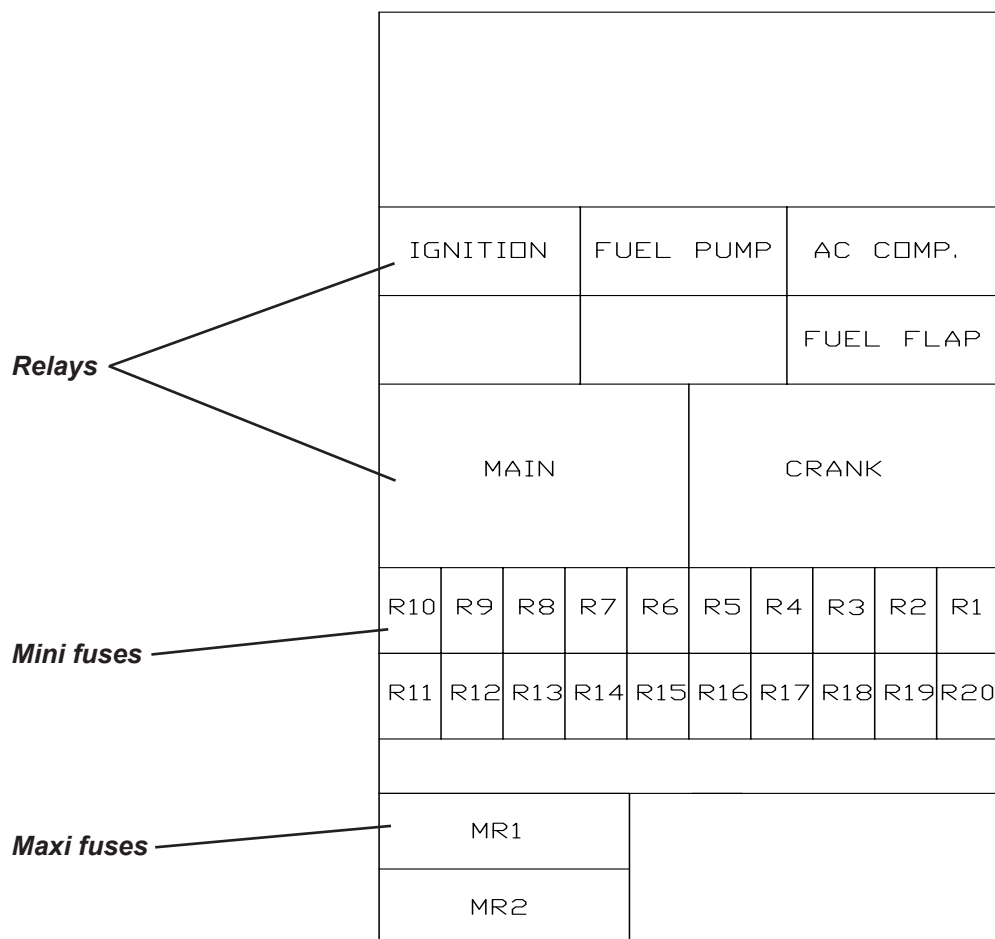

ohe25

Slot Rate Circuit

R1	10A	ECU, fan relay 3
R2	7.5A	Injectors
R3	10A	Ignition coils
R4	2A	Re-circ. pump
R5	-	
R6	-	
R7	5A	ECU ignition
R8	7.5A	Engine solenoids
R9	5A	O2 heaters
R10	5A	Alternator ign.

Slot Rate Circuit

R11	7.5A	A.c. compressor
R12	3A	Rev lamp, camera
R13	-	
R14	-	
R15	3A	Boot lamps
R16	10A	Boot pwr. socket
R17	20A	Amplifier
R18	5A	Fuel filler flap
R19	10A	Fuel pump
R20	5A	Alternator B+

Slot Rate Circuit

MR1	30A	Crank & main rly.
MR2	30A	Busbar R17-R20

Fuse colours

2A - Black	5A - Orange	15A - Light blue
3A - Violet	7.5A - Brown	20A - Yellow
4A - Pink	10A - Red	25A - Clear



## Component Location

Other electrical components may be found as follows:

- CDL module; passenger side of scuttle beam vertical face.
- Alarm components; see sub-section MR.1.
- Horns; one beneath the front end of each front longeron, aligned with apertures in the air intake duct. Accessible after removal of front undertray.
- Ambient air temperature sensor; mounted in RH side of the air intake duct, clipped to the undertray pylon. Accessible after removal of front undertray.
- Audio speaker cross-over units; one on each end of the scuttle vertical rear face.
- Forward crash sensor; one on the outboard face of each front subframe longeron, towards the front. Accessible after removal of the front undertray.
- Engine management components; see section EMR.
- TPMS module; in boot, on back of LH wheelarch.
- Reversing camera module; in boot, on LHS of rear transom.

## MR.7 - AUDIO EQUIPMENT

Operating instructions for the unit fitted are contained in a separate booklet supplied by the equipment manufacturer. The audio set will operate with the ignition key inserted, and in any of its positions, including the '0' lock position.

On cars fitted with a 2-DIN audio system and 175mm display screen, the following features are also included:

- AM/FM radio;
- CD audio;
- DVD video, operable only with the parking brake engaged;
- i-pod to i-pod video interaction/control;
- MP3 player;
- Satellite navigation;
- Integrated microphone for Bluetooth phone operation;
- When set is switched on, automatic display from reversing camera when reverse gear is engaged.
- Note that the screen should be cleaned occasionally with a lint free, spectacle polishing cloth.

### Note

- The 'satnav' system includes a road network safety camera database, which may be activated at the owner's request when the system is set up. If using the vehicle in territories where such a feature is illegal, it is the owner's responsibility to ensure that the system is de-activated.
- Note that the quality of radio reception will vary according to audio equipment fitted and local area signal strength.

*Speakers:* A main speaker is fitted into each of the door trim panels, and a high frequency 'tweeter' incorporated into each end of the dash fascia panel. In addition, some cars are fitted with a single sub-woofer, low frequency speaker in the right hand rear quarter trim panel.

*Door speakers - Alpine LUK-SB01B (4-speaker base spec.):*  
145mm aperture, 63mm depth

*Door speakers - Alpine LUK-SB02T: (4/5-speaker high spec.):*  
145mm aperture, 63mm depth

*Sub-woofer - Alpine SWE 843 (5-speaker high spec.):*  
183mm aperture, 111mm depth

*Tweeters - Alpine LUK-ST01:*  
42mm aperture, 12mm depth

*Security:* Some audio sets feature a removable front panel; For details, refer to the set manufacturer's literature.



## MR.8 - BATTERY, BATTERY CABLES & EARTHING POINTS

### Battery

**WARNING: POISON/DANGER - CAUSES SEVERE BURNS - KEEP OUT OF REACH OF CHILDREN.**

**Contains sulphuric acid - avoid contact with skin, eyes or clothing. If in contact with skin or eyes; flush with copious amounts of water. Remove contaminated clothing. Seek immediate medical attention. If ingested; seek immediate medical attention. Do not induce vomiting or give fluids to drink.**

**Batteries produce explosive gases. Keep sparks, flames and cigarettes away. Ventilate when charging or using in enclosed space. Always shield eyes when working near batteries.**

### Battery Access

The 72 Ah VARTA BLUE *dynamic* battery is located at the left hand front of the rear luggage compartment, protected by a plastic cover. No routine inspection or topping up of the electrolyte is required, but at intervals specified in the Maintenance Schedule, the battery terminals should be checked for security and condition, and protected with petroleum jelly.

To remove the battery, release the three thumbscrews and remove the plastic cover. Release the two screws and remove the retaining clamp from the base of the battery. Withdraw the battery sufficiently to allow the cables to be disconnected (see below).

When lifting out the battery, be aware of the considerable weight, and take all appropriate precautions to safeguard personal health.

Refit the battery, with its terminals to the rear, by reversing the above procedure. Remember to push on the breather pipe (if applicable).

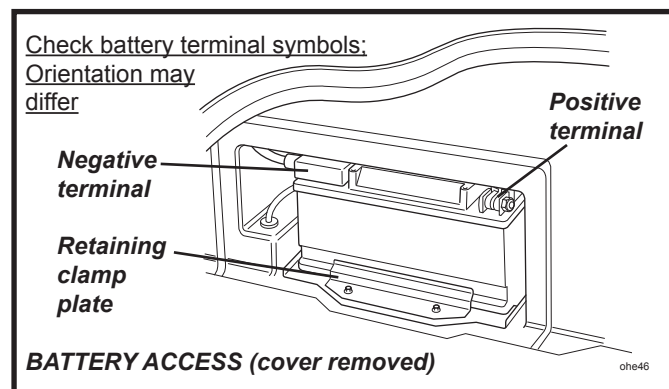

### Disconnecting the Battery

If the battery is to be disconnected, the following precautions should be taken:

- If the vehicle is fitted with security coded audio equipment, check that the code is available for entering after battery reconnection.
- Wait for at least ten seconds after switching off the ignition to allow the engine management system to adjust the setting of some components ready for re-starting.
- Ensure that all electrical loads (e.g. lights) are switched off.
- Check that the security alarm is disarmed. If the battery is disconnected when armed, the alarm will be triggered.
- Disconnect the **negative** (earth; black; '-') battery cable first, and re-connect last. If the battery positive terminal is inadvertently earthed (e.g. when using a spanner) whilst the negative terminal is still connected, the resultant short circuit with heavy sparking and current flow could cause serious burns.

### Battery Reconnection

- Check again that all electrical loads are switched off.
- Connect the positive battery cable first, followed by the negative (earth) cable.
- Be aware that the vehicle security alarm may be triggered by the action of battery re-connection. Have the alarm transmitter key ready to disarm the alarm (see 'Vehicle Security Alarm').
- After reconnection, a change in the engine performance characteristics may be noted for a period whilst the computer controlled engine management system 're-learns' some of its settings.
- If necessary, enter the security code into audio equipment.

### Battery Charging

Under conditions of normal daily use, it should not be necessary to use external battery charging equipment. In a low usage regime, however, it is important to maintain the charge state of the battery using a trickle charger, or an automatic battery management conditioner such as that available through Lotus After Sales.



Starting difficulties may be encountered after an unattended period of 3 weeks. A battery conditioner is able to continuously monitor battery charge state and switch on and off automatically in order to maintain the battery in a fully charged condition without danger of damage through overcharging.

If the battery becomes discharged to the extent that the car cannot be started, the recommended course of action is to fit a substitute battery whilst the original battery is trickle charged. If, in an emergency, the car has to be 'jump' started, the subsequent conditions of car use may not allow for sufficient alternator charging of the battery to achieve a fully charged state. The battery should be trickle charged by external means until 12.8 volts is recorded, which process may take 24 hours or longer. Putting the battery into service at a lower state of charge will reduce the time period for which the car can be parked without subsequent starting concerns. A battery left in a fully discharged state for a prolonged period, may not be recoverable to its original condition.

Unless using an automatic battery management charger, the battery should be removed from the car for recharging, to a well ventilated area to avoid a build up of fumes in the luggage compartment and to prevent damage to the car's electrical system. Observe the safety precautions listed above when removing the battery and take care to avoid sharp knocks or shocks, keeping the battery as upright as possible. Beware of the considerable weight of a battery, and take necessary precautions against personal injury.

The recommended bench charge rate is 4 amps. When the battery is fully charged (12.8 volts), allow it to stand for an hour before refitting into the battery well and reconnecting the leads - see above.

### Quiescent Drain

With a fully charged battery, a car with no aftermarket electrical equipment fitted, all electrics switched off, and the alarm system either armed or disarmed, will have a quiescent current drain of between 27 - 32 mA dependent on audio and sat. nav. options. Under normal conditions, this should allow a park period of over four weeks before starting difficulties may be encountered.

If current drain is found to significantly exceed specification, the cause must be established by isolating components (e.g. at fusebox) and rectifying faults as necessary.

### Battery Cables

Two red cables are connected to the battery positive post. One leads to the solenoid on the starter motor. A second cable leads to the positive post fixed to the back of the cabin bulhead in the LHR wheelarch area, and includes an 'in-line' 150A fuse. This post is linked via a cable routed through the LH sill area to the front mounted positive post on the top of the passenger side scuttle, and from here to the main fusebox/relay panel at the front of the passenger footwell.

A braided earth cable connects the negative battery terminal to the chassis rear earth point, on the inside face of the LH siderail, at the LHF of the engine bay, accessible from beneath. Two further cables link this point to the transmission casing, and to the rear fusebox and ECU mounting bracket at the LHR of the cabin.

**WARNING: Before disconnecting a live feed cable from either post, first disconnect the earth cable from the battery. Be aware of the danger of short circuits and sparks caused by a live feed cable contacting the chassis or other metal components.**

The rear positive post is mounted on a bracket which also secures the left hand end of the evaporative emissions canister, and is accessible with the wheelarch liner and/or rear clamshell removed. Special care should be taken to prevent sparks in this area. When re-connecting the rear positive post, note that two spacers A075W4020Z should first be fitted onto each stud, before each pair of cables is assembled back to back, with the battery and front fusebox cables on the front stud, and the alternator and rear fusebox cables on the rear stud. Tighten the M8 retaining nuts to 16 Nm.

### MR.9 - WIPER MECHANISM

The windscreen wiper mechanism comprises a uni-directional motor with an external rotary link, a connecting rod, and a pair of actuating links which join the connecting rod to the arms of the wiper spindle. This mechanism provides the wiper with a motion which is slowed at each end of its travel in order to ease the inertia loads during direction changes, to the benefit of refinement and durability. The motor and wheelbox are mounted on a single pressed steel bracket which is bolted to the underside of the windscreen frame.



### To remove the wiper mechanism:

1. Remove the front clamshell (see sub-section BV.4).
2. Remove the wiper arm.
3. Remove the 4 retaining screws, and withdraw the windscreen gutter with drain tubes.
4. Unplug the harness connector from the wiper motor. Release the 4 cap head screws around the wiper spindle that secure the mounting bracket to the windscreen frame, and the single screw at the motor end of the bracket. Withdraw the wiper mechanism.
5. Re-assemble in the reverse order to removal, torque tightening the bracket bolts to 20 Nm.

Note that no service parts are offered for the wiper mechanism. Excessive wear in any part of the mechanism, or motor is rectified by renewal of the complete assembly.

### MR.10 - HARNESS ROUTING

The main harness runs from the main fusebox/relay station at the front of the passenger footwell, up to the center underside of the scuttle, across to the passenger side and through to the top of the scuttle. Then it runs across the full width of the scuttle to supply all the fascia components and to each of the separate door harnesses. At the centre of the front bulkhead, a branch of the main harness penetrates the bulkhead and divides along each side to supply the HVAC functions, ABS, lighting and other front mounted electrical equipment. From the same junction at the front bulkhead, a further branch runs down the centre of the cockpit, beneath the gearchange mounting channel to supply the fuel pump, with branches also running to each side behind the seat mounting front cross-member and back to each rear quarter area. The RH branch supplies the roof harness near the 'B' post area and continues through the rear bulkhead to supply the tailgate and rear lighting harnesses. The LH branch connects to the engine management ECU and engine harness, then continues through the bulkhead to supply the parking sensors and TPMS.

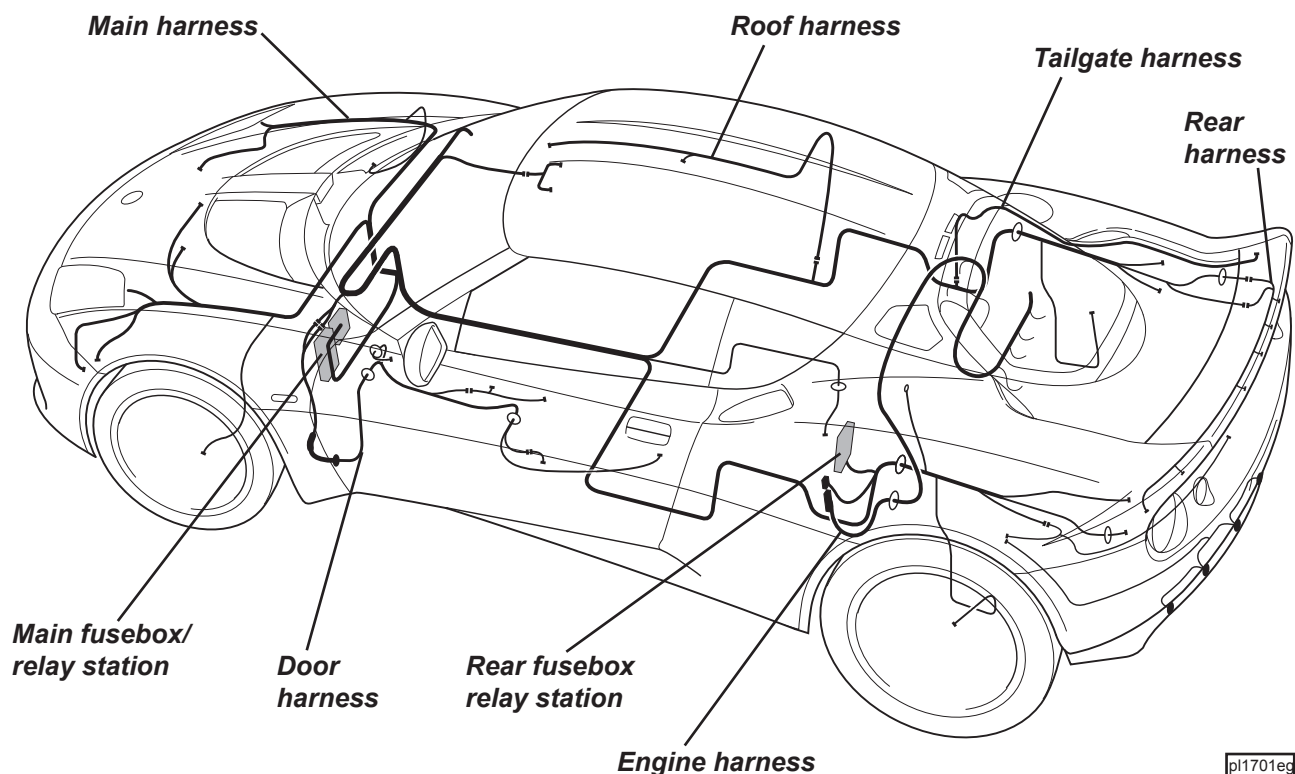

pl1701eg



## MR.11 - HEADLAMP ASSEMBLIES

### Xenon Headlamp Assemblies

The Lotus Evora is available with High Intensity Discharge (HID)/Xenon headlamp assemblies, the light sources of which utilise a plasma discharge arc between two electrodes to provide a blue-white light for optimal illumination of the roadway. Each headlamp unit uses a D1S electronic igniter/burner unit (equivalent to the bulb), mounted in a specially coated alloy reflector, ahead of which is fixed a glass aspheric lens on an alloy carrier. A shielded high tension harness connects the burner unit to a voltage ballast unit mounted in the base of the headlamp housing. The ballast unit is supplied with battery voltage and outputs around 20,000 volts (up to 80,000 during the start up phase) to the burner, although the power consumption is only 35 Watts.

A bottom pivoted flap is used to mask the upper part of the light beam (i.e. lower part in front of the lamp, prior to beam inversion by the aspheric lens), and allow a single light source to provide both main and dip beams. The flap is sprung and counterweighted in order to default to the vertical, masking, position, and is swung down by a solenoid fixed to the side of the reflector unit, when main beam is selected. Also contained within each headlamp housing is a 10 LED sidelamp, positioned outboard of the headlamp, and an 8 amber LED turn lamp at the front of the housing, fronted by a clear diffuser.

Due to the increased light production of the gas discharge headlamps, and the increased potential for dirt on the lamp cover causing dazzle from refraction, a powerful headlamp washer is fitted. A dedicated high pressure pump is fitted into the windscreen washer bottle, and supplies a powerwash module incorporated into the outer side of each headlamp unit, normally lying flush with the headlamp cover. When the windscreen washer control is operated, the headlamp washer pump is also activated for 2 seconds, the pressure from which causes the telescopic washer module to extend about 20 mm above the headlamp cover and deploy two conical sprays of fluid from a pair of high flow jets. The module then returns under spring action to its flush position.

Note that certain atmospheric conditions may result in some condensation inside the lamp unit. This should have no significant effect on lamp performance and is no cause for concern.

### Headlamp Servicing

The only serviceable parts of the Xenon headlamp unit are:

- D1S burner unit
- Voltage ballast unit
- Powerwash module
- High tension cable

### **WARNING:**

**The high voltages produced by the headlamp ballast unit could cause injurious electric shocks. Ensure the battery is disconnected before servicing the headlamp assembly.**

To replace the burner unit, first disconnect the battery to protect from potentially injurious shocks. Remove the access grommet in the wheelarch liner, and pull off the protective boot from the back of the headlamp housing. Release the spring wire clip and withdraw the burner sufficiently to allow the H.T. cable to be unplugged. Note that touching the glass envelope by hand is likely to lead to premature failure. If necessary, the envelope should be cleaned using white spirit and a paper tissue.

Other serviceable parts may be replaced after removing the headlamp housing from the car.

### Halogen Bulb Headlamp Assemblies

The Evora is also available with halogen bulb headlamp assemblies, which share the same housing and features of the Xenon units, but are replace the HID headlamp equipment with a simpler H4 halogen bulb.

### Headlamp Housing Removal

Each headlamp is secured to the front subframe longeron via front and rear mounting brackets. To remove a headlamp housing:

1. Remove the front roadwheel and wheelarch liner;
2. Disconnect the wiring harness and washer tubing;
3. Release the two screws securing the headlamp front mounting bracket to the subframe, and the two fixings securing the headlamp rear bracket to the bumper support bracket. Withdraw the headlamp assembly.



4. When re-fitting, ensure the front clamshell is first fitted and optimised for position before adjusting the headlamp mounting to obtain a satisfactory fit of the lamp in the aperture.
5. Re-connect the harness and washer tubing and check headlamp beam alignment.

### Headlamp Beam Alignment

1. Using beam setting equipment compatible with local regulations, position the machine between 300 and 700mm in front of the LH headlamp, and parallel with the two headlamp units using the sight bar or similar device dependent on the machine design, to ensure cross car match. Use the guides provided on the machine to ensure the correct height and lateral setting.
2. Switch on the headlamp dip beams and check the lateral beam alignment. The 'knee point' of the beam cut off line must lie within a tolerance of 2% to the passenger side, and 0%. Check the vertical alignment of the dip beam which must lie within a tolerance of -0.5% and -2%.
3. If adjustment is required, turn the steering to full lock to facilitate removal of the four screws retaining the access cover in the wheelarch liner.
4. Each headlamp assembly features two adjustment screws, one for vertical, and one for horizontal aim. To adjust the beam laterally, turn the inboard adjuster screw. Turn clockwise to adjust the beam to the right. Optimum setting is 0%. To adjust the beam vertically, turn the outboard adjuster screw. Turn clockwise to raise the beam. Optimum setting is -1.2%. Re-check lateral alignment.
5. Repeat for the opposite lamp.
6. Re-fit the access cover in the wheelarch liner.

### MR.12 - BULB REPLACEMENT

#### Headlamp Units

##### *Halogen Headlamps (if fitted)*

On cars fitted with halogen headlamp assemblies, the lamps are fitted in the same housings as used for the HID headlamps: Remove the access cover in the wheelarch liner, and pull off the protective boot from the back of the headlamp housing. Pull the harness plug off the bulb, release the spring wire retaining clip, and withdraw the bulb. Note that touching the glass envelope by hand is likely to lead to premature failure. If necessary, the envelope should be cleaned using white spirit and a paper tissue.

##### *HID Xenon Headlamps (if fitted)*

Each HID headlamp unit uses a D1S electronic igniter/burner unit (equivalent to the bulb), mounted in a specially coated alloy reflector, with a ballast unit to output around 20,000 volts to the burner.

**WARNING: The high voltages produced by the headlamp ballast unit could cause injurious electric shocks. Ensure the battery is disconnected before servicing a headlamp assembly.**

1. Disconnect the battery to protect from potentially injurious shocks. Remove the access cover in the wheelarch liner, and pull off the protective boot from the back of the headlamp housing.
2. Release the spring wire clip and withdraw the burner sufficiently to allow the H.T. cable to be unplugged. Note that touching the glass envelope by hand is likely to lead to premature failure. If necessary, the envelope should be cleaned using white spirit and a paper tissue.
3. After refitting, verify lamp operation and check that the protective boot is correctly fitted onto the lamp body before replacing the wheelarch liner grommet.

#### Front Turn Indicator & Sidelamp Bulbs

The front turn lamps and sidelamps are provided by light emitting diodes (LEDs) and are incorporated into





the headlamp assemblies. These lamps are designed for long life and are serviceable only by replacement of the complete headlamp unit.

### **Rear Lamp Cluster Bulbs**

The outboard lamp cluster contains the tail, brake and turn indicator functions, and is configured as follows:

Annulus; tail and brake lamps.

Centre; turn indicator lamp.

The tail and brake lamps are provided by a ring of light emitting diodes (LEDs), and are serviceable only by complete lamp cluster replacement. Each turn indicator lamp uses a filament type GE921 capless bulb retained in a bayonet type holder. From inside the boot, turn the bulb holder anti-clockwise to release from the lamp body, and withdraw the bulb.

### **Rear Fog and Reverse Lamps**

A secondary lamp is mounted inboard of each rear lamp cluster, to provide a rear fog lamp on the driver's side, and a reversing lamp on the passenger side. Both these lamps are sealed units containing a ring of LEDs, which are serviceable only by replacement of the complete lamp. Note that this process requires the rear bumper to be removed (see sub-section BV.7).

### **Centre High Mounted Stop Lamp (CHMSL)**

The CHMSL, mounted to the underside of the rear aerofoil, uses a string of light emitting diodes (LEDs) for optimum visibility. The lamp is a sealed unit with no replaceable bulbs, and may be replaced complete, after releasing the two retaining screws and unplugging the harness connector.

### **Side Repeater Lamps**

The side repeater lamps are mounted in the front clamshell behind each wheelarch, and use durable light emitting diodes (LEDs). The lamps are serviceable only by complete replacement, the lamp being secured by an adhesive gasket.

### **Licence Plate Lamps**

To replace a bulb in a rear licence plate lamp, first remove the two screws securing the lamp to the body, and withdraw sufficiently to allow access to the festoon bulb.

### **Interior Lamp**

To withdraw the interior lamp from the roof trim panel, first ease one end of the lamp from its aperture. Withdraw the lamp sufficiently to allow access to the festoon bulb, if necessary, unplugging the harness connector.

## **MR13 - INSTRUMENT PANEL**

The instrument panel is mounted on the Fascia Dash Panel, but may be removed separately:

1. Remove the instrument cowl top access panel by lifting the forward end free from its Griplock strips, and unhook the rearward end.
2. Unplug the harness connectors from the instrument panel. Release the two screws securing the top of the instrument panel to the cowl flange, and the two screws securing the back face of the unit to the support plate.
3. From within the coin pocket outboard of the steering column, remove the blanking sticker and release the switch panel fixing screw. Carefully prise the outboard switch panel out with its two Tower clips. Unplug the switch harness connector.
4. Carefully prise out the inboard switch panel with its four Tower clips and unplug the switch harness connectors.
5. Release the two screws securing the instrument panel to the fascia, and withdraw the unit.

MR.14 - CIRCUIT DIAGRAMS

<b>Circuit</b>	<b>Sheet</b>	<b>Page</b>
Battery Supply	A1	35
Accessory Key In	A2	36
Accessory Supply	A3	37
Ignition Supply	A4	38
Charging System	A5	39
CAN Network	A6	40
Diagnostic Link Connector	A7	41
Grounding Structure	A8	42
Cranking	B1	43
Alarm & Immobiliser	B2	44
Central Locking	B3	45
Fuel Filler Flap & Glovebox Solenoids	B4	46
EMS Power & Ground	C1	47
EMS Fuel Injection	C2	48
EMS Ignition Coils	C3	49
EMS TMAF & Knock Sensors	C4	50
EMS Cam & Crank Sensors & Various Solenoids	C5	51
EMS Coolant Sensing & Fan Control	C6	52
EMS Throttle Actuation	C7	53
EMS Fuel Pump & Fuel level Sensing	C8	54
EMS O2 Sensors	C9	55
EMS Cruise Control	C10	56
Sidelamps	D1A	57
Switch Illumination	D1B	58
Headlamps (Xenon)	D2A	59
Headlamps (Halogen)	D2B	60
Rear Fog Lamps	D3	61
Direction Indicators & Hazard Lamps	D4	62
Brake Lamps	D5	63
Reverse Lamps & Reversing Camera/Sensors	D6	64
Interior Lighting - LHD	D7A	65
Interior Lighting - RHD	D7B	66
Airbags	E1	67
Anti-Lock Brakes, Traction Control & Sport Mode	E2	68
Instrument Cluster	E3	69
HVAC System Part 1	E4A	70
HVAC System Part 2	E4B	71
HVAC System Part 3	E4C	72
Wash Wipe System. Power Wash & Heated Jets	E5	73
Window Lift with Active Glass (LHD)	E6A	74
Window Lift with Active Glass (RHD)	E6B	75
Tyre Pressure Monitoring	E7	76
Electric Mirrors & Heated Rear Screen (LHD)	E8A	77
Electric Mirrors & Heated Rear Screen (RHD)	E8B	78
ICE Base	E9A	79
ICE Tech Pack	E9B	80
ICE - Japanese	E9D	81
Horns & Power Sockets	E10	82
Homelink	E11	83

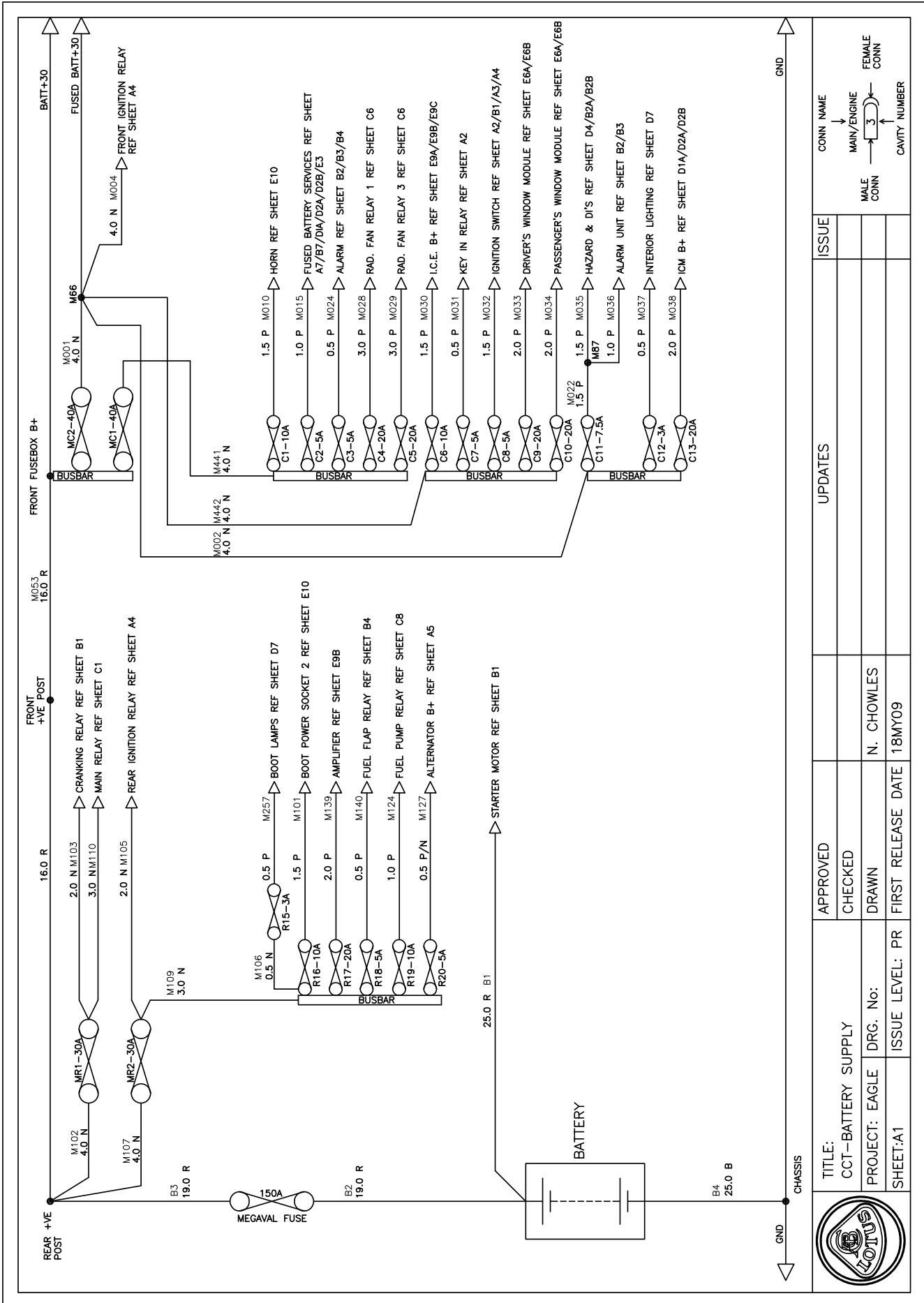

		<b>TITLE:</b> CCT-BATTERY SUPPLY		<b>APPROVED</b> 		<b>ISSUE</b> 	
<b>PROJECT:</b> EAGLE		<b>DRG. No:</b> N. CHOWLES		<b>CHECKED</b> 		<b>UPDATES</b> 	
<b>SHEET:</b> A1		<b>ISSUE LEVEL:</b> PR		<b>DRAWN</b> 		<b>CONN NAME</b> MAIN/ENGINE MALE CONN → 3 → FEMALE CONN CAVITY NUMBER	
<b>FIRST RELEASE DATE</b> 18MY09							

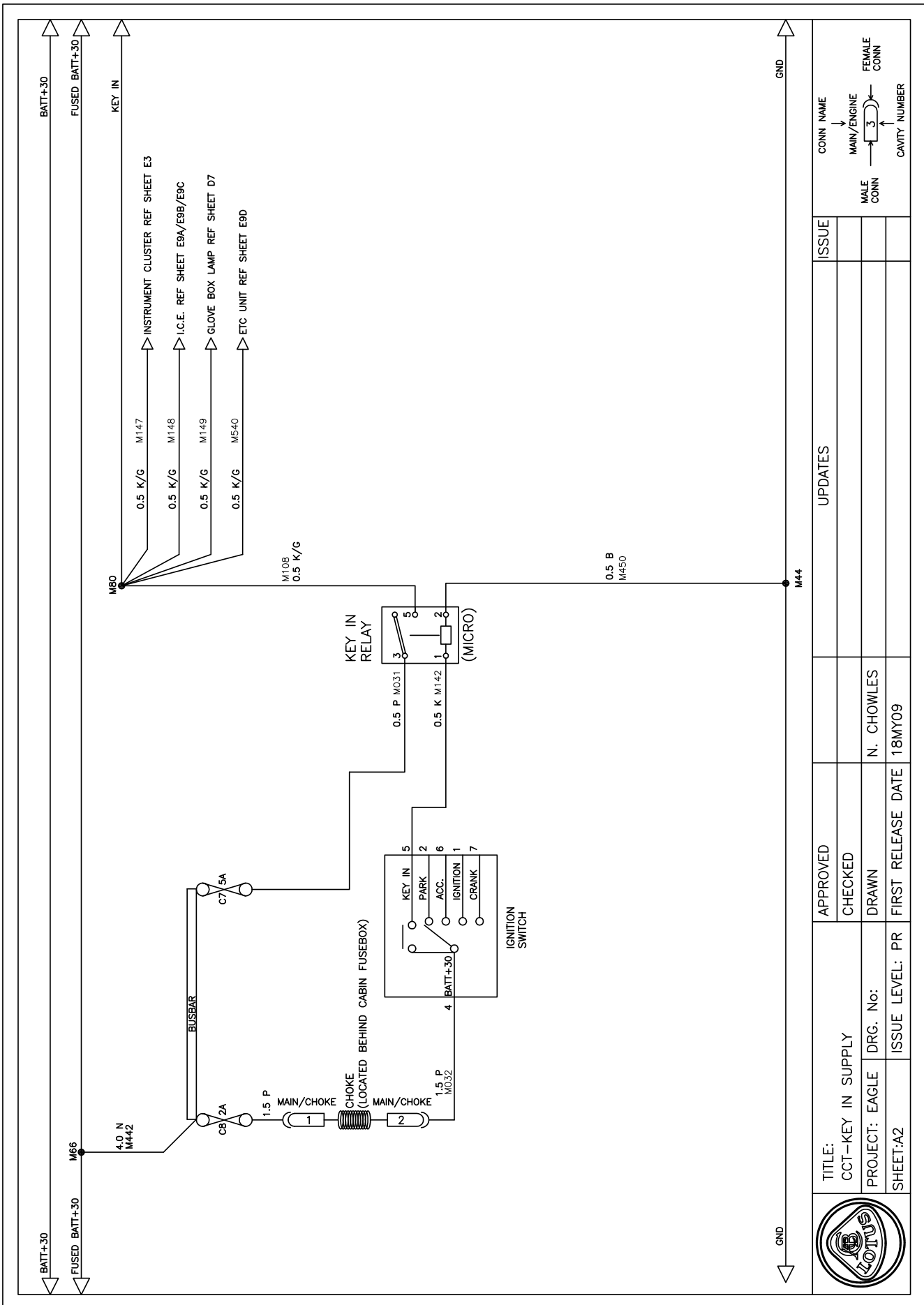

	TITLE: CCT-KEY IN SUPPLY	APPROVED	ISSUE	CONN NAME MAIN/ENGINE MALE CONN → 3 ← FEMALE CONN CAVITY NUMBER
	PROJECT: EAGLE DRG. No:	CHECKED	UPDATES	
SHEET:A2	ISSUE LEVEL: PR	DRAWN		
	FIRST RELEASE DATE	N. CHOWLES		
		18MY09		

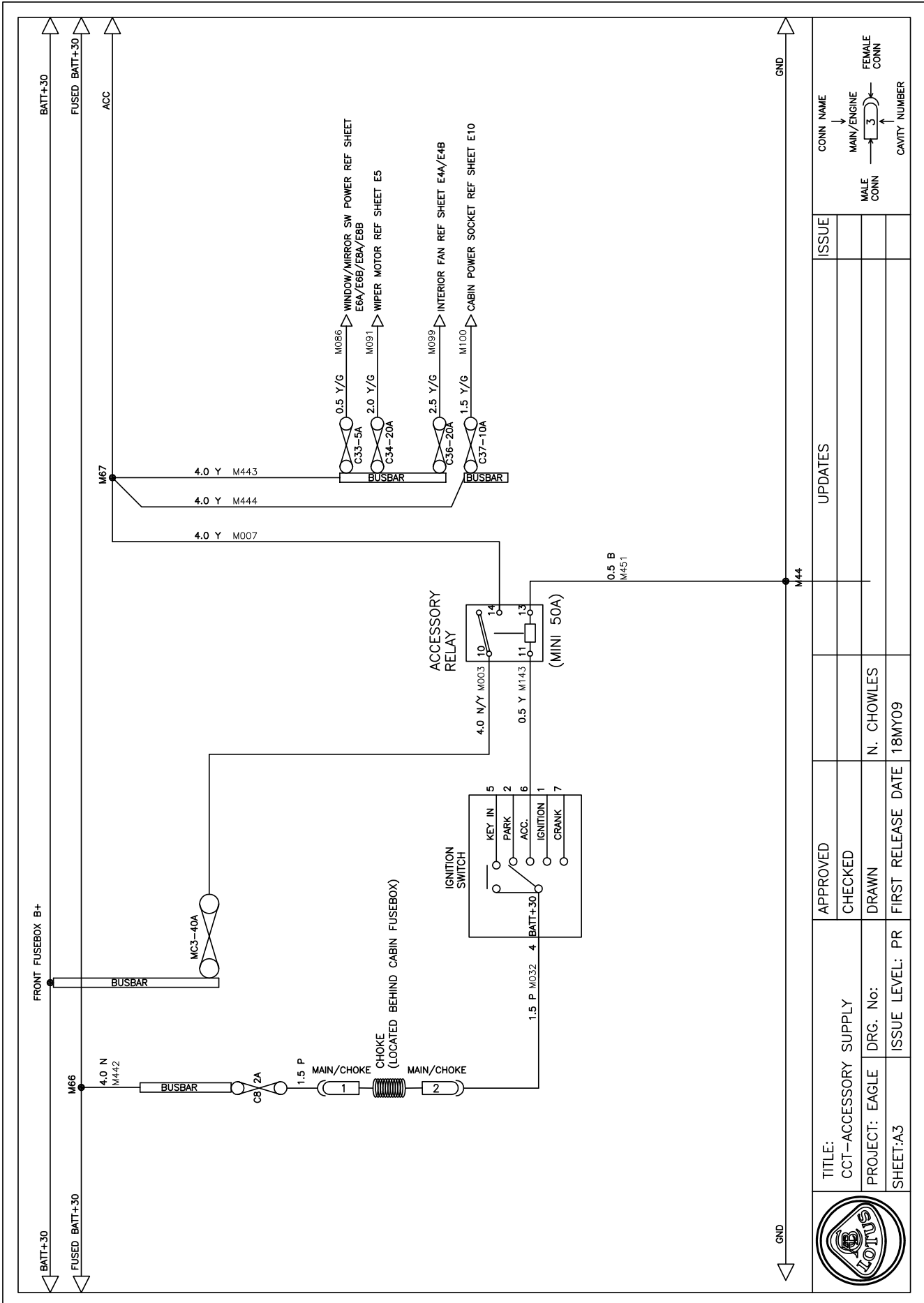

CONN NAME	MAIN/ENGINE	FEMALE CONN
MALE CONN	3	CAVITY NUMBER

ISSUE	UPDATES

APPROVED	
CHECKED	
DRAWN	N. CHOWLES
FIRST RELEASE DATE	18MY09

TITLE:	CCT-ACCESSORY SUPPLY
PROJECT:	EAGLE DRG. No:
SHEET:A3	ISSUE LEVEL: PR



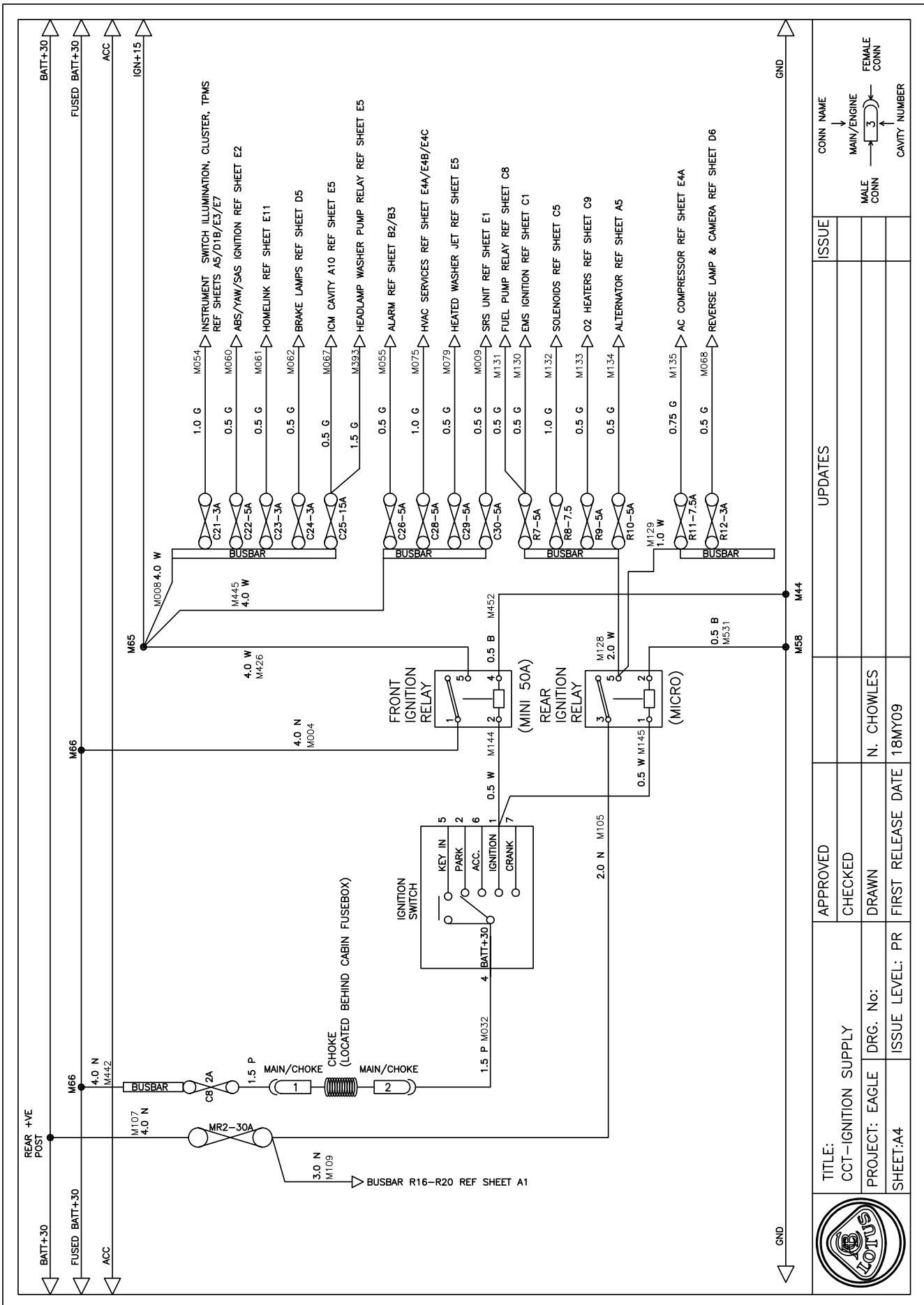

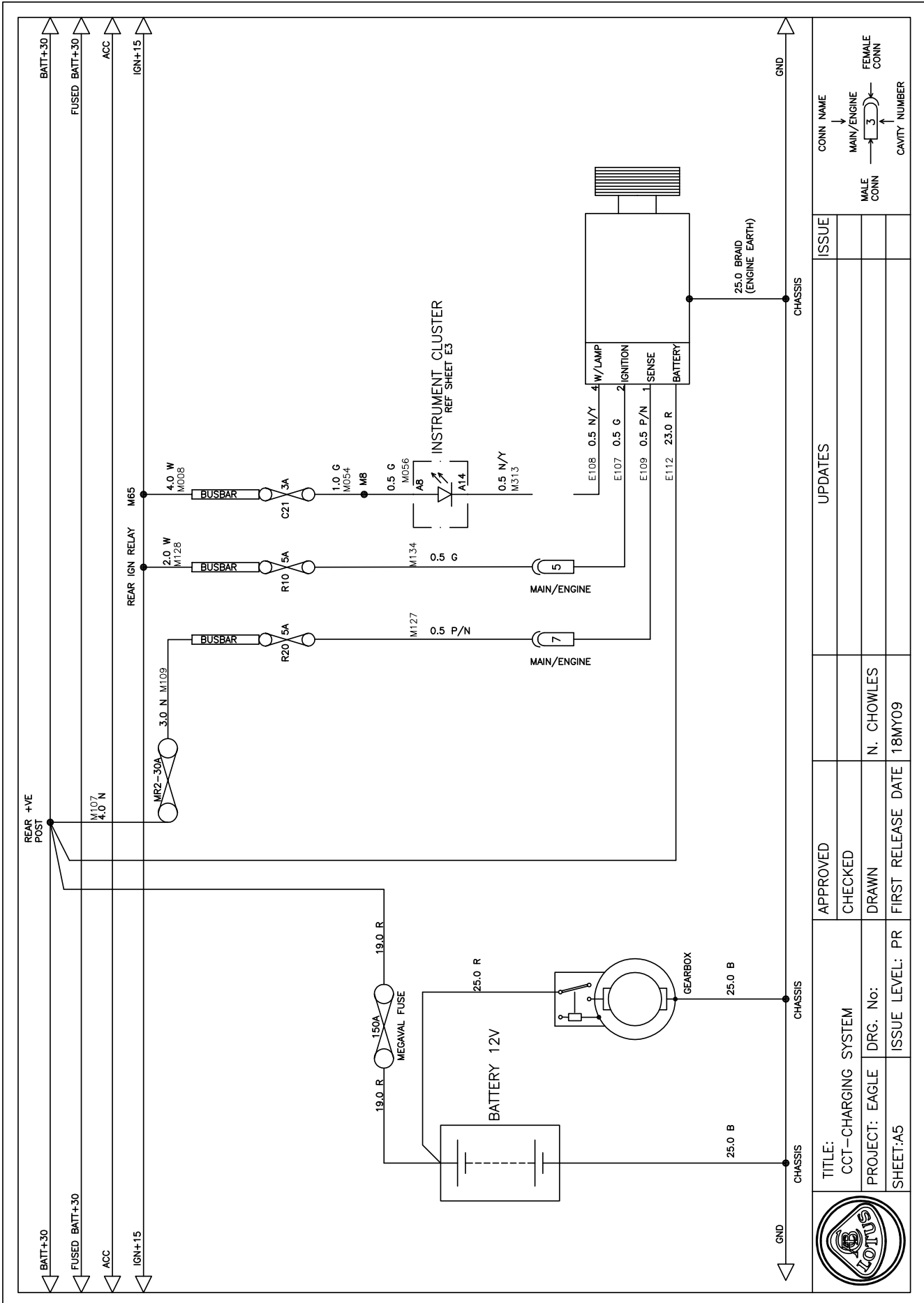

		<b>TITLE:</b> CCT-CHARGING SYSTEM		<b>APPROVED</b> CHECKED		<b>ISSUE</b>	
<b>PROJECT:</b> EAGLE		<b>DRG. No.:</b> N. CHOWLES		<b>DRAWN</b>		<b>ISSUE</b>	
<b>SHEET:</b> A5		<b>ISSUE LEVEL:</b> PR		<b>FIRST RELEASE DATE</b> 18MY09		<b>ISSUE</b>	
<b>CONN NAME</b> MAIN/ENGINE		<b>CONN</b> 3		<b>MALE CONN</b>		<b>FEMALE CONN</b>	
						<b>CAVITY NUMBER</b>	

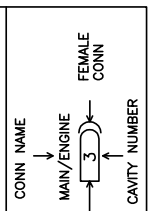
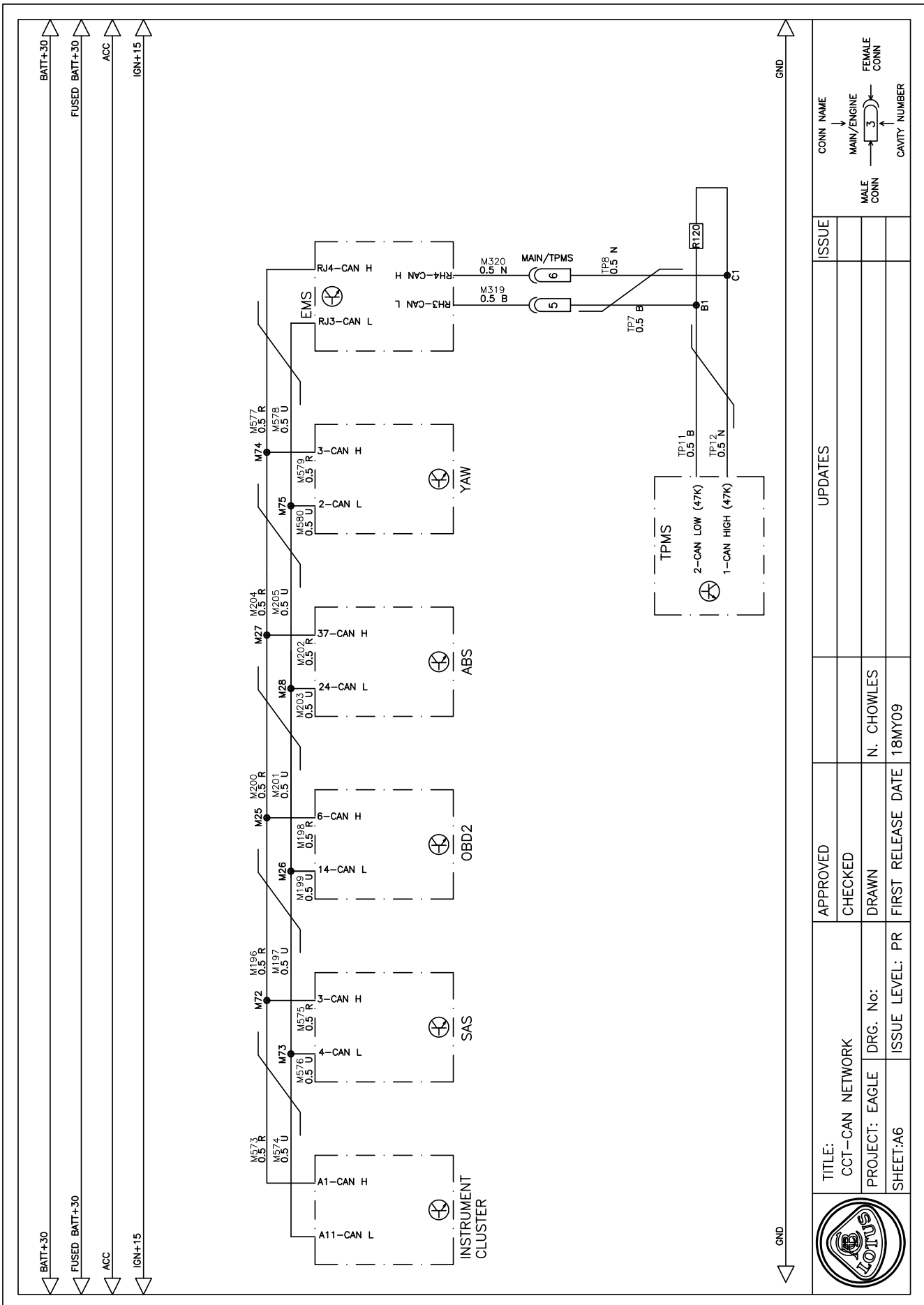

TITLE: CCT-CAN NETWORK	APPROVED	ISSUE
PROJECT: EAGLE	CHECKED	
SHEET:A6	DRAWN	
DRG. No:	FIRST RELEASE DATE	UPDATES
ISSUE LEVEL: PR	18MY09	
	N. CHOWLES	



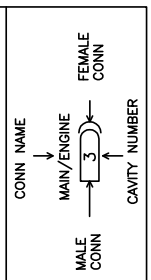
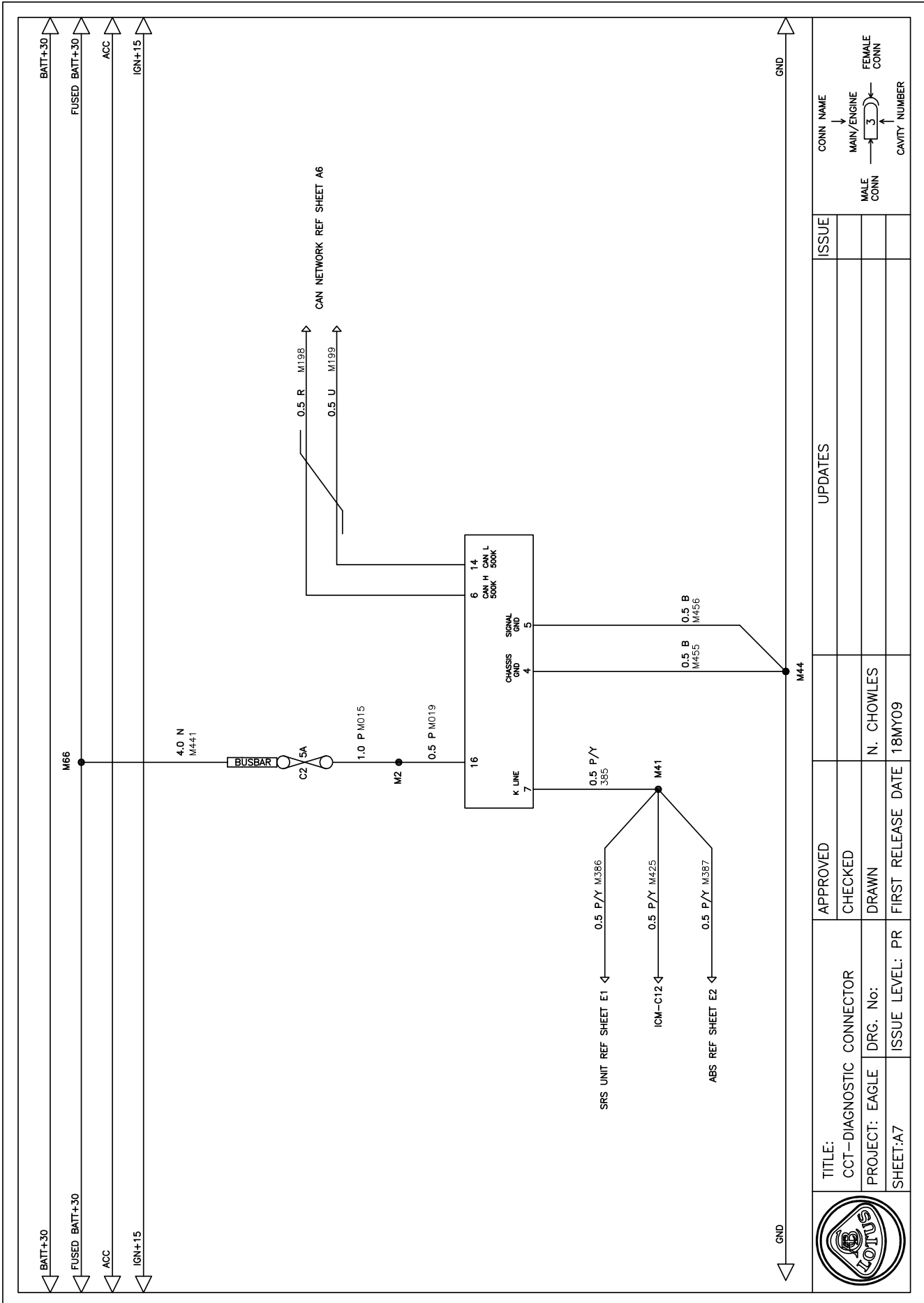

TITLE: CCT-DIAGNOSTIC CONNECTOR	APPROVED	ISSUE	UPDATES
PROJECT: EAGLE	CHECKED		
SHEET:A7	DRAWN		
DRG. No:	N. CHOWLES		
ISSUE LEVEL: PR	FIRST RELEASE DATE		
	18MY09		

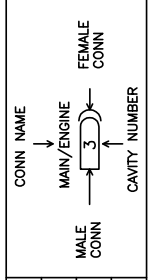
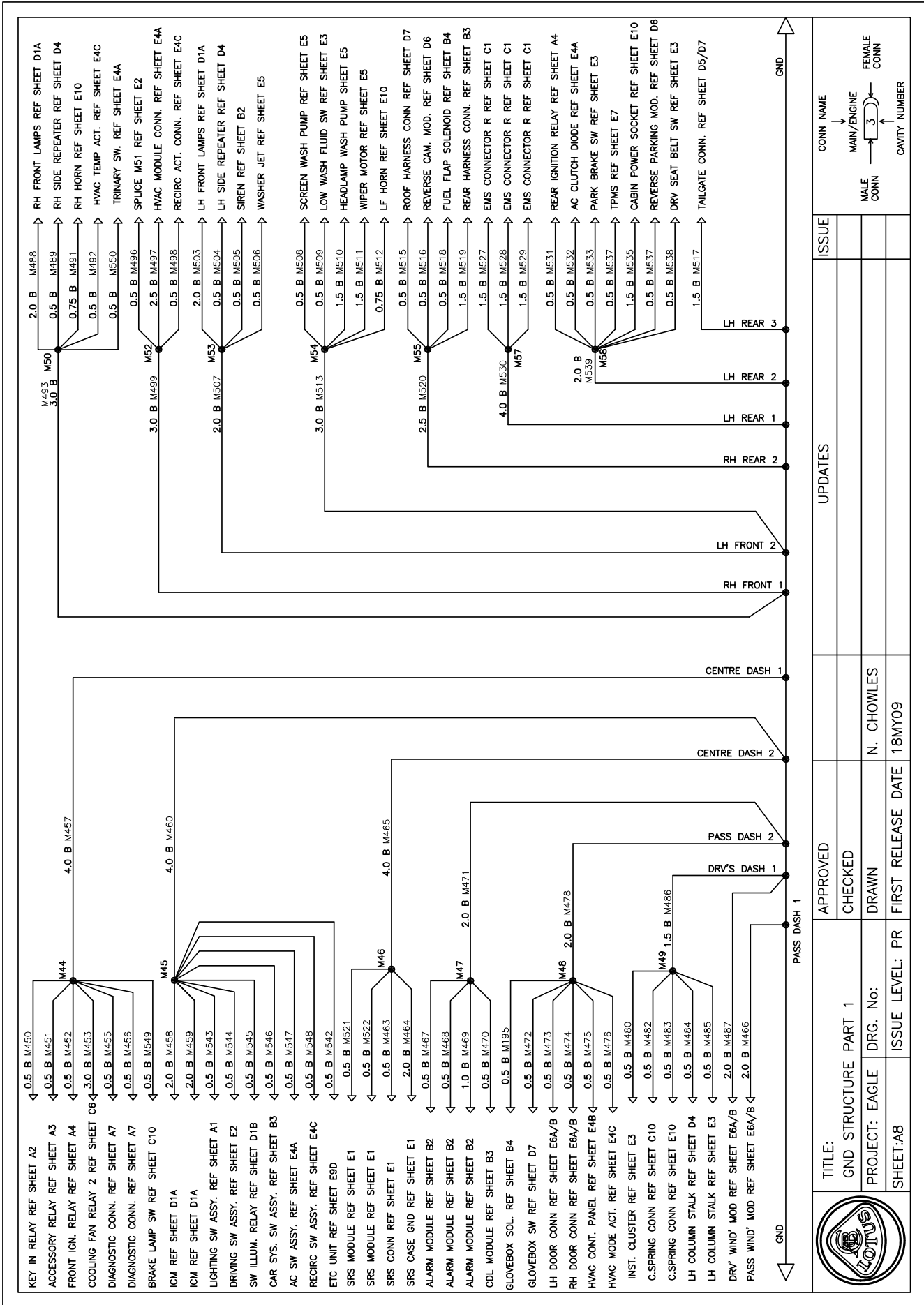

GND STRUCTURE PART 1		APPROVED		UPDATES		ISSUE	
PROJECT: EAGLE		CHECKED					
DRG. No:		DRAWN					
SHEET:A8		ISSUE LEVEL: PR		FIRST RELEASE DATE		18MY09	
		N. CHOWLES					



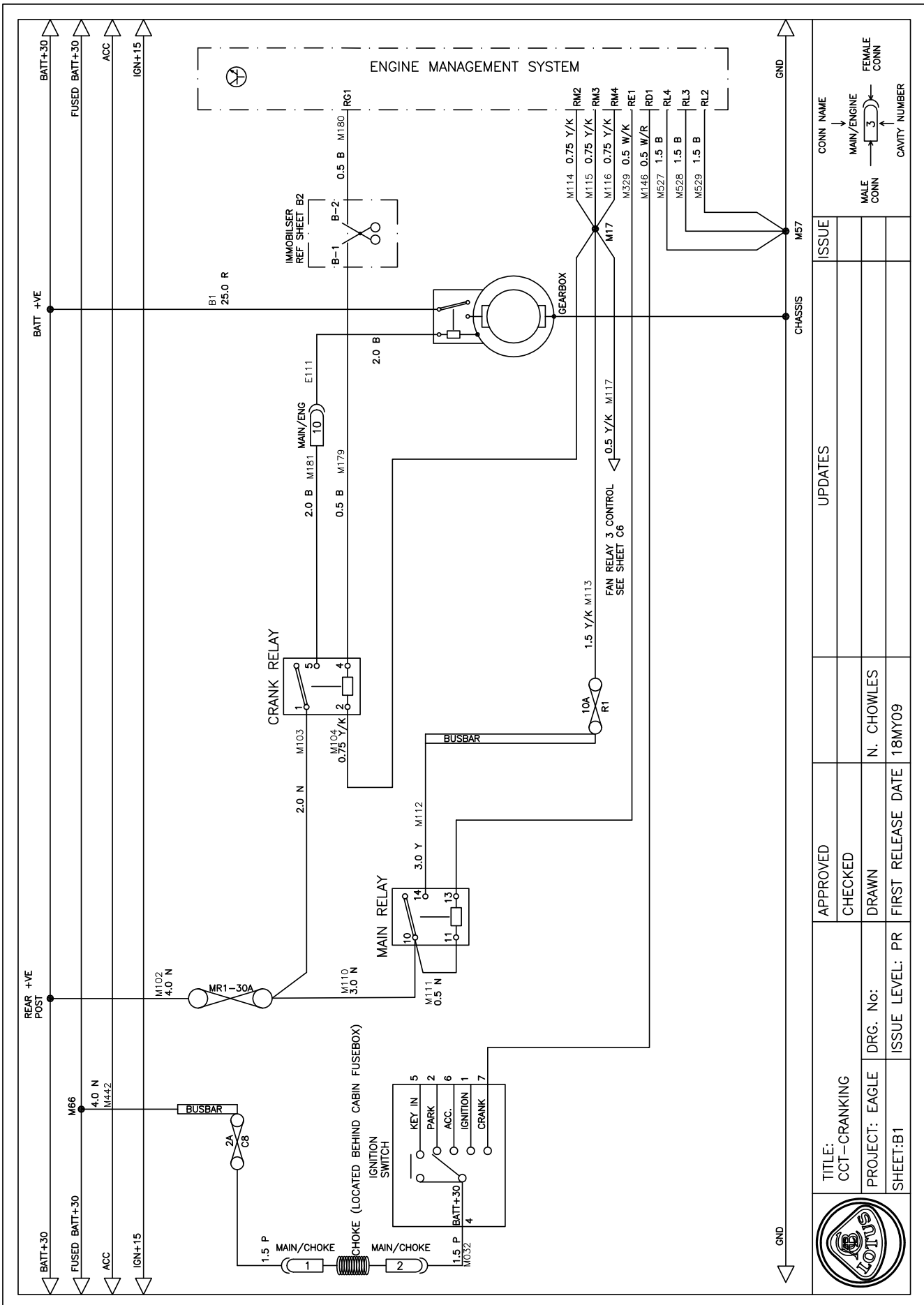

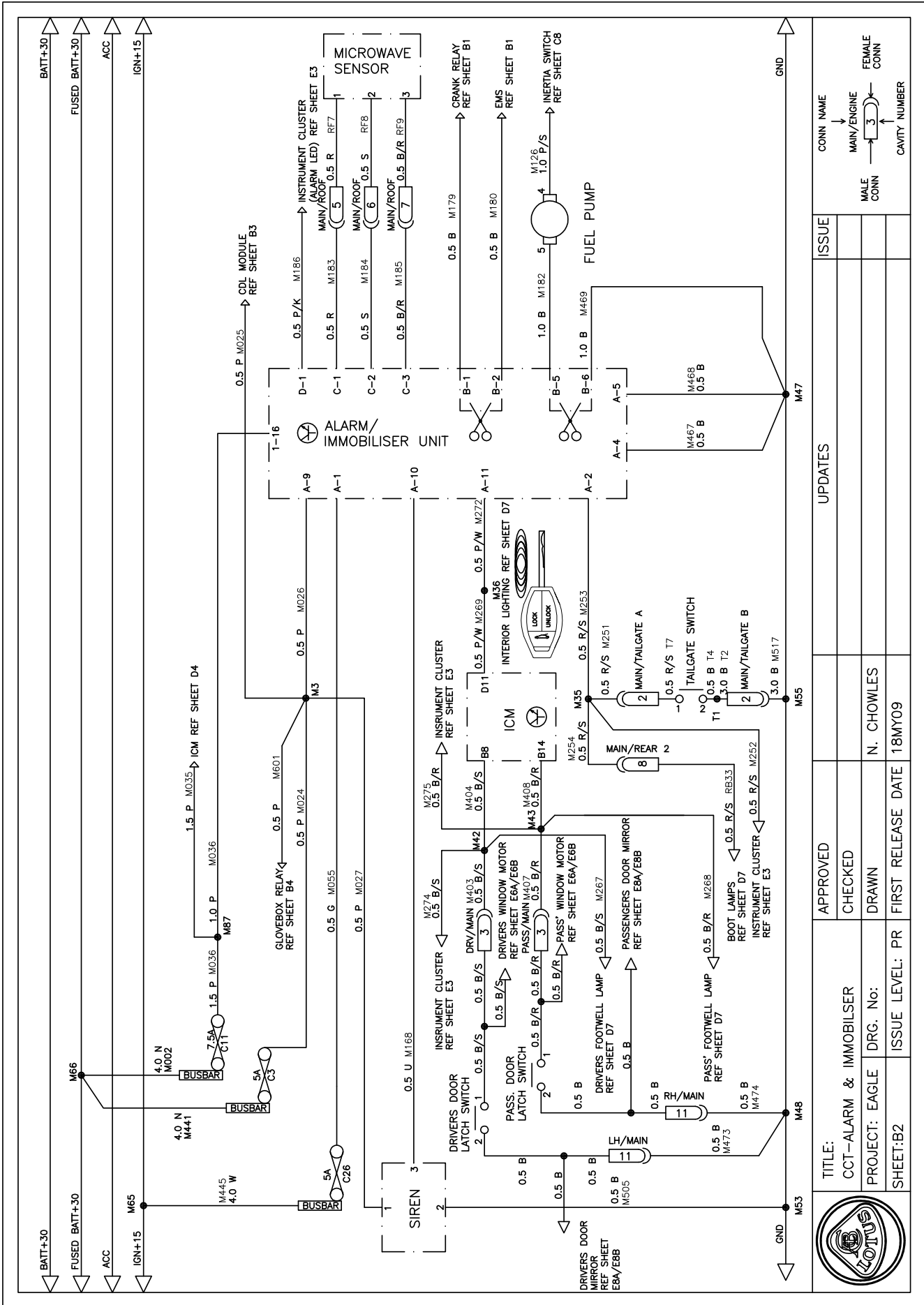

		<b>TITLE:</b> CCT-CRANKING		<b>APPROVED</b> [Signature]		<b>ISSUE</b> [Signature]	
<b>PROJECT:</b> EAGLE		<b>DRG. No:</b> N. CHOWLES		<b>CHECKED</b> [Signature]		<b>UPDATES</b> [Signature]	
<b>SHEET:</b> B1		<b>ISSUE LEVEL:</b> PR		<b>FIRST RELEASE DATE</b> 18MY09		<b>CONN NAME</b> MAIN/ENGINE	
				<b>MALE CONN</b> → 3		<b>FEMALE CONN</b> CAVITY NUMBER	

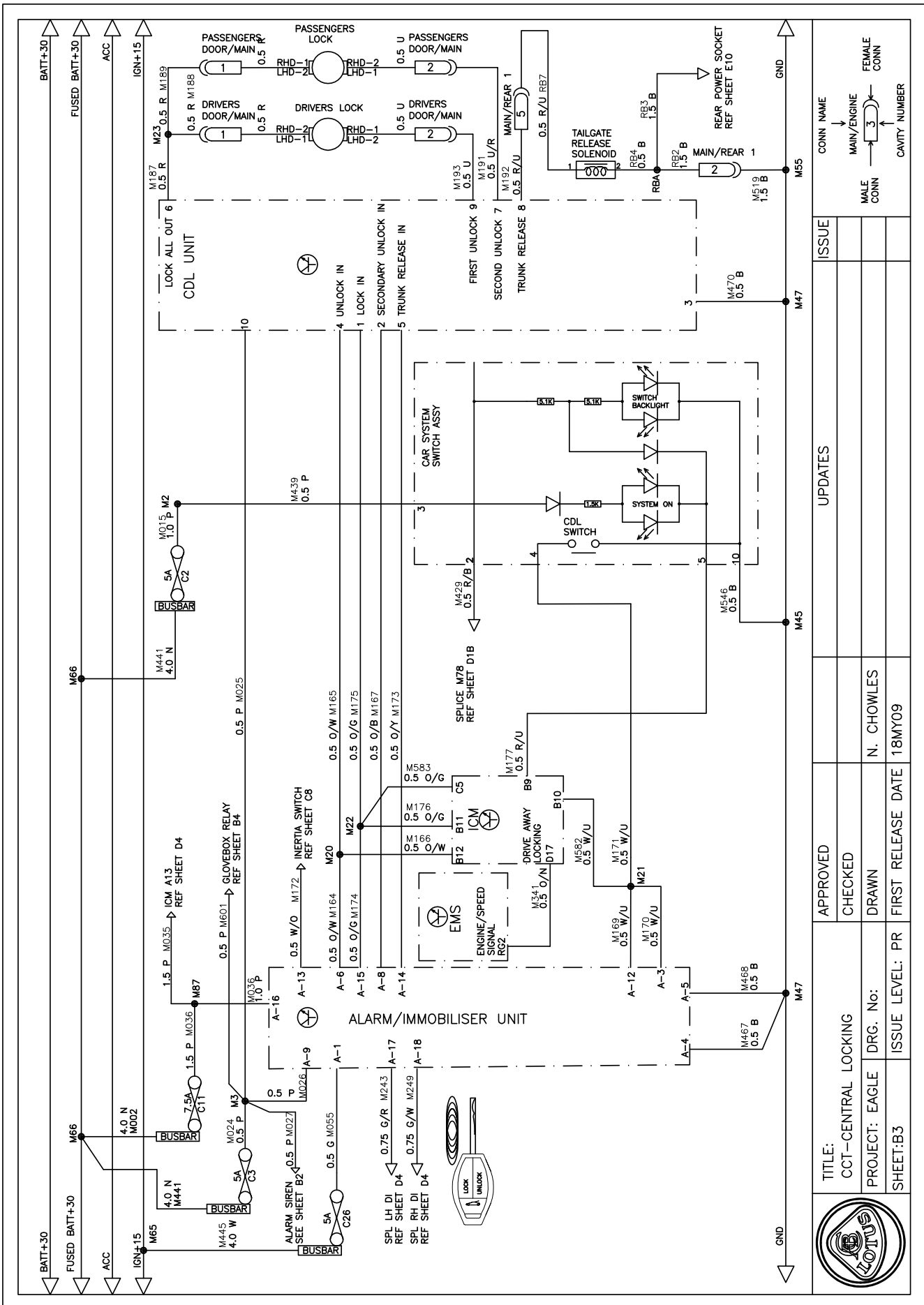

TITLE: CCT-ALARM & IMMOBILISER		APPROVED		UPDATES		CONN NAME
PROJECT: EAGLE		CHECKED				MAIN/ENGINE
DRG. No:		DRAWN				MALE CONN
ISSUE LEVEL: PR		FIRST RELEASE DATE		18MY09		3
SHEET:B2						FEMALE CONN
						CAVITY NUMBER



		TITLE: CCT-CENTRAL LOCKING PROJECT: EAGLE DRG. No: SHEET: B3		APPROVED CHECKED DRAWN N. CHOWLES FIRST RELEASE DATE 18MY09	UPDATES	ISSUE	CONN NAME MAIN/ENGINE MALE CONN FEMALE CONN CAVITY NUMBER
---	--	--	--	---	---------	-------	---

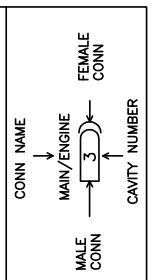
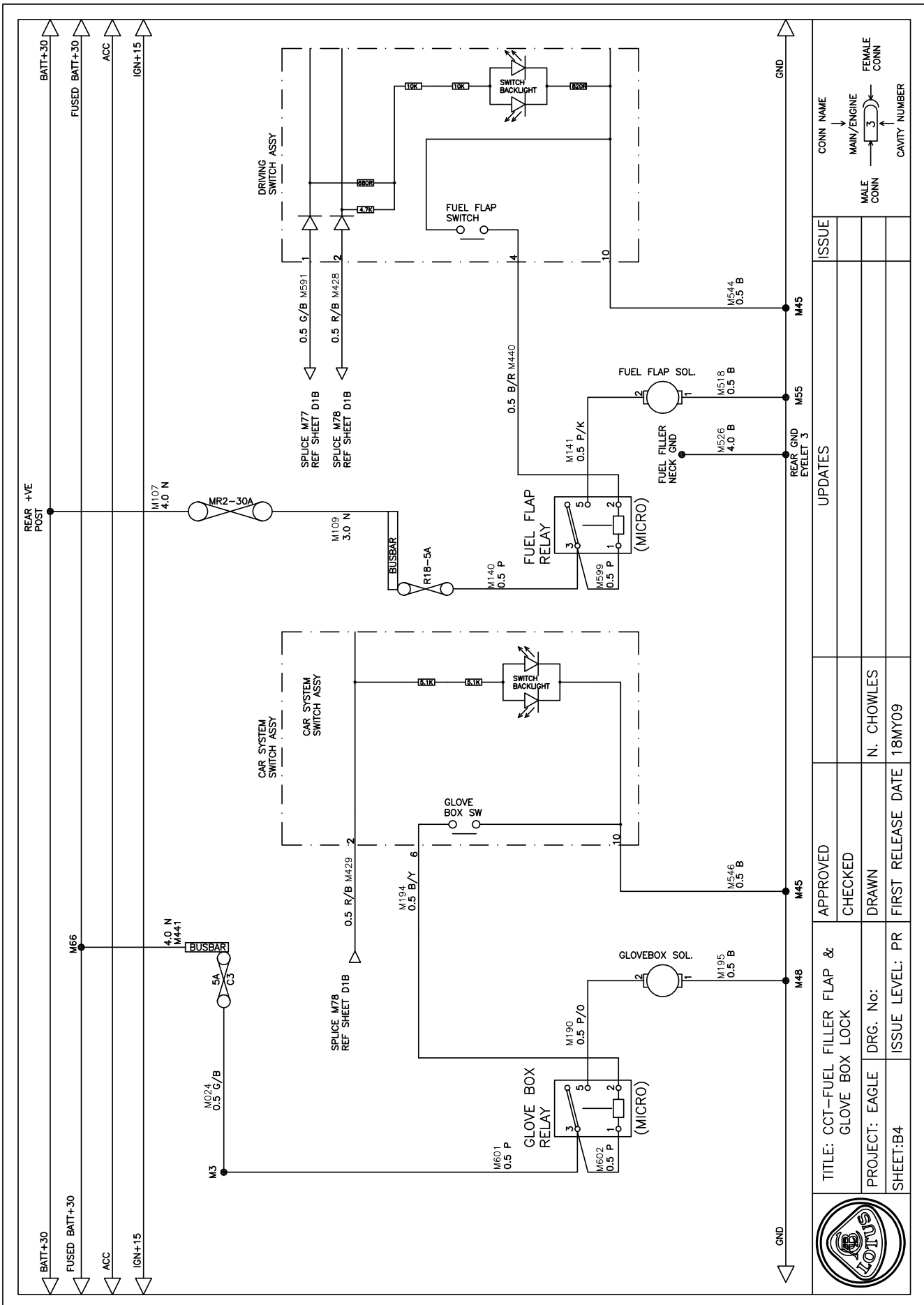

TITLE: CCT-FUEL FILLER FLAP & GLOVE BOX LOCK		ISSUE	
PROJECT: EAGLE	DRG. No:	UPDATES	
SHEET:B4	ISSUE LEVEL: PR	APPROVED	CHECKED
	FIRST RELEASE DATE 18MY09	DRAWN	N. CHOWLES



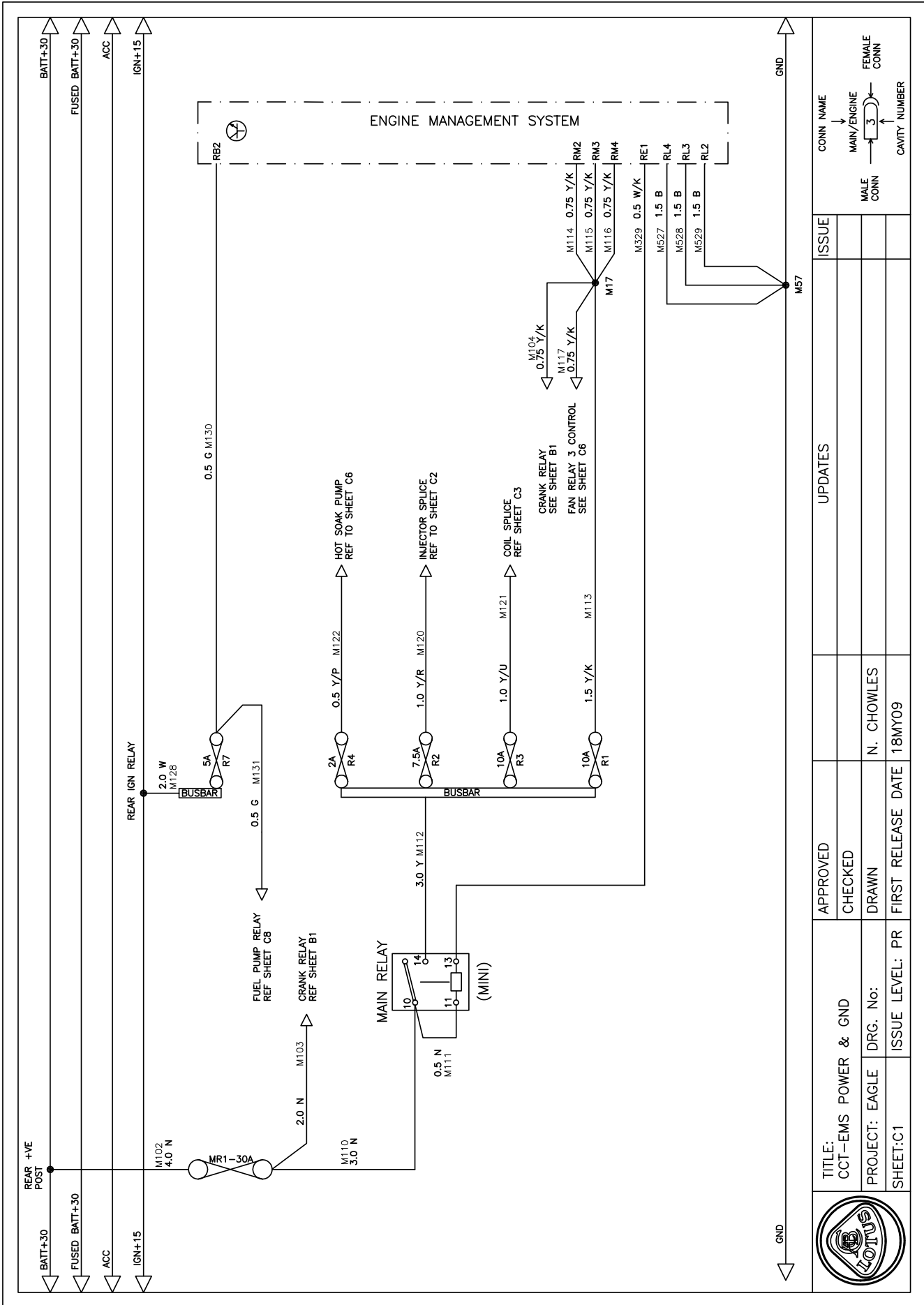

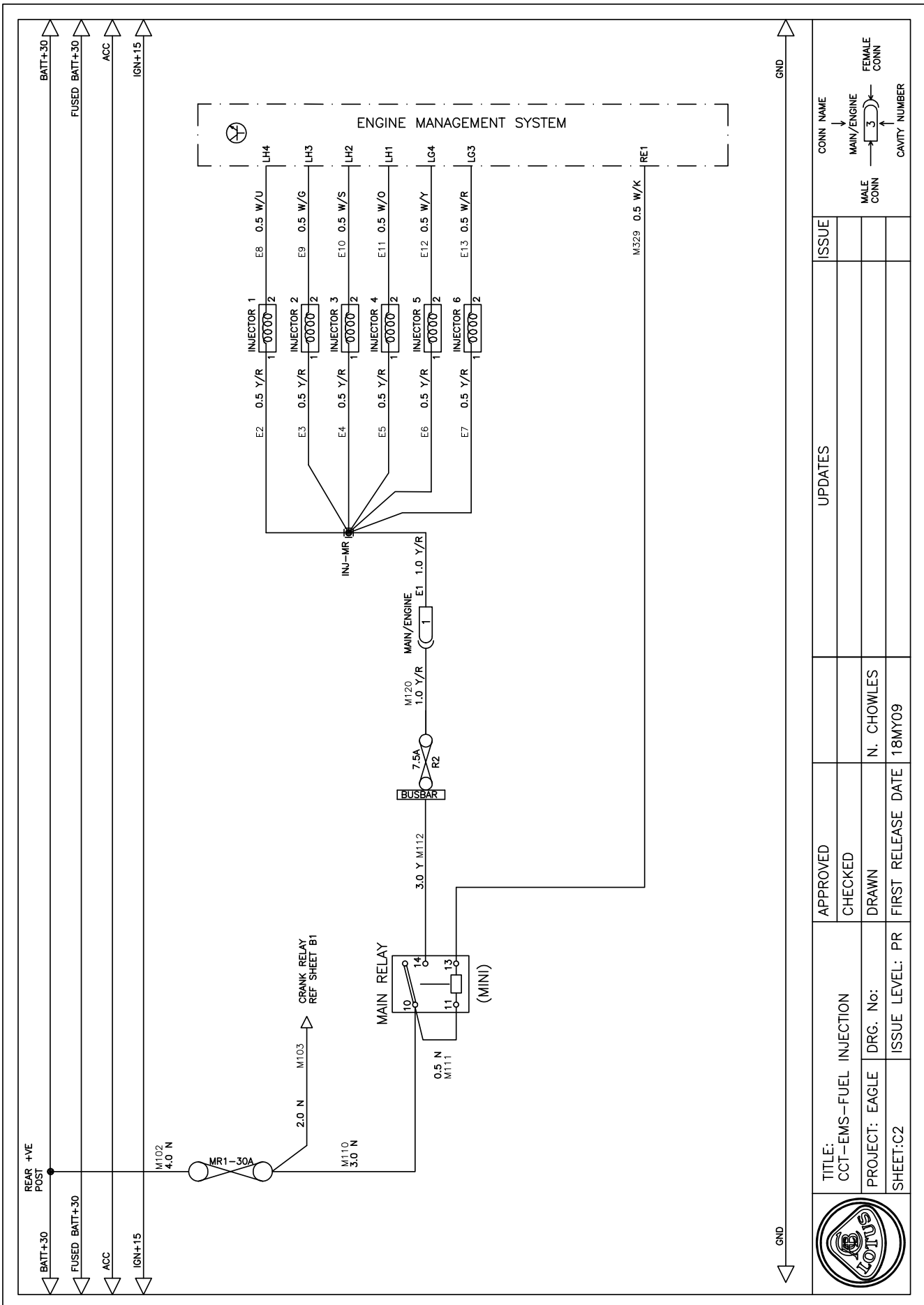



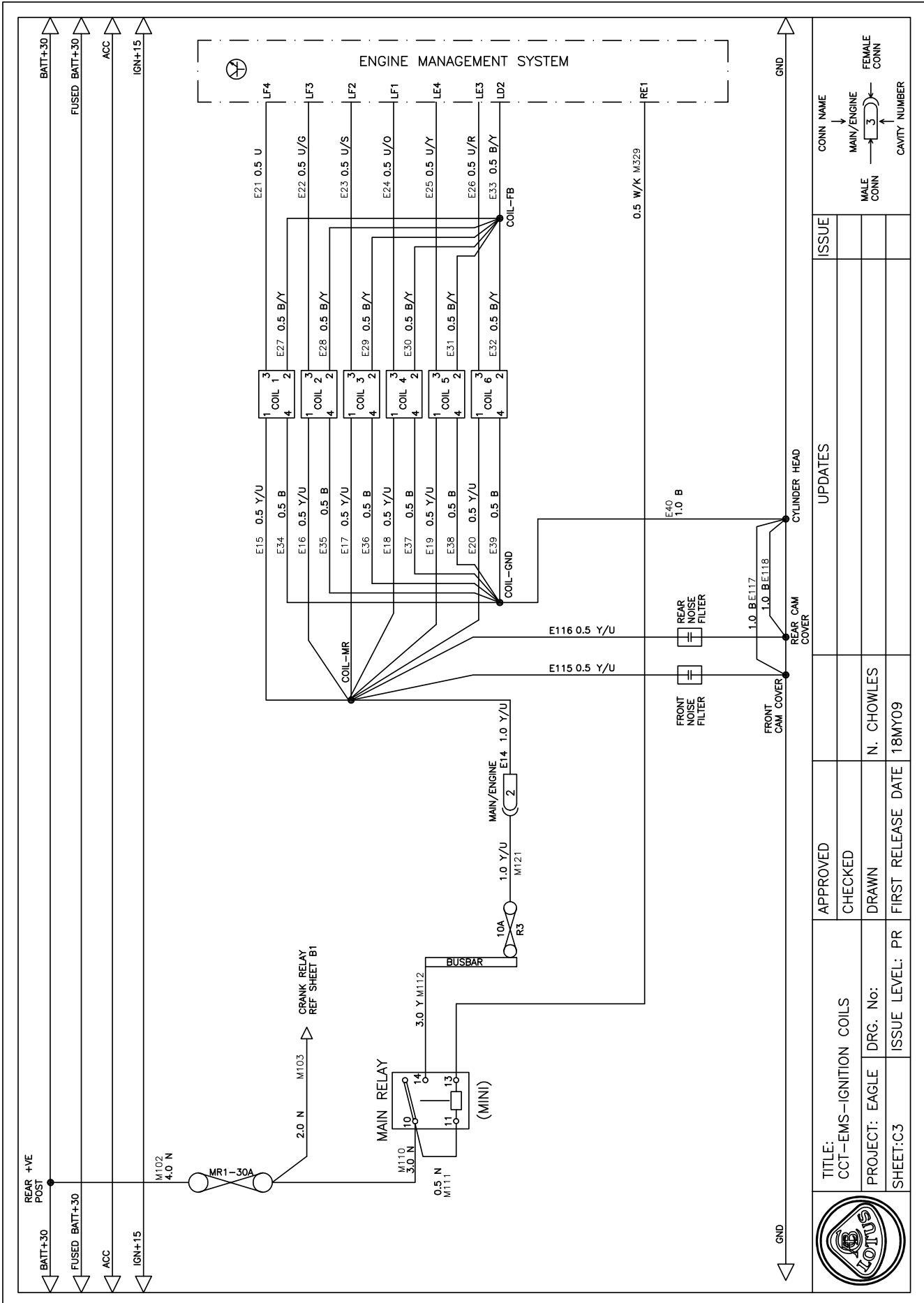

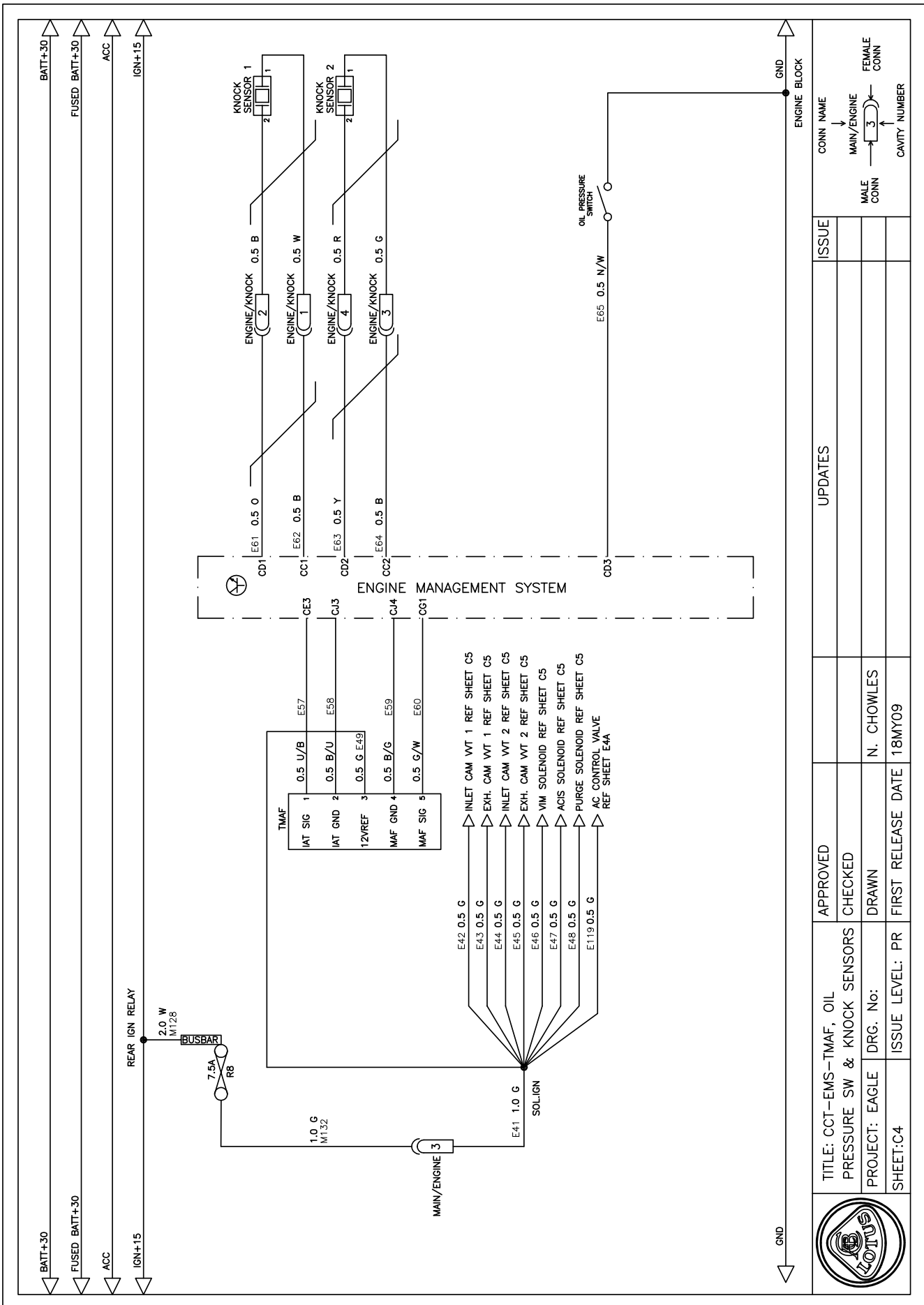

CONN NAME	MAIN/ENGINE	FEMALE CONN
	MALE CONN	
		CAVITY NUMBER

ISSUE	UPDATES

APPROVED	
CHECKED	
DRAWN	N. CHOWLES
FIRST RELEASE DATE	18MY09

TITLE: CCT-EMS-TMAF, OIL PRESSURE SW & KNOCK SENSORS	
PROJECT: EAGLE DRG. No:	
SHEET:C4	

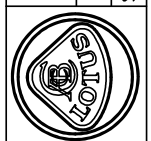

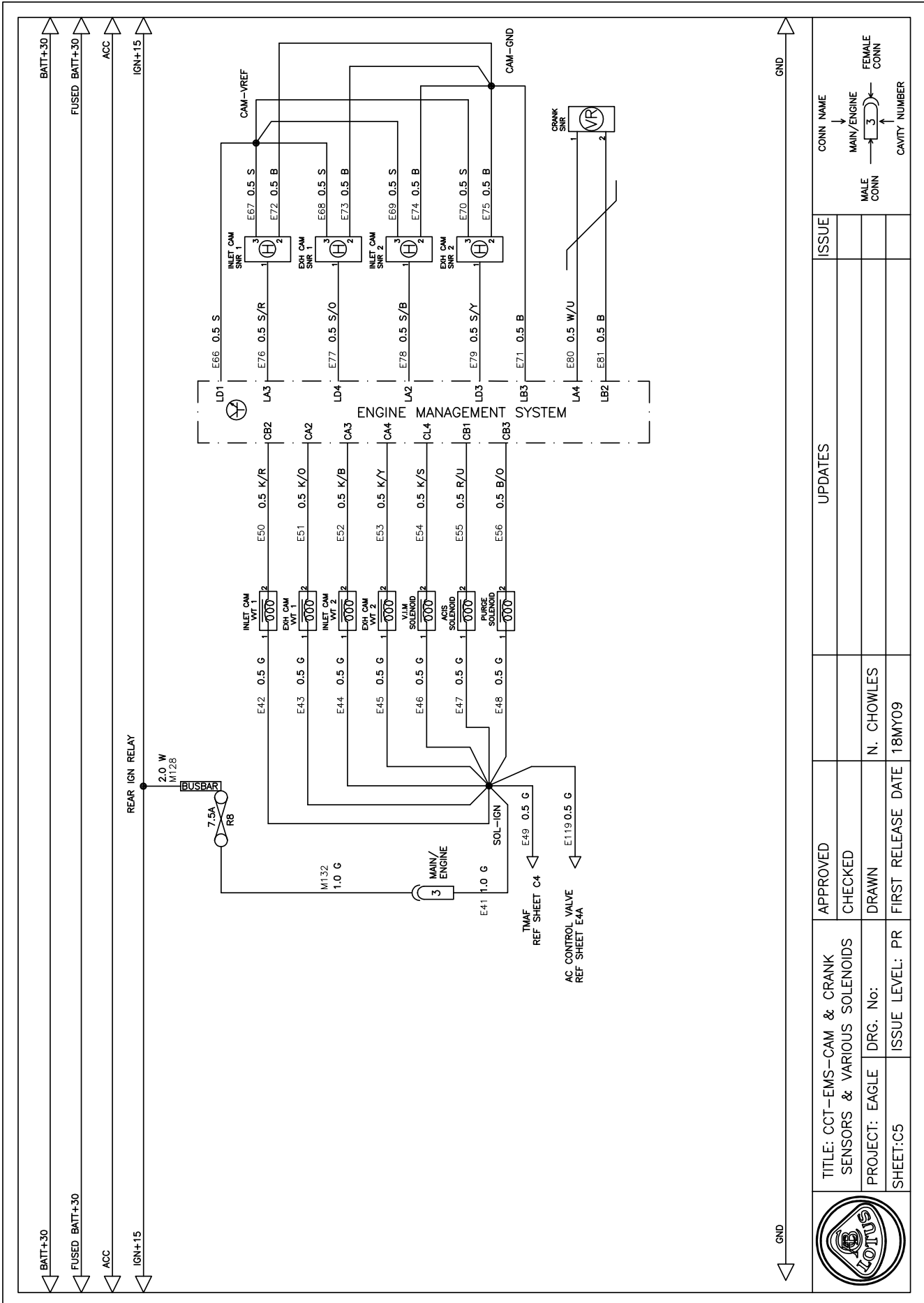

TITLE: CCT-EMS-CAM & CRANK SENSORS & VARIOUS SOLENOIDS		APPROVED	UPDATES	ISSUE
PROJECT: EAGLE	DRG. No:	CHECKED		
SHEET:C5	ISSUE LEVEL: PR	DRAWN		
	FIRST RELEASE DATE	N. CHOWLES		
	18MY09			

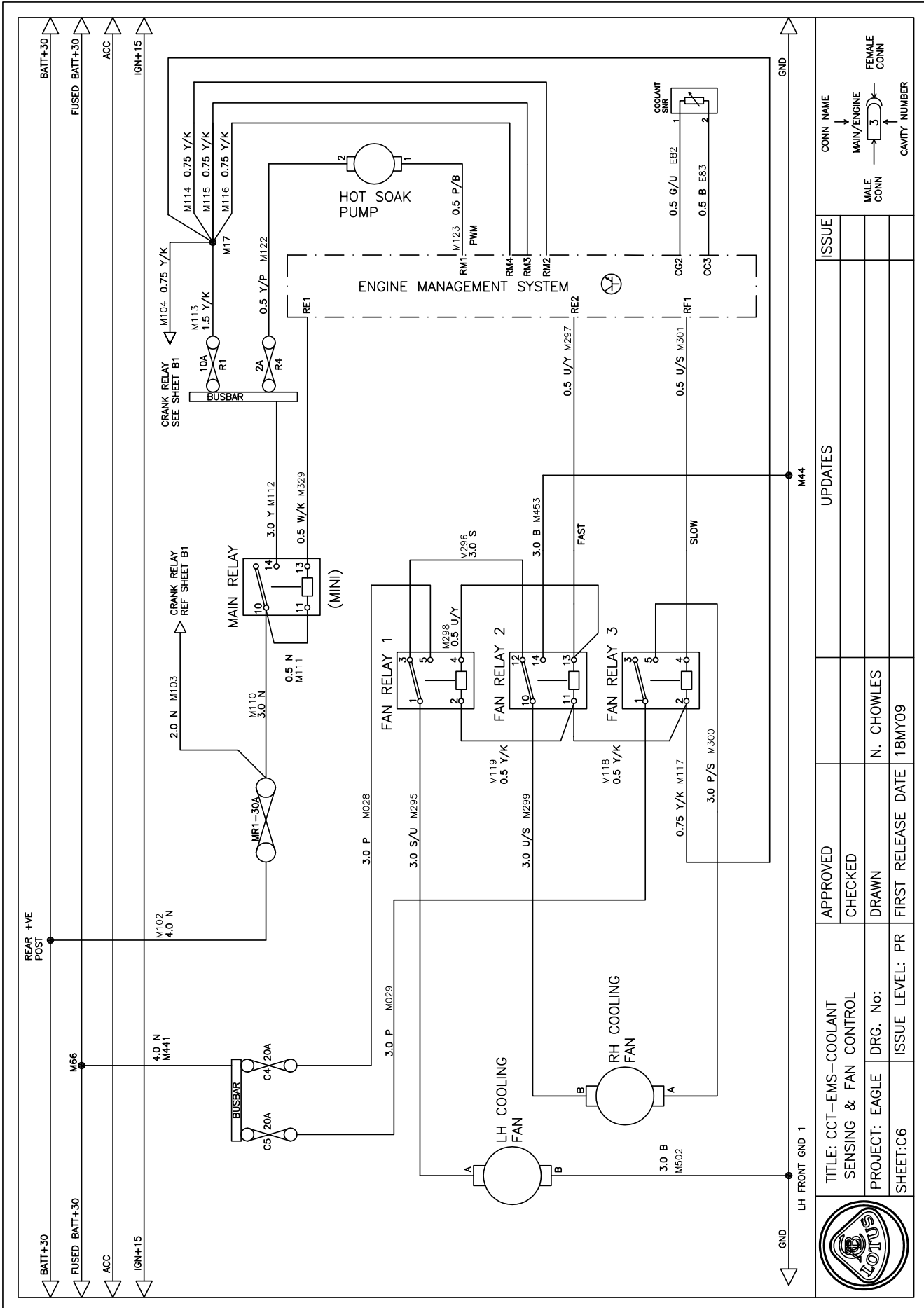

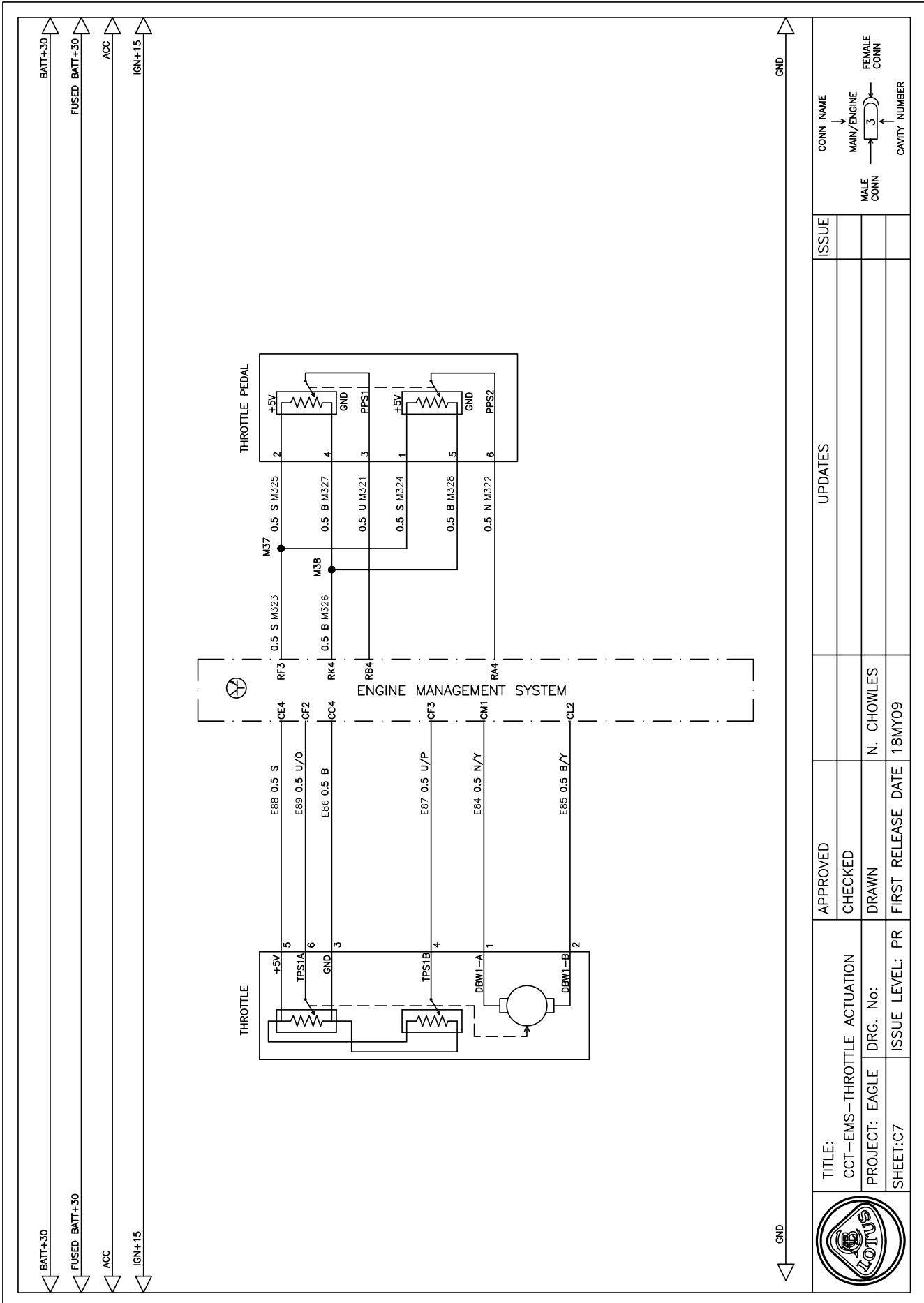

		TITLE: CCT-EMS-THROTTLE ACTUATION PROJECT: EAGLE DRG. No: SHEET:C7		APPROVED CHECKED DRAWN FIRST RELEASE DATE	UPDATES     	ISSUE     	CONN NAME MAIN/ENGINE MALE CONN → 3 ← FEMALE CONN CAVITY NUMBER
		N. CHOWLES					
		18MY09					

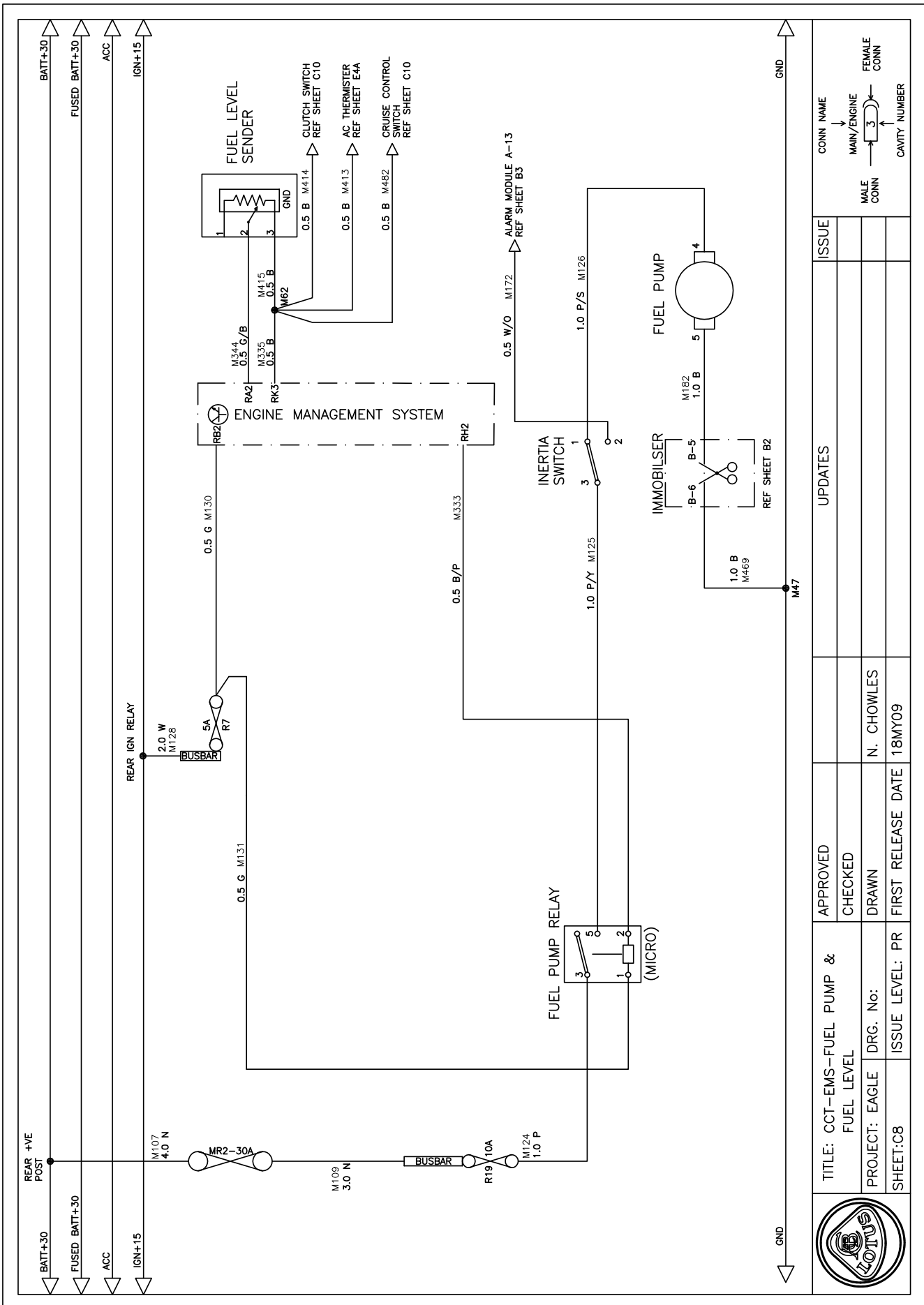

		TITLE: CCT-EMS-FUEL PUMP & FUEL LEVEL		APPROVED	UPDATES		ISSUE
PROJECT: EAGLE		DRG. No:	N. CHOWLES	CHECKED			CONN NAME
SHEET:C8		ISSUE LEVEL: PR	FIRST RELEASE DATE 18MY09	DRAWN			MAIN/ENGINE
							MALE CONN
							3
							FEMALE CONN
							CAVITY NUMBER

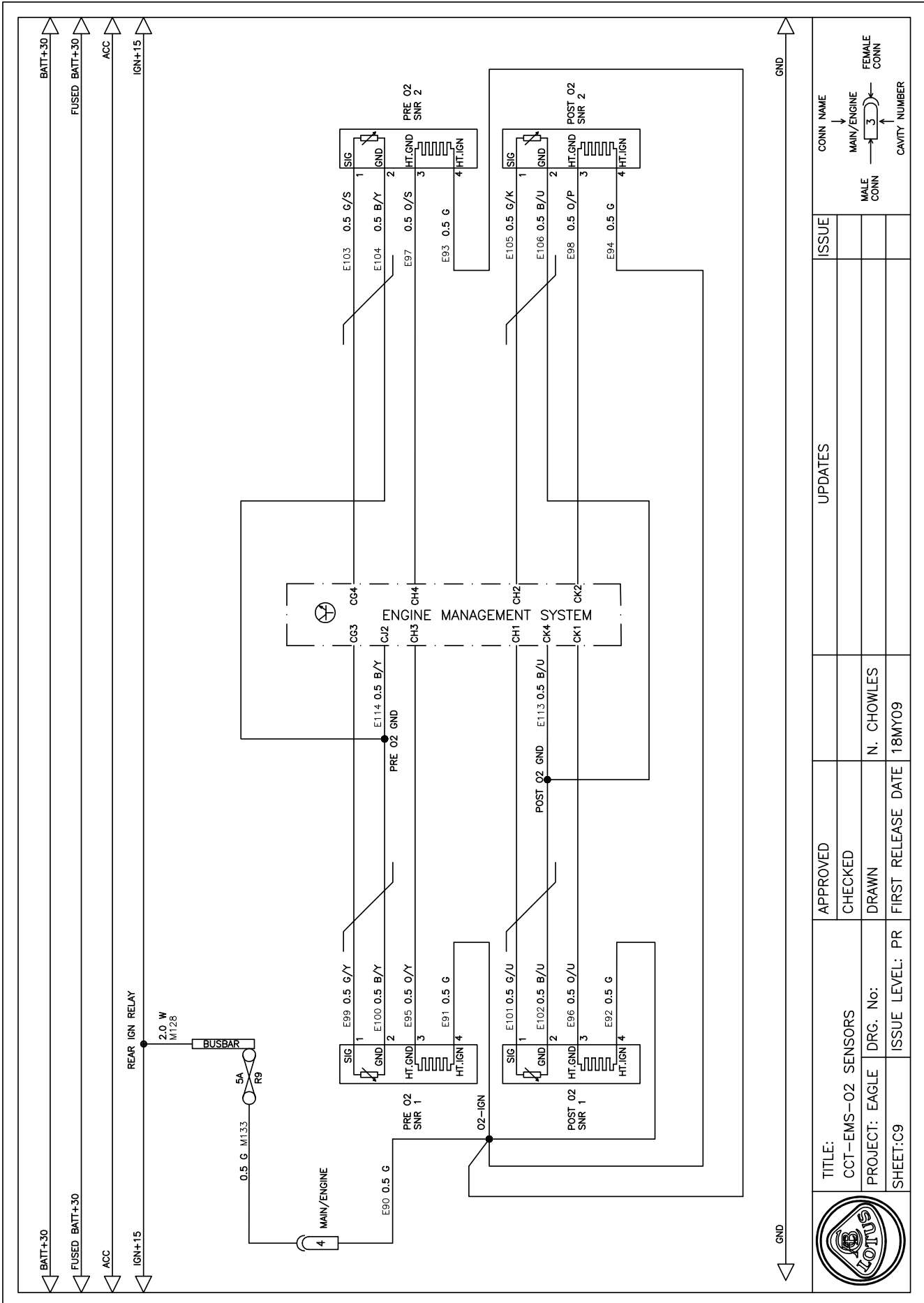

	TITLE: CCT-EMS-02 SENSORS	APPROVED CHECKED	ISSUE	
	PROJECT: EAGLE DRG. No: SHEET:C9	DRAWN N. CHOWLES	UPDATES	
	ISSUE LEVEL: PR	FIRST RELEASE DATE 18MY09	CONN NAME MAIN/ENGINE	

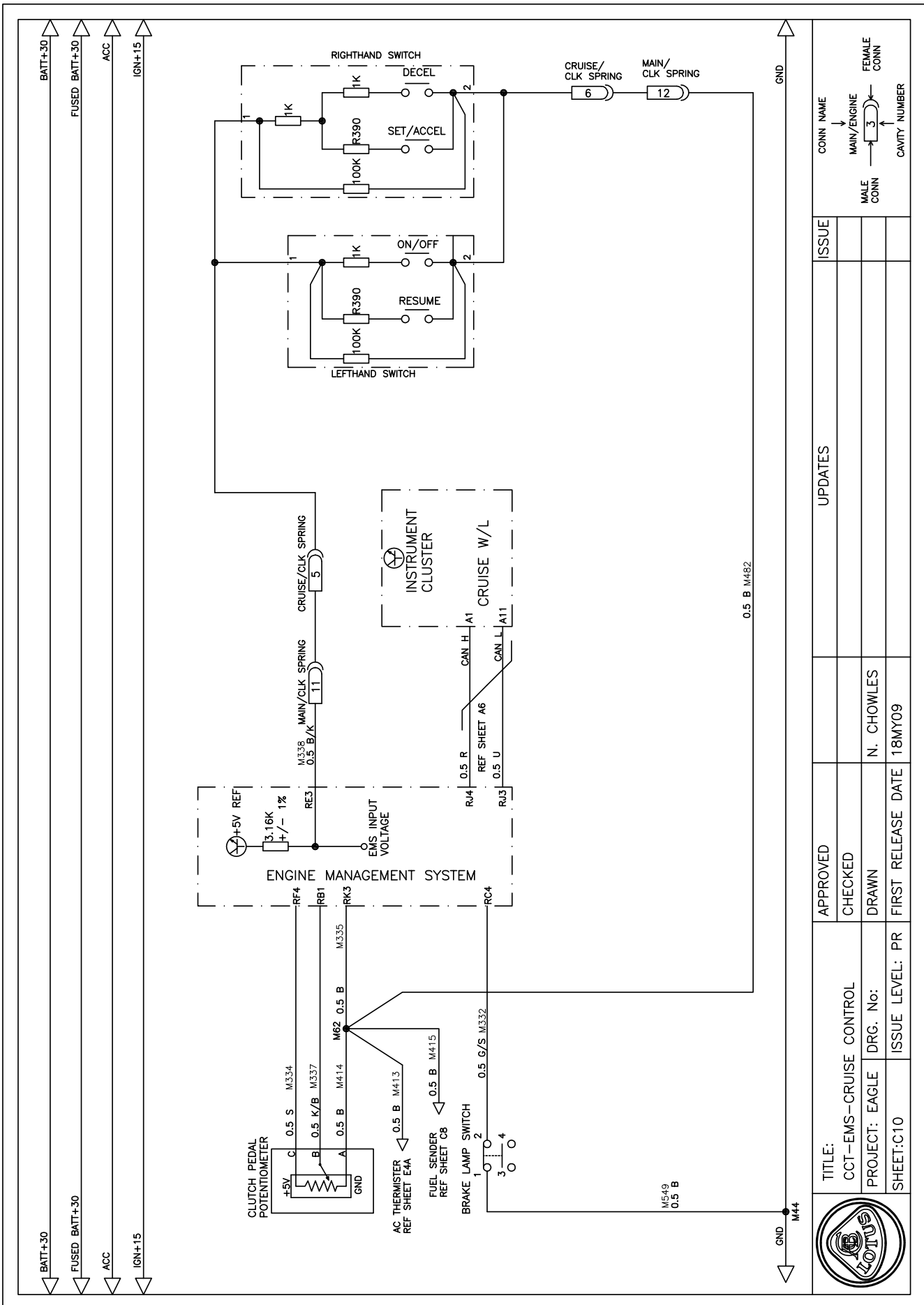



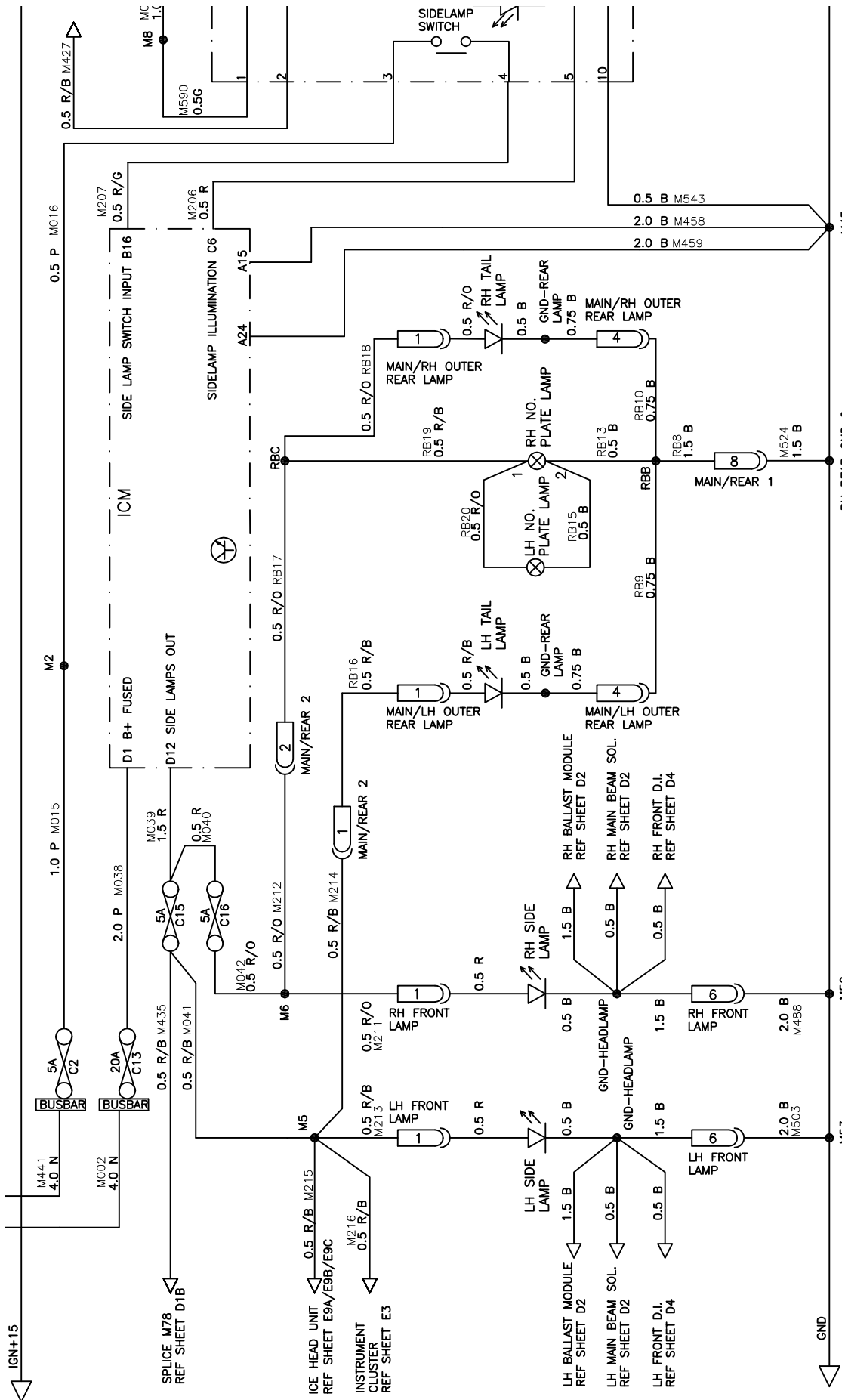

TITLE: CCT-SIDE LAMPS		APPROVED	ISSUE
PROJECT: EAGLE		CHECKED	
SHEET:D1A		DRAWN	
DRG. No:		N. CHOWLES	
ISSUE LEVEL: PR		FIRST RELEASE DATE	18MY09
MAL CON			

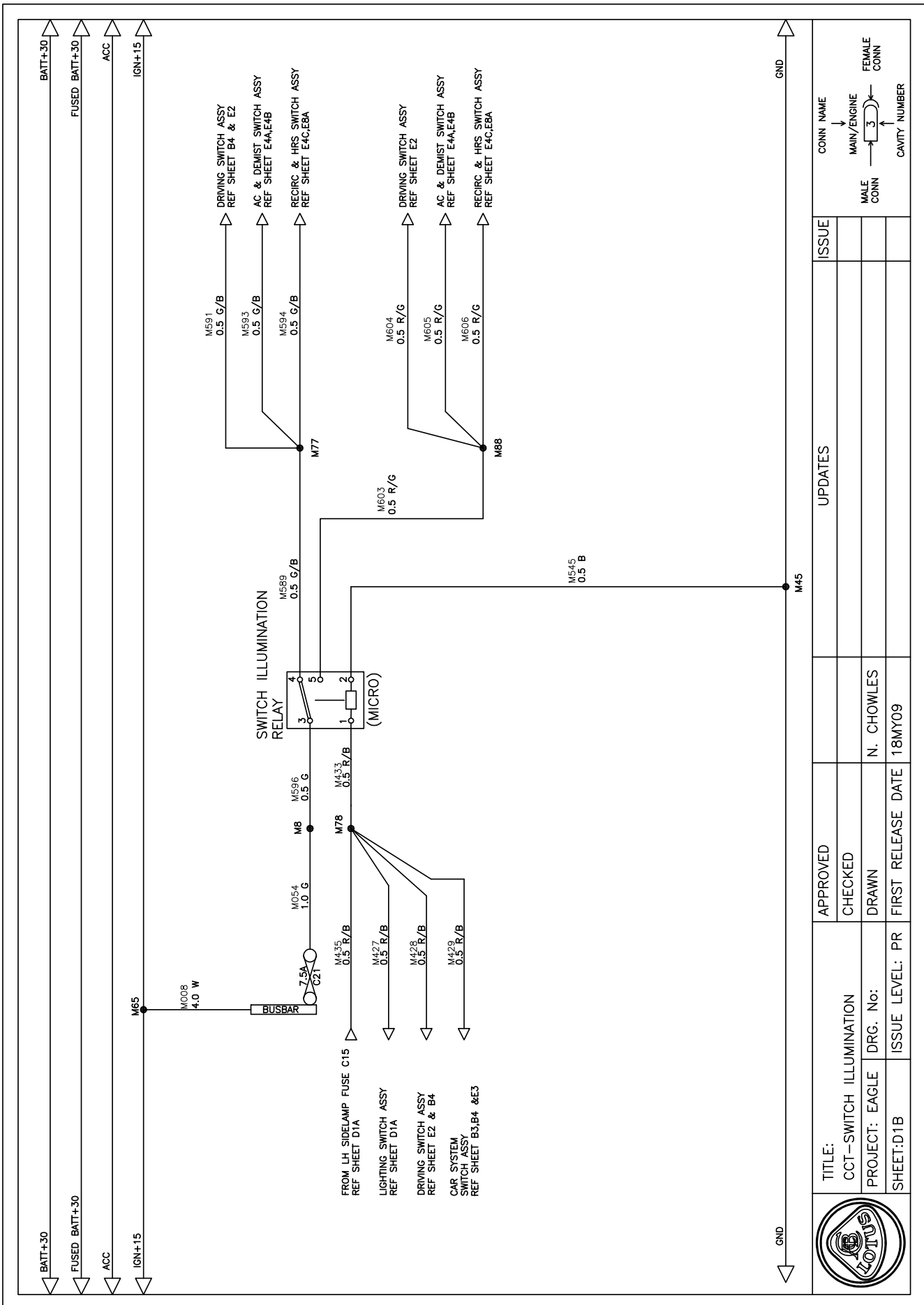

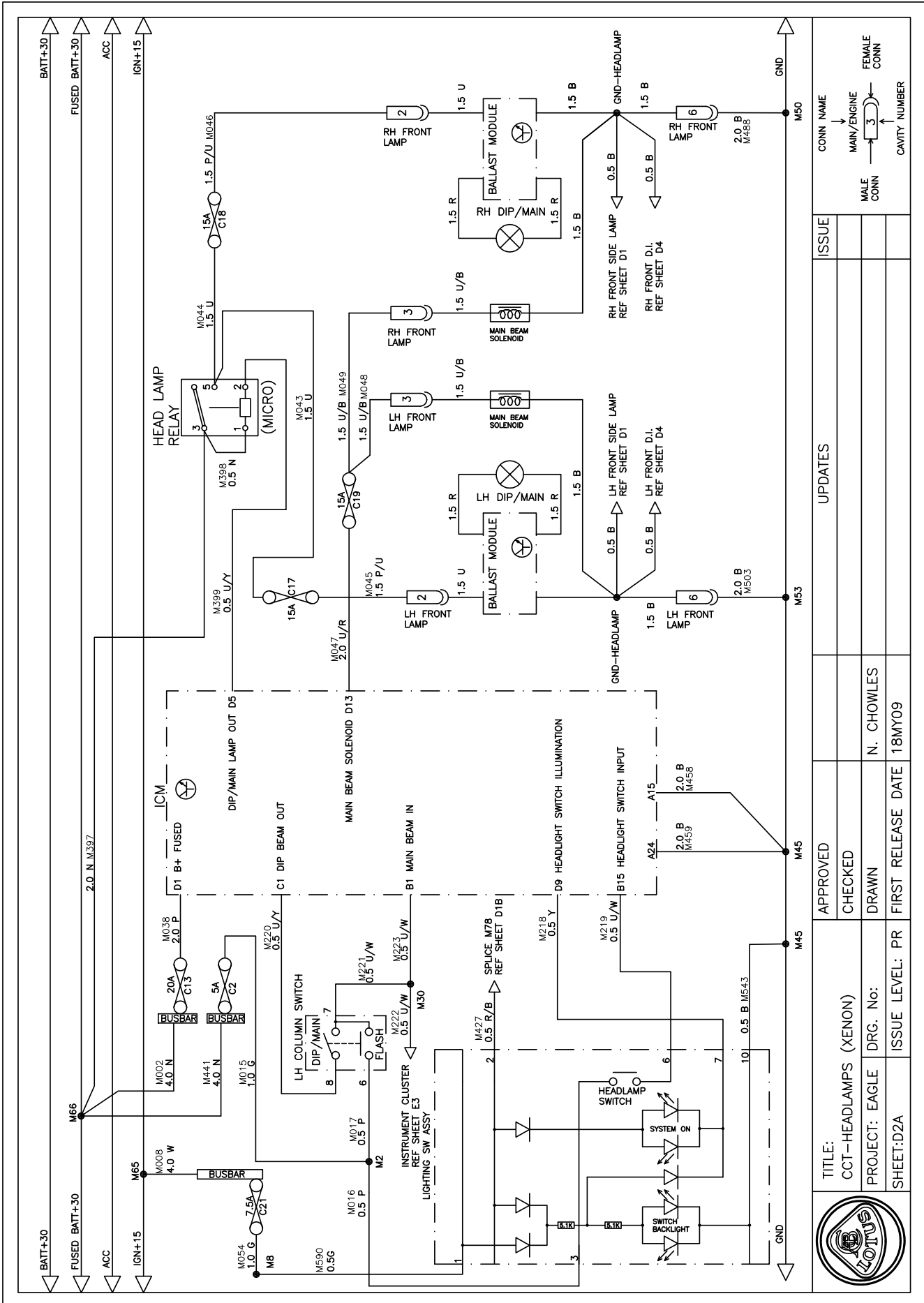

		<b>TITLE:</b> CCT-HEADLAMPS (XENON)		<b>APPROVED</b> 		<b>ISSUE</b> 	
<b>PROJECT:</b> EAGLE		<b>DRG. No.:</b> N. CHOWLES		<b>CHECKED</b> 		<b>UPDATES</b> 	
<b>SHEET:DZA</b>		<b>ISSUE LEVEL:</b> PR		<b>FIRST RELEASE DATE:</b> 18MY09		<b>CONN NAME</b> MAIN/ENGINE MALE CONN → 3 → FEMALE CONN CAVITY NUMBER	

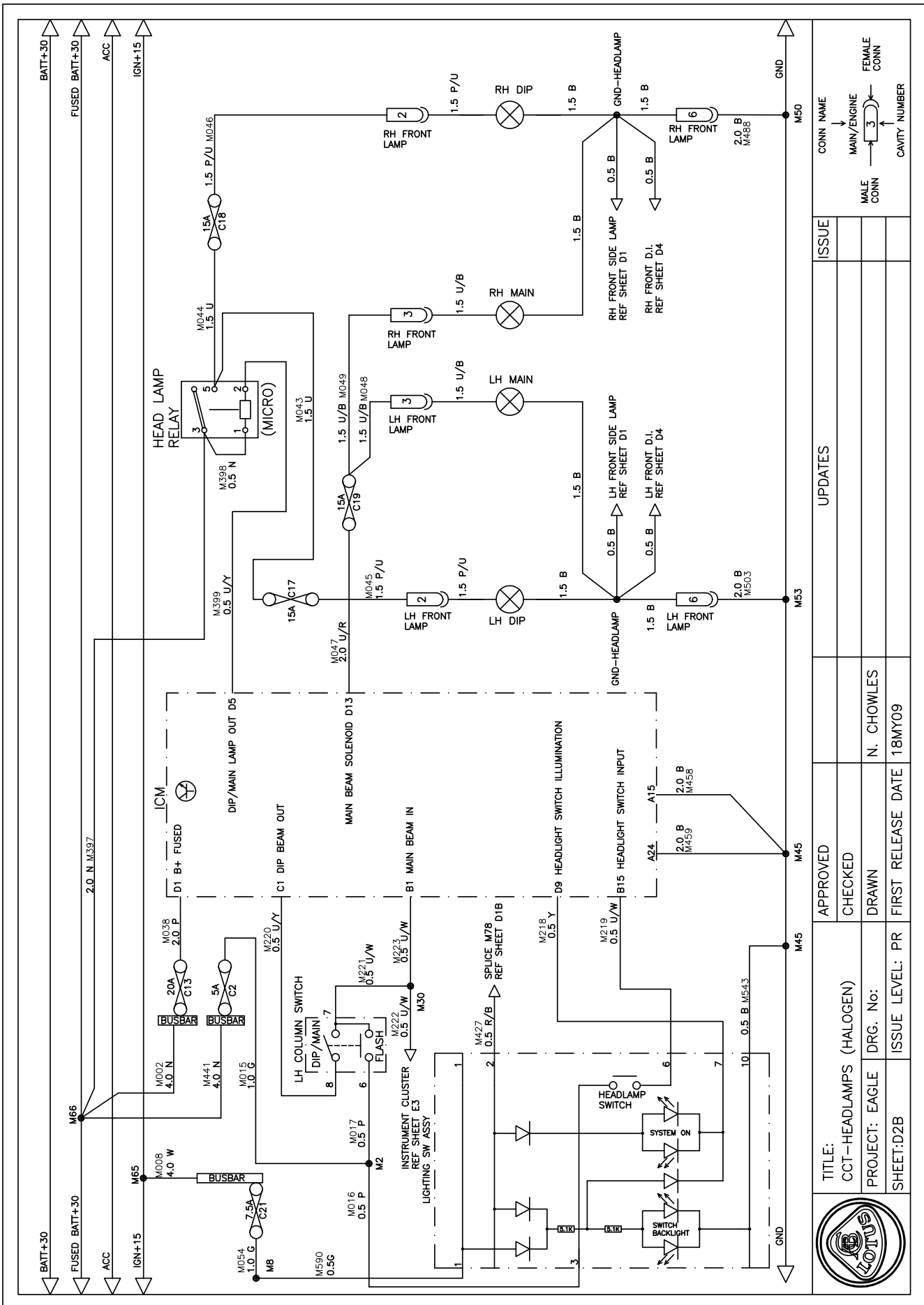

		<b>TITLE:</b> CCT-HEADLAMPS (HALOGEN)		<b>APPROVED</b> 		<b>UPDATES</b>		<b>CONN NAME</b> MAIN/ENGINE MALE CONN → 3 → FEMALE CONN CAVITY NUMBER	
<b>PROJECT:</b> EAGLE		<b>DRG. No:</b> N. CHOWLES		<b>CHECKED</b>					
<b>SHEET:</b> D2B		<b>ISSUE LEVEL:</b> PR		<b>DRAWN</b>					
		<b>FIRST RELEASE DATE:</b> 18MY09							

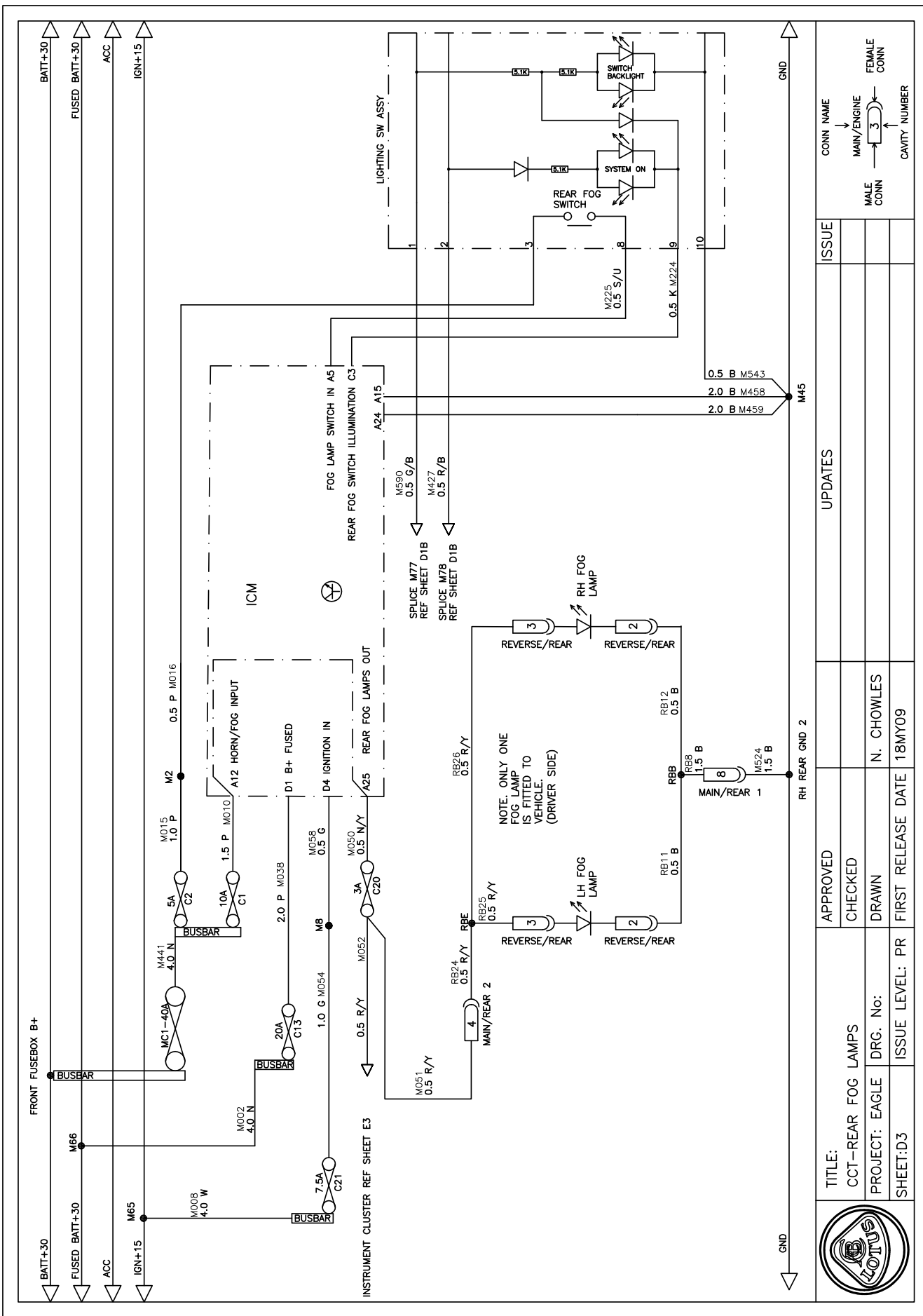

TITLE: CCT-REAR FOG LAMPS	APPROVED	ISSUE	CONN NAME MAIN/ENGINE
PROJECT: EAGLE DRG. No:	CHECKED	UPDATES	MALE CONN
SHEET: D3	DRAWN		3 CAVITY NUMBER
ISSUE LEVEL: PR	FIRST RELEASE DATE 18MY09		FEMALE CONN



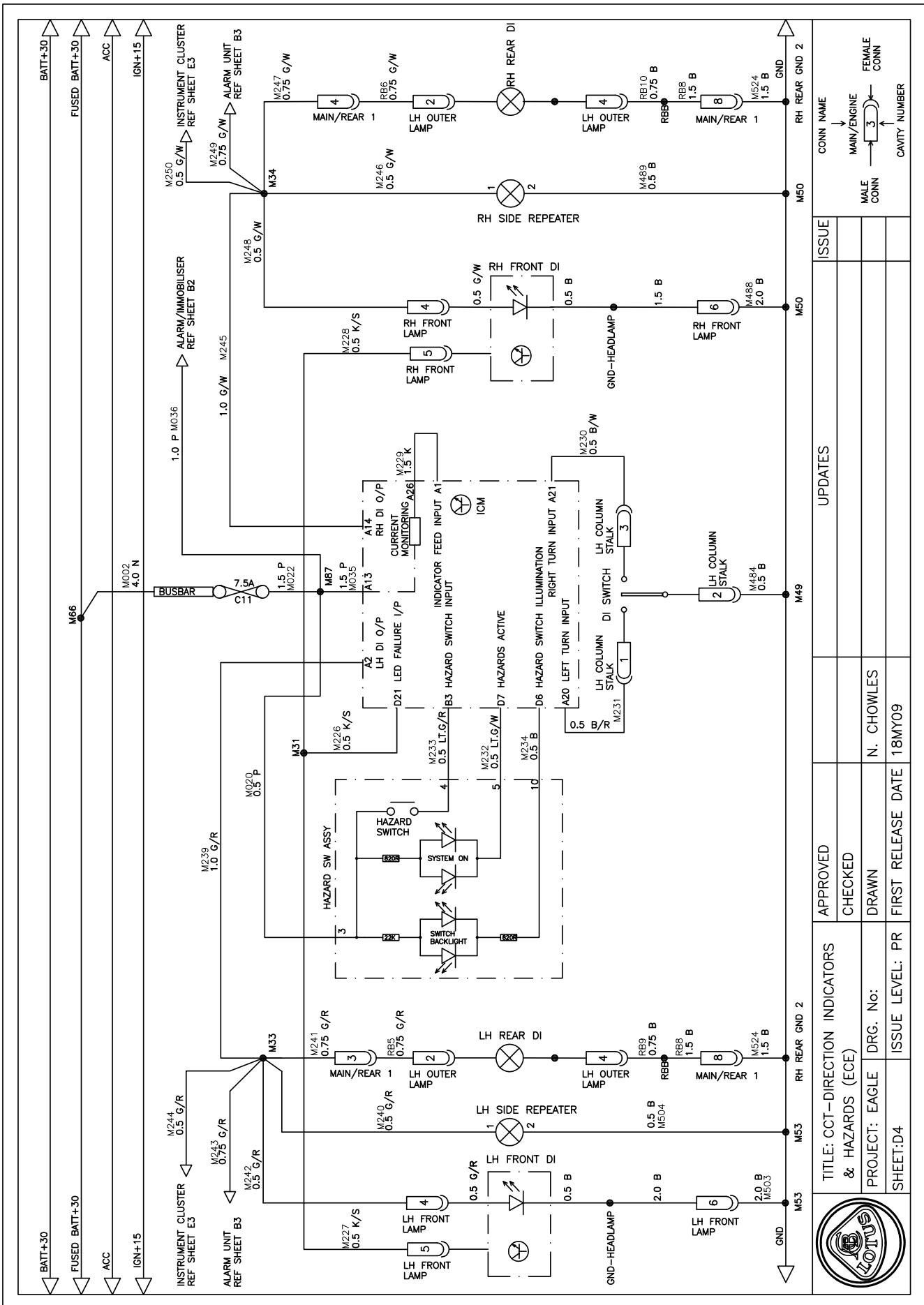

		TITLE: CCT-DIRECTION INDICATORS & HAZARDS (ECE)		APPROVED		UPDATES		ISSUE	
PROJECT: EAGLE		DRG. No:		CHECKED		N. CHOWLES		MALE CONN	
SHEET:D4		ISSUE LEVEL: PR		DRAWN		FIRST RELEASE DATE		FEMALE CONN	
18MY09		18MY09		18MY09		18MY09		CAVITY NUMBER	

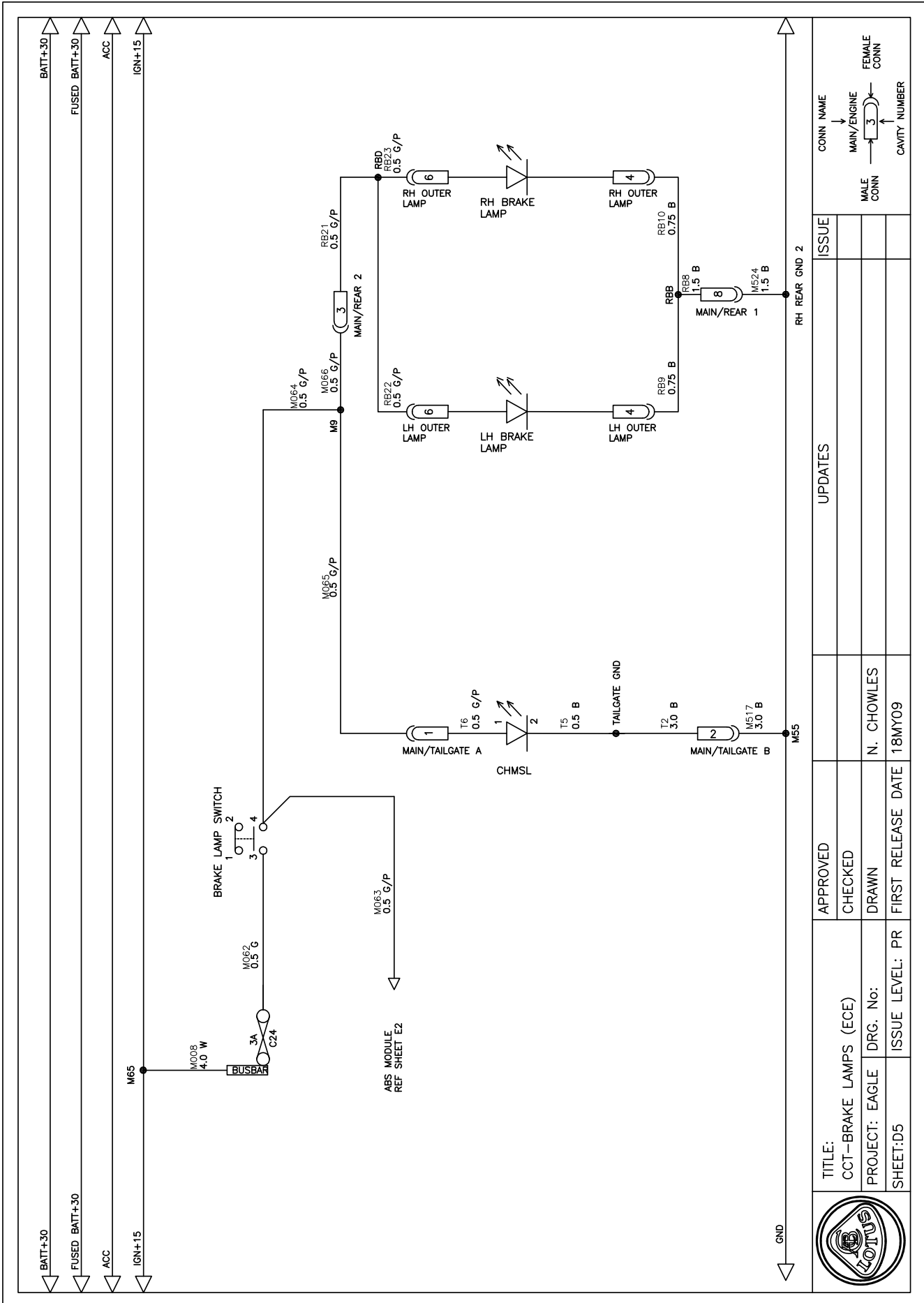

<b>TITLE:</b> CCT-BRAKE LAMPS (ECE) <b>PROJECT:</b> EAGLE <b>SHEET:</b> D5	<b>APPROVED</b> [Signature]	<b>ISSUE</b>		
	<b>CHECKED</b> [Signature]	<b>UPDATES</b>		
	<b>DRAWN</b> N. CHOWLES	<b>CONN NAME</b> MAIN/ENGINE	<b>MALE CONN</b> 3	<b>FEMALE CONN</b> 3
	<b>FIRST RELEASE DATE</b> 18MY09	<b>ISSUE LEVEL:</b> PR	<b>CAVITY NUMBER</b>	<b>CONNECTION DIAGRAM</b>

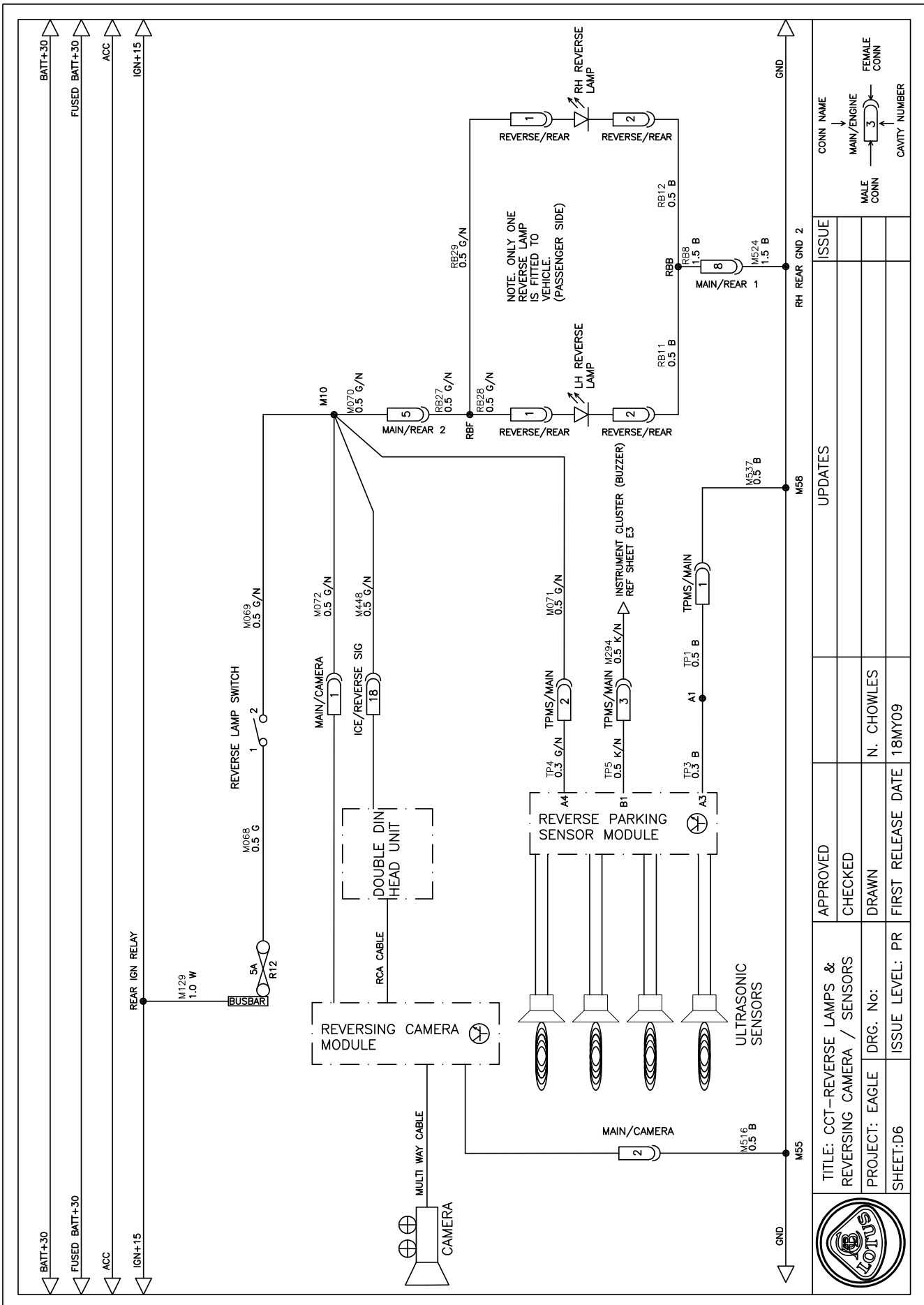



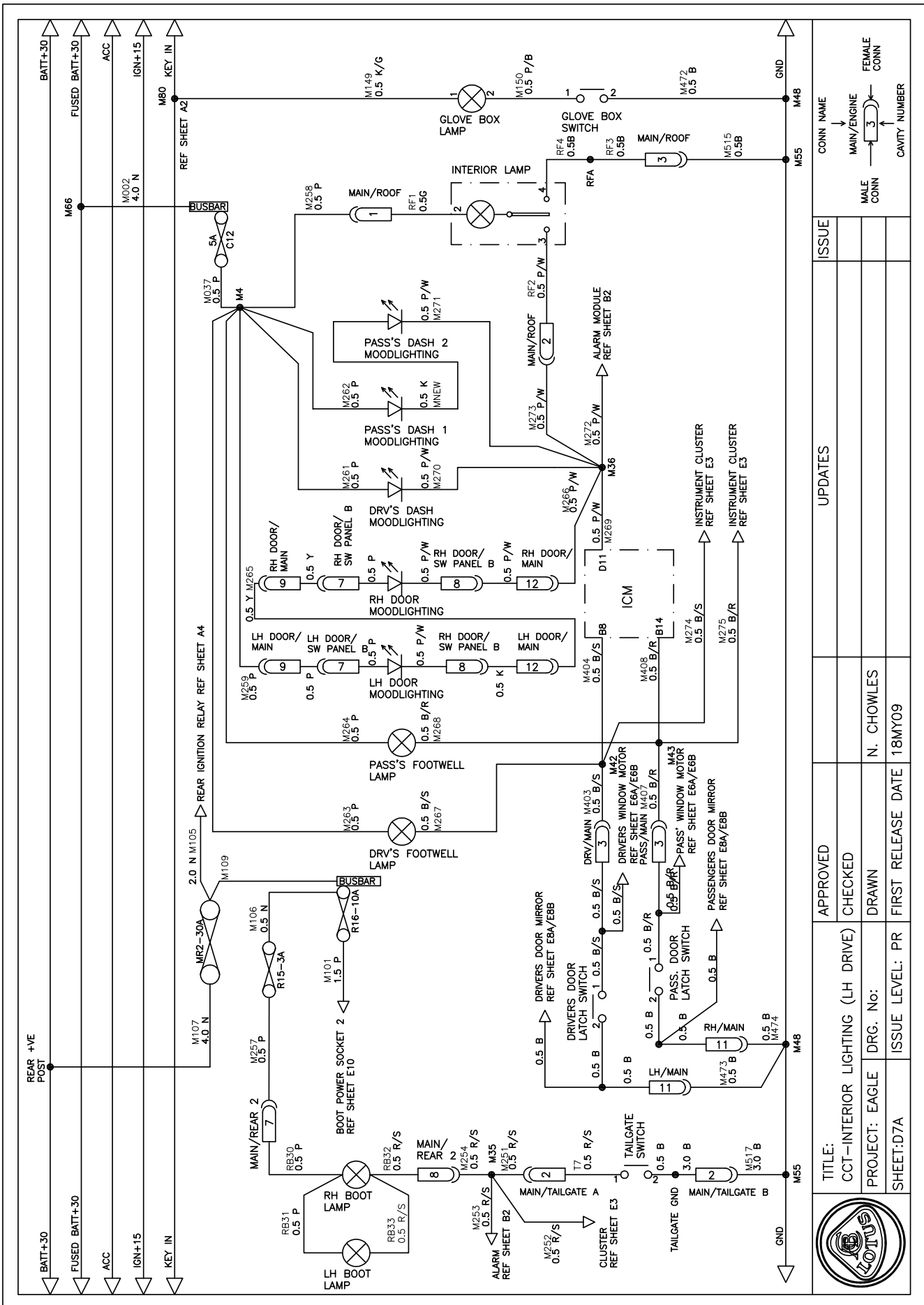

TITLE: CCT-INTERIOR LIGHTING (LH DRIVE)		APPROVED	ISSUE
PROJECT: EAGLE	DRG. No:	CHECKED	
SHEET:D7A	ISSUE LEVEL: PR	DRAWN	
	FIRST RELEASE DATE	N. CHOWLES	
	18MY09		
UPDATES			
CONN NAME		MALE CONN	FEMALE CONN
		MAIN/ENGINE	3
			CAVITY NUMBER

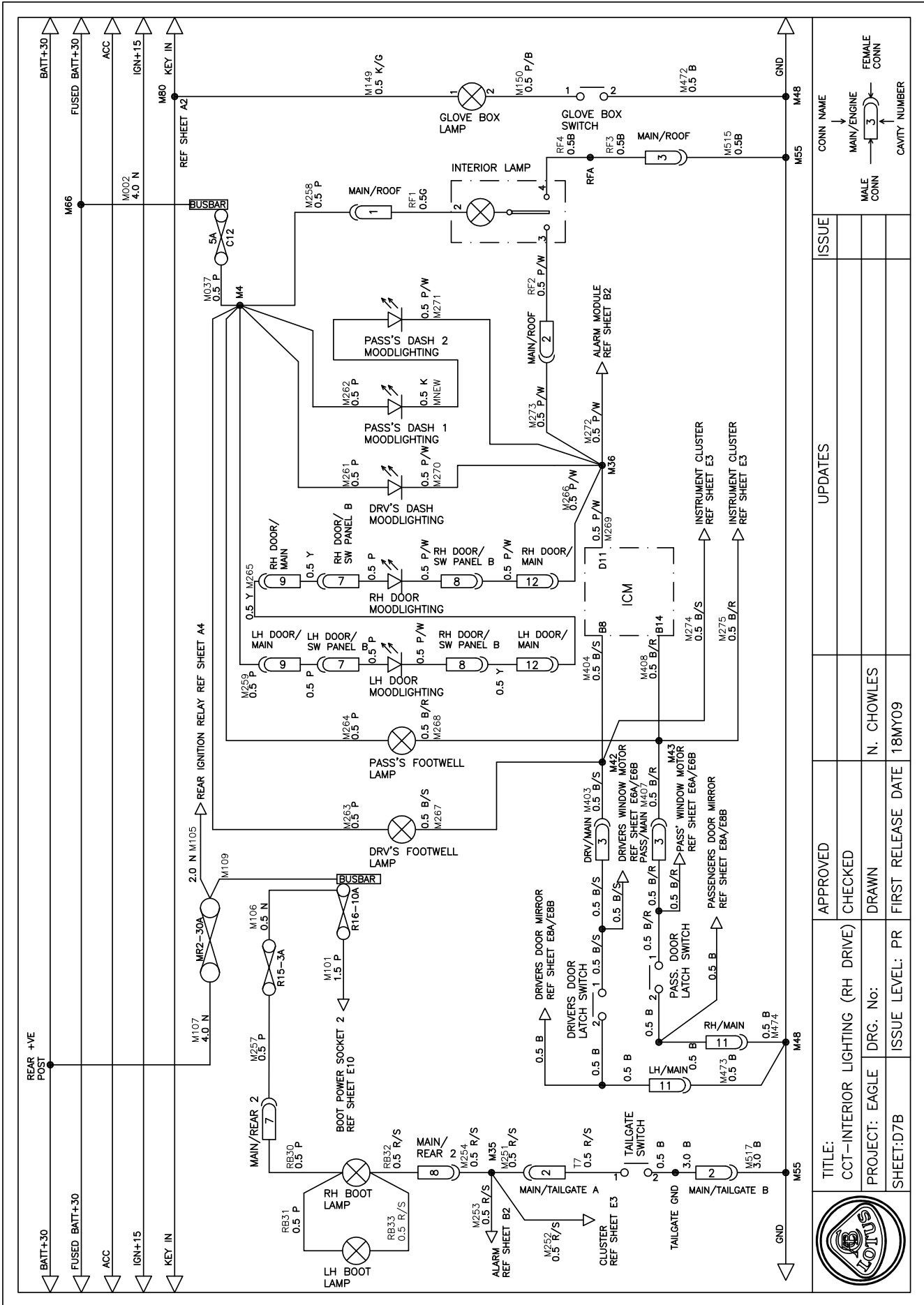

		<b>TITLE:</b> CCT-INTERIOR LIGHTING (RH DRIVE)		<b>APPROVED</b> 		<b>ISSUE</b> 	
<b>PROJECT:</b> EAGLE		<b>DRG. No:</b> N. CHOWLES		<b>CHECKED</b> 			
<b>SHEET:</b> D7B		<b>ISSUE LEVEL:</b> PR		<b>FIRST RELEASE DATE:</b> 18MY09			
						<b>UPDATES</b> 	

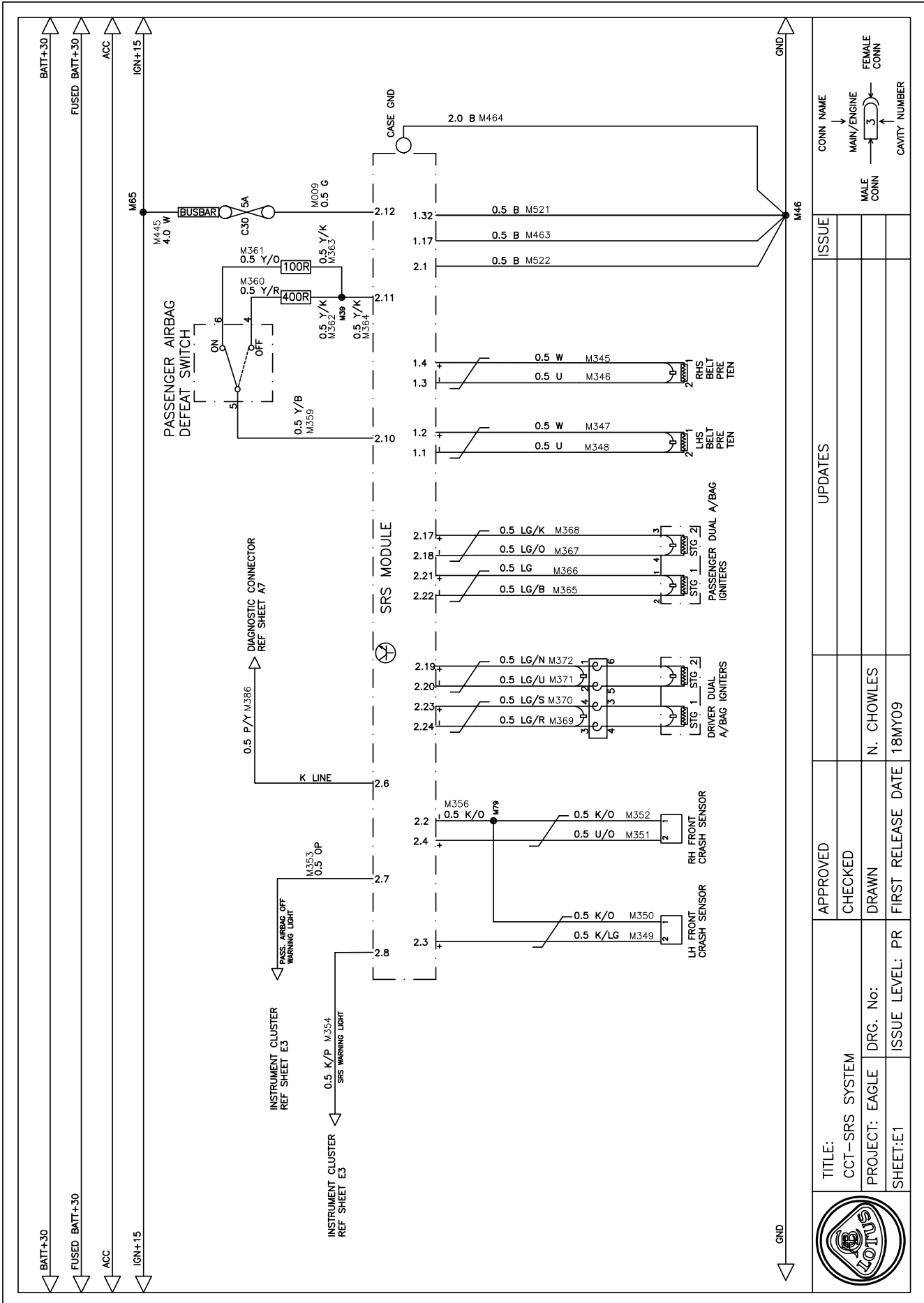

TITLE: CCT-SRS SYSTEM		APPROVED	
PROJECT: EAGLE		CHECKED	
DRG. No:		DRAWN	
SHEET:E1		FIRST RELEASE DATE	
ISSUE LEVEL: PR		18MY09	
N. CHOWLES		UPDATES	
CONN NAME		ISSUE	
MAIN/ENGINE			
MALE CONN			
FEMALE CONN			
CAVITY NUMBER			

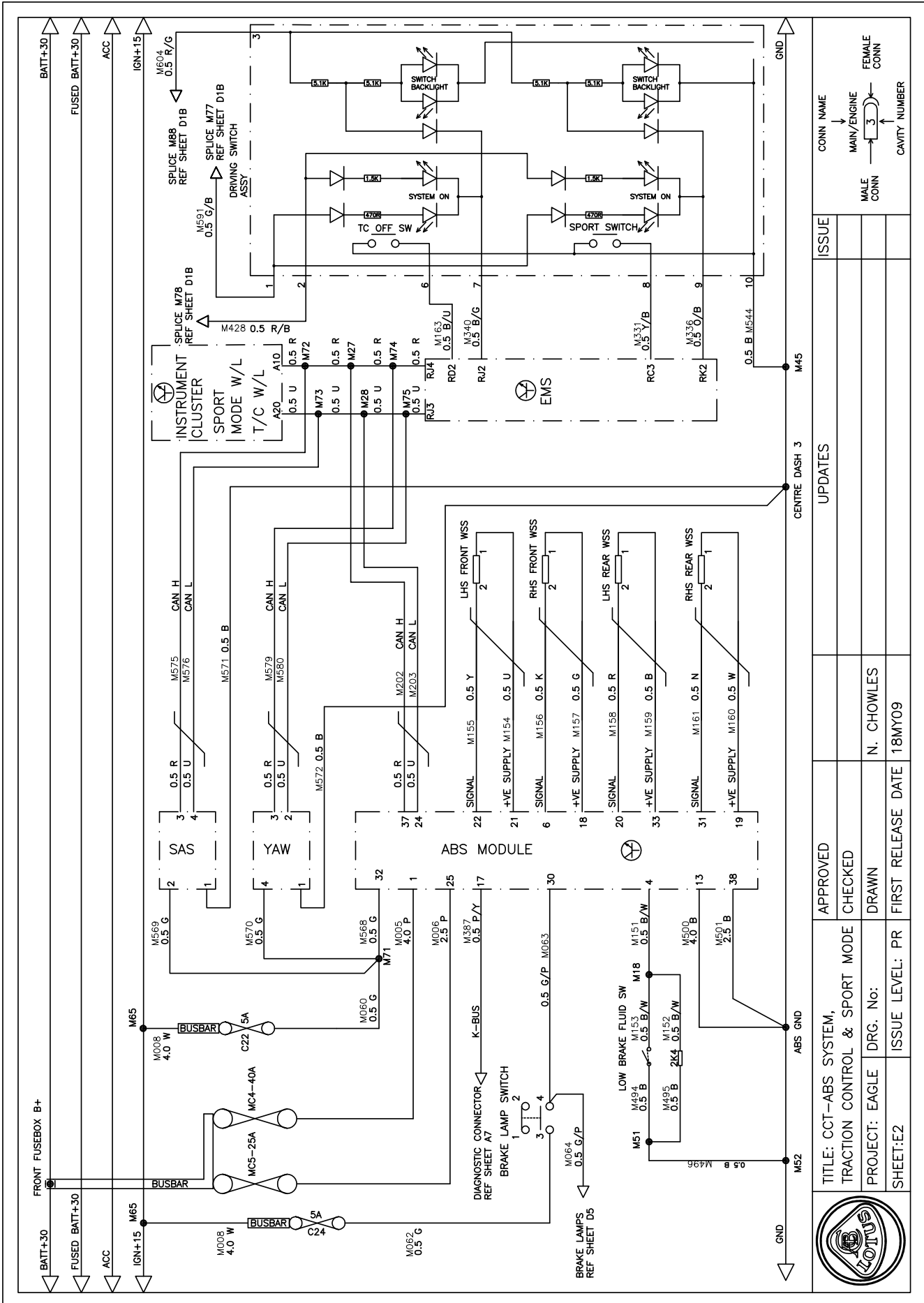

		<b>TITLE:</b> CCT-ABS SYSTEM, TRACTION CONTROL & SPORT MODE <b>PROJECT:</b> EAGLE DRG. No: <b>SHEET:</b> E2		<b>ISSUE</b>		<b>CONN NAME</b> MAIN/ENGINE MALE CONN → 3 → FEMALE CONN CAVITY NUMBER	
<b>APPROVED</b>				<b>UPDATES</b>			
<b>CHECKED</b>				N. CHOWLES			
<b>DRAWN</b>				FIRST RELEASE DATE 18MY09			

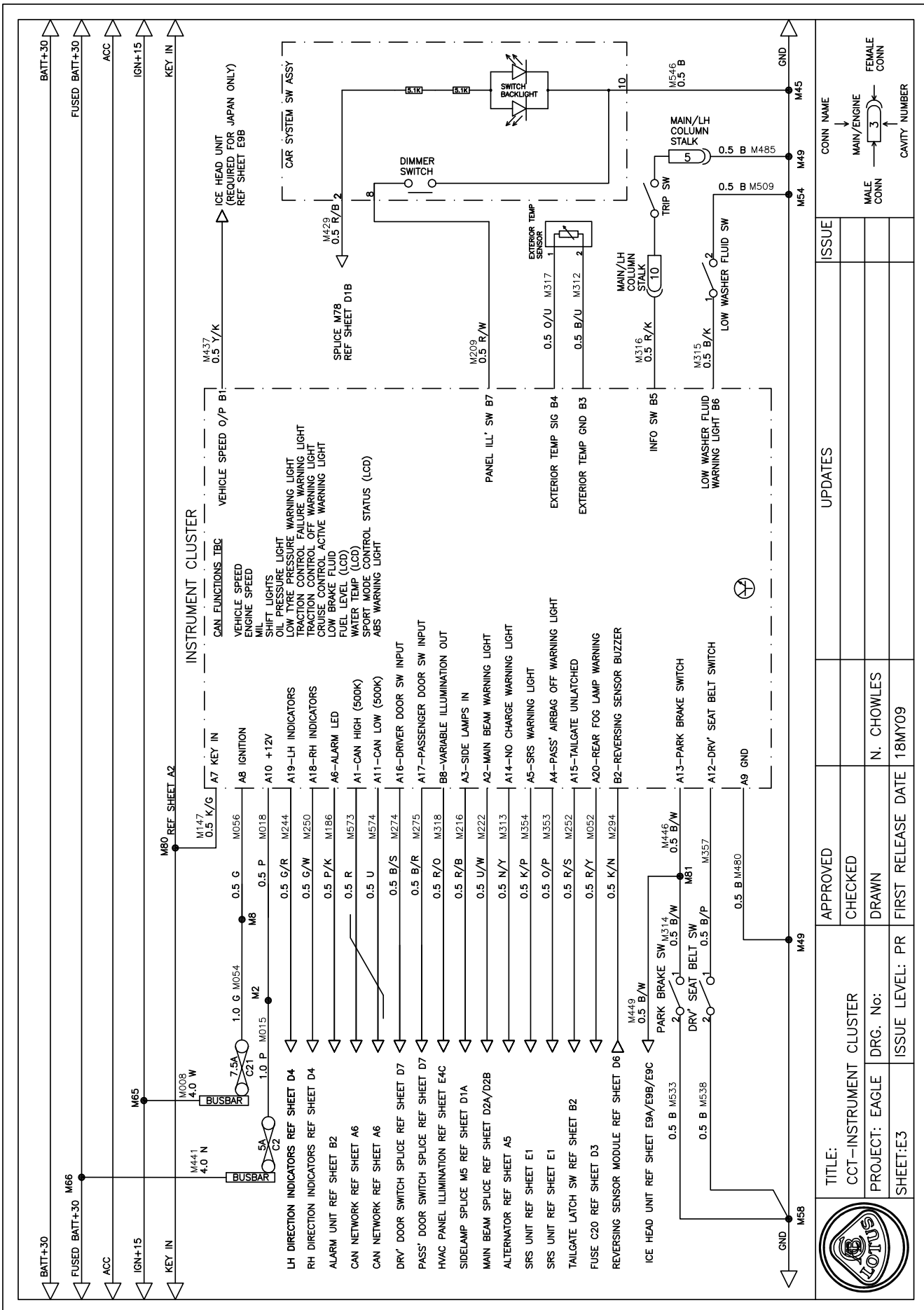

TITLE: CCT-INSTRUMENT CLUSTER		APPROVED	ISSUE
PROJECT: EAGLE DRG. No: N. CHOWLES		CHECKED	
SHEET:E3		DRAWN	
ISSUE LEVEL: PR		FIRST RELEASE DATE	
18MY09			
		CONN NAME	
		MAIN/ENGINE	
		MALE CONN	
		FEMALE CONN	
		CAVITY NUMBER	

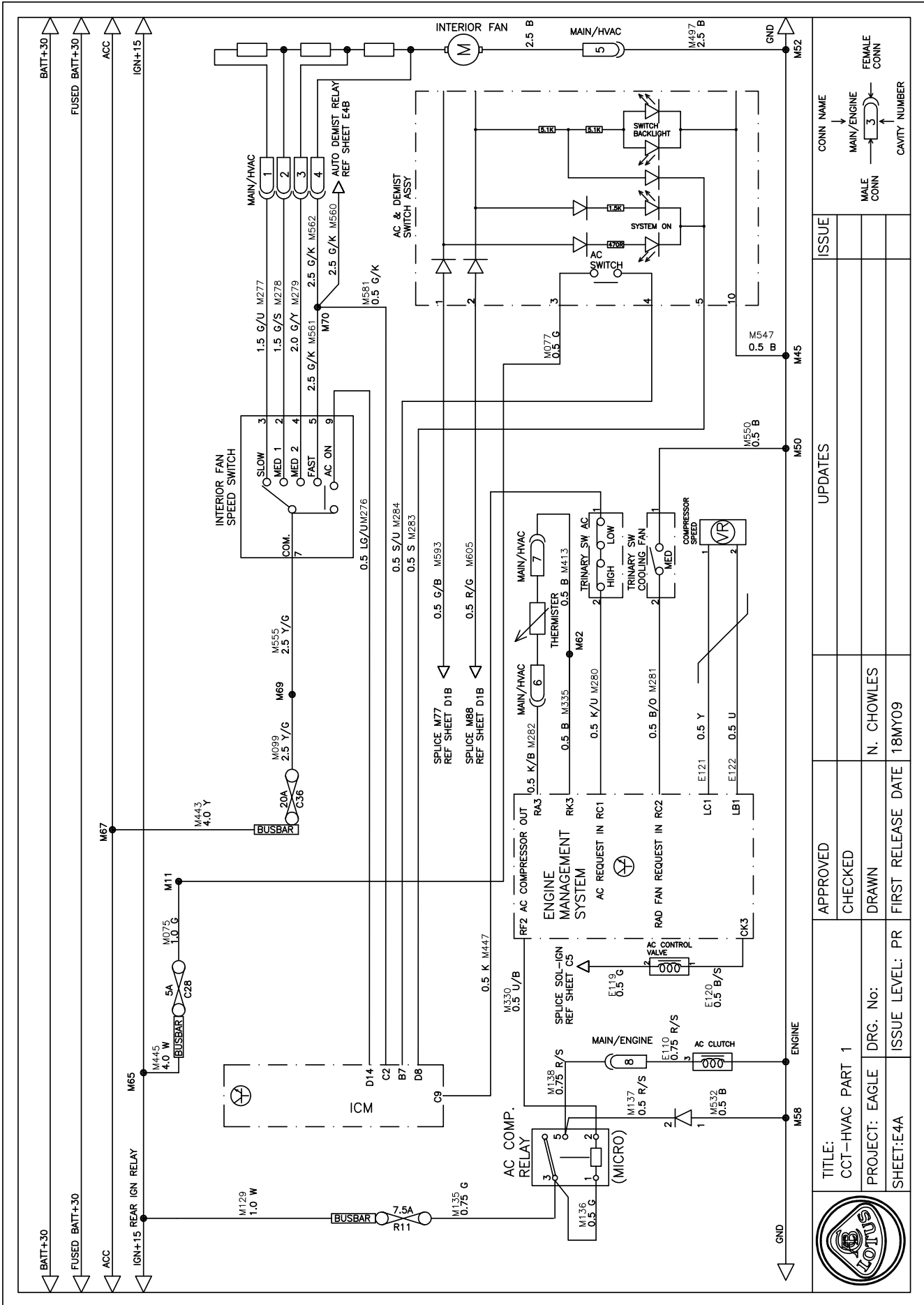

		<b>TITLE:</b> CCT-HVAC PART 1		<b>APPROVED</b> 		<b>ISSUE</b> 	
<b>PROJECT:</b> EAGLE		<b>DRG. No.:</b> N. CHOWLES		<b>CHECKED</b> 		<b>CONN NAME</b> MAIN/ENGINE	
<b>SHEET:</b> E4A		<b>ISSUE LEVEL:</b> PR		<b>FIRST RELEASE DATE</b> 18MY09		<b>MALE CONN</b> 	
						<b>FEMALE CONN</b> 	
						<b>CAVITY NUMBER</b> 	

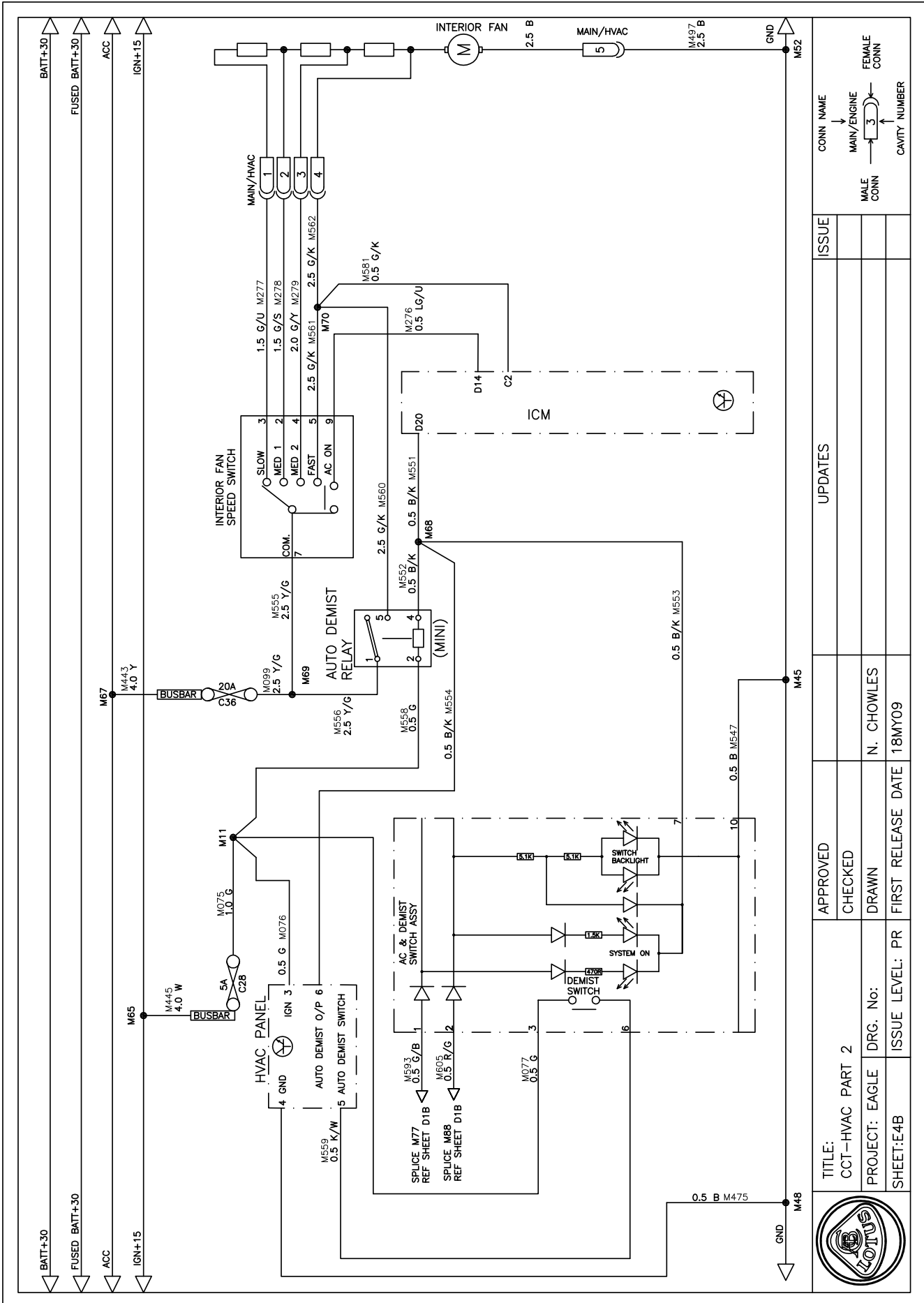

CONN NAME	MAIN/ENGINE	FEMALE CONN
	3	
MALE CONN		CAVITY NUMBER

ISSUE	UPDATES

APPROVED	
CHECKED	
DRAWN	N. CHOWLES
FIRST RELEASE DATE	18MY09

TITLE:	CCT-HVAC PART 2
PROJECT:	EAGLE
DRG. No:	
ISSUE LEVEL:	PR

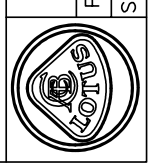

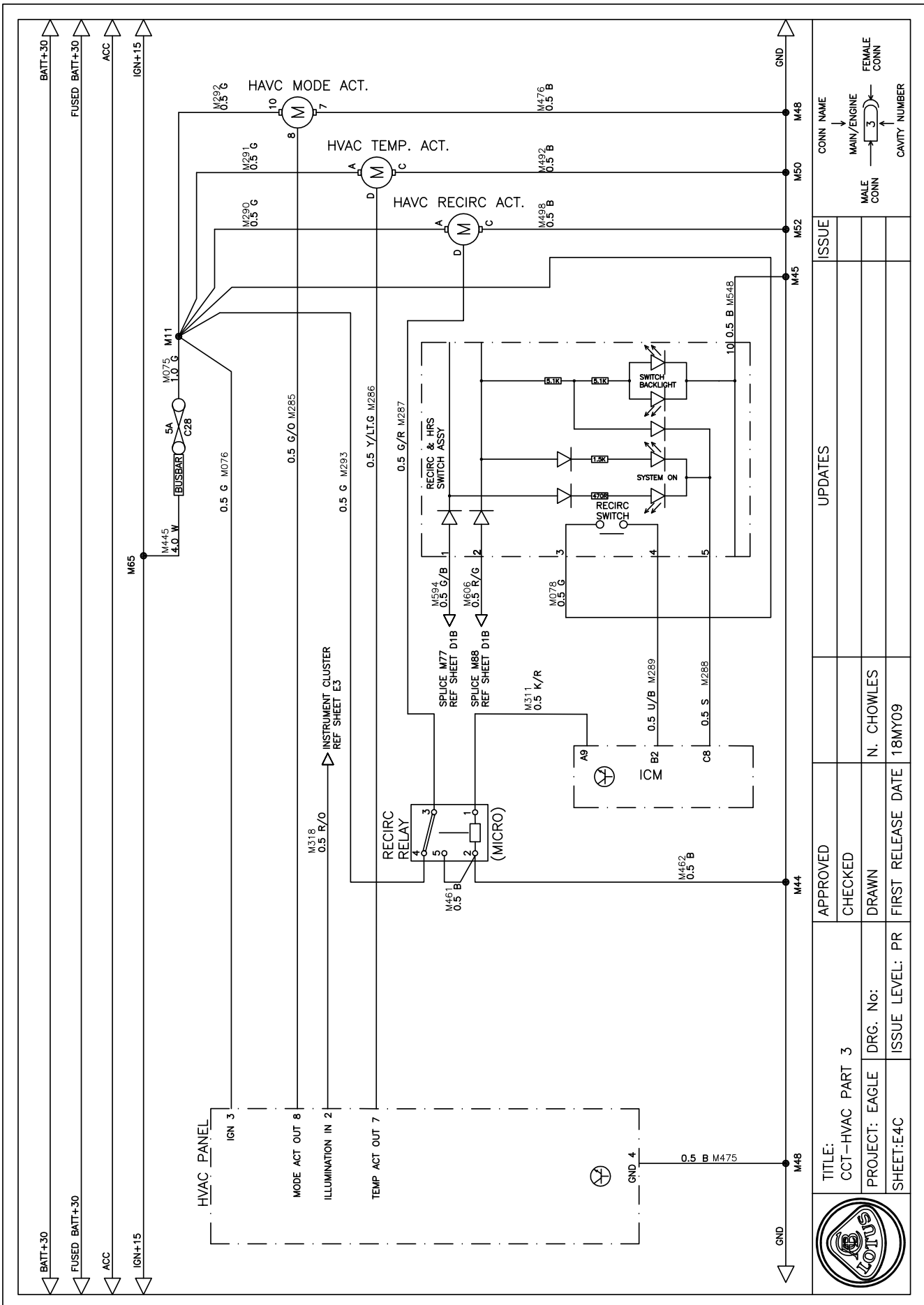



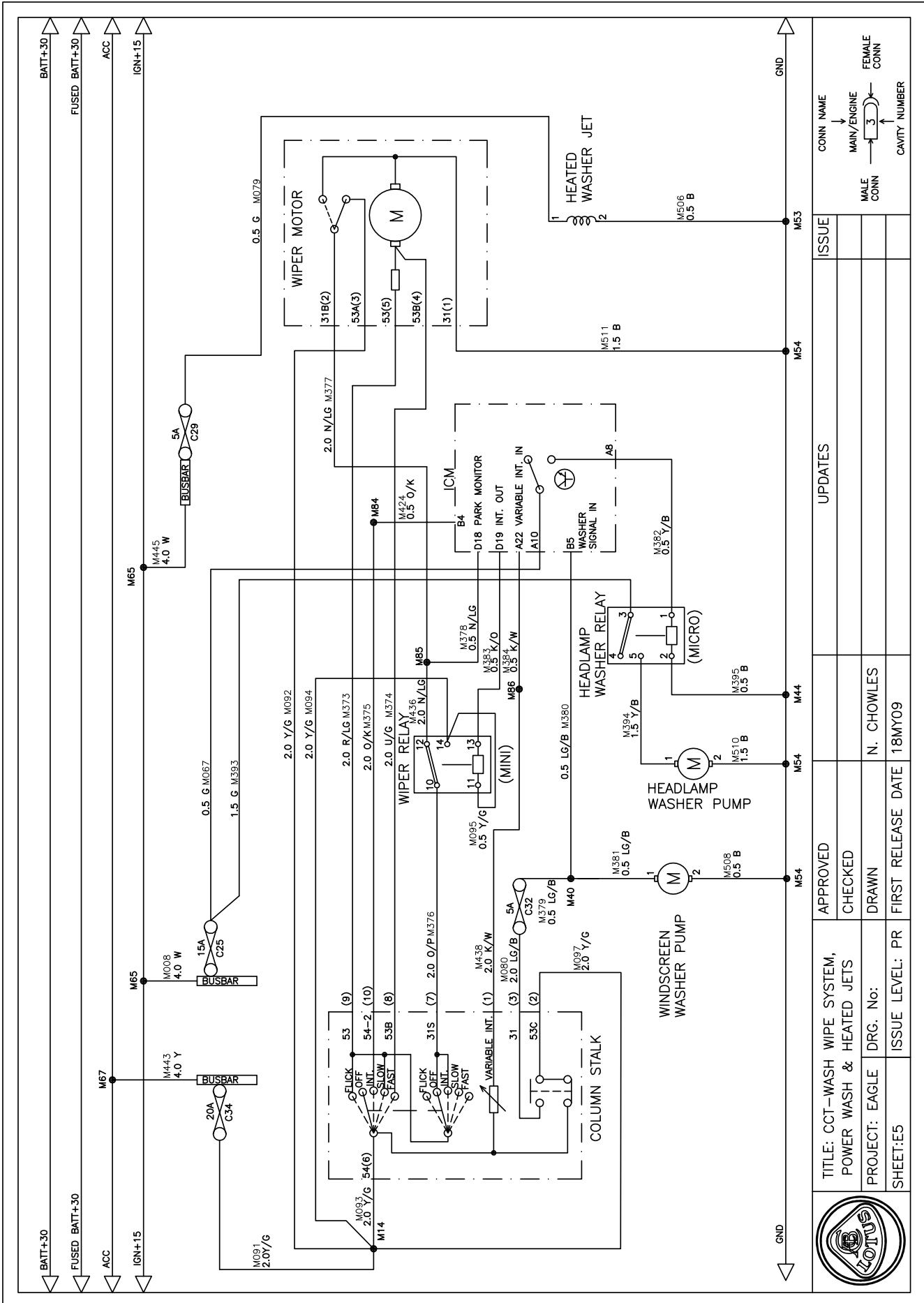

TITLE: CCT-WASH WIPE SYSTEM,  
POWER WASH & HEATED JETS  
PROJECT: EAGLE DRG. No:  
SHEET:E5

APPROVED  
CHECKED  
DRAWN  
FIRST RELEASE DATE

UPDATES  
N. CHOWLES  
18MY09

ISSUE  
CONN NAME  
MAIN/ENGINE  
MALE CONN  
FEMALE CONN  
CAVITY NUMBER

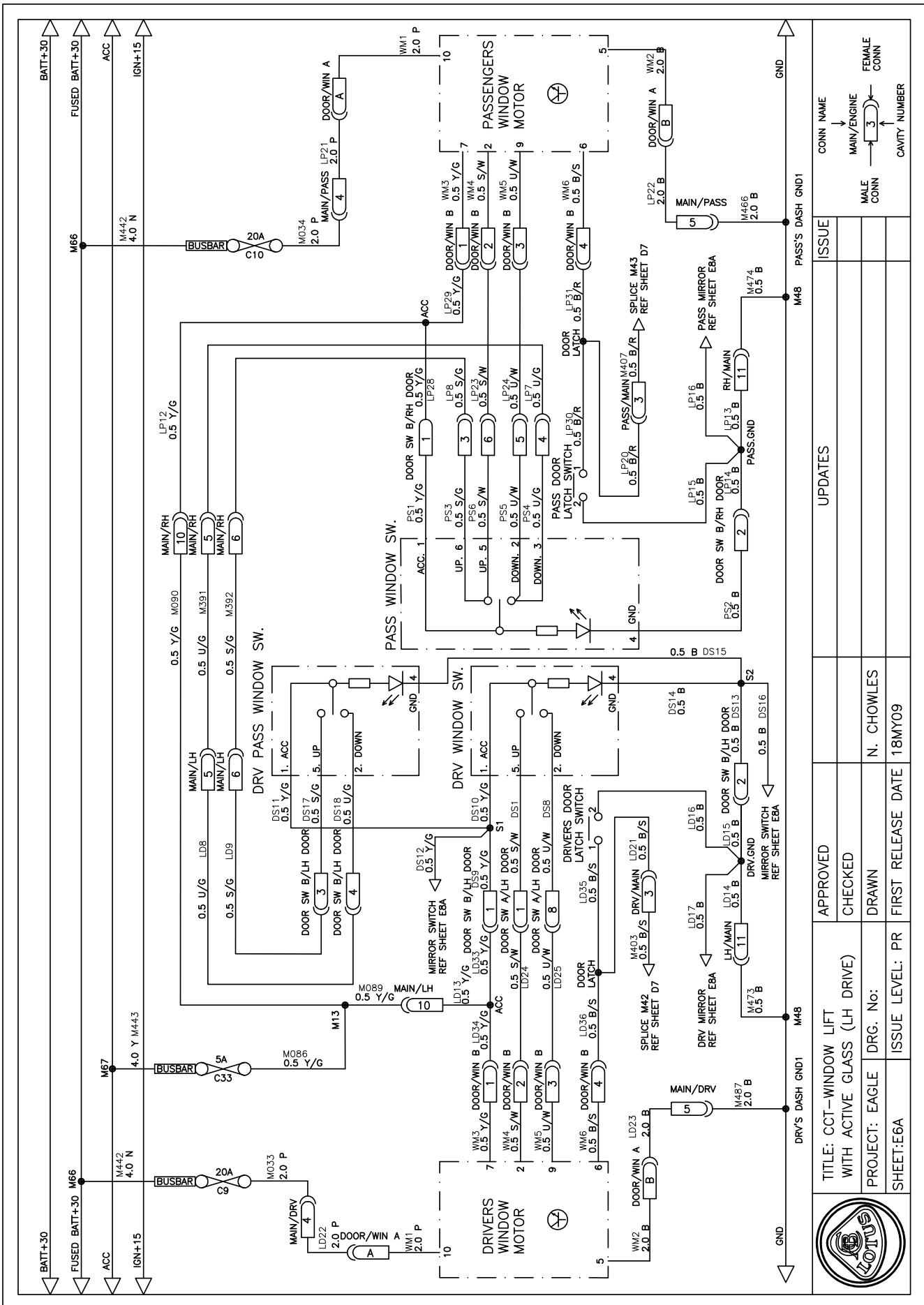

		TITLE: CCT-WINDOW LIFT WITH ACTIVE GLASS (LH DRIVE)		APPROVED		UPDATES		ISSUE	
		PROJECT: EAGLE		DRAWN					
SHEET: EGA		DRG. No: N. CHOWLES		FIRST RELEASE DATE: 18MY09				CONN NAME	
								MAIN/ENGINE MALE CONN → 3 ← FEMALE CONN CAVITY NUMBER	

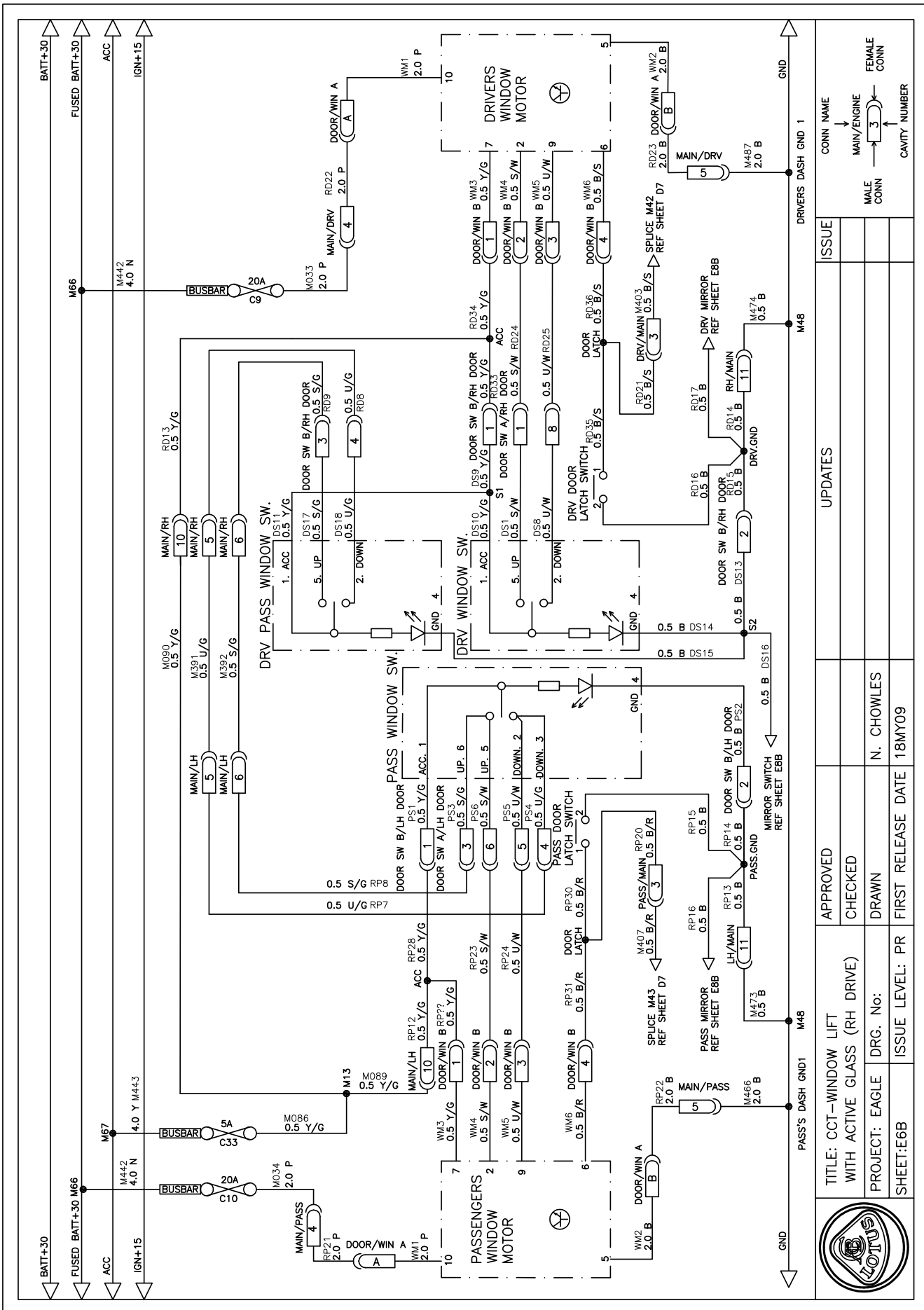

		TITLE: CCT-WINDOW LIFT WITH ACTIVE GLASS (RH DRIVE)	APPROVED	ISSUE
		PROJECT: EAGLE DRG. No: N. CHOWLES	CHECKED	
SHEET:E6B	ISSUE LEVEL: PR	FIRST RELEASE DATE 18MY09	DRAWN	
				CONN NAME MAIN/ENGINE MALE CONN FEMALE CONN CAVITY NUMBER

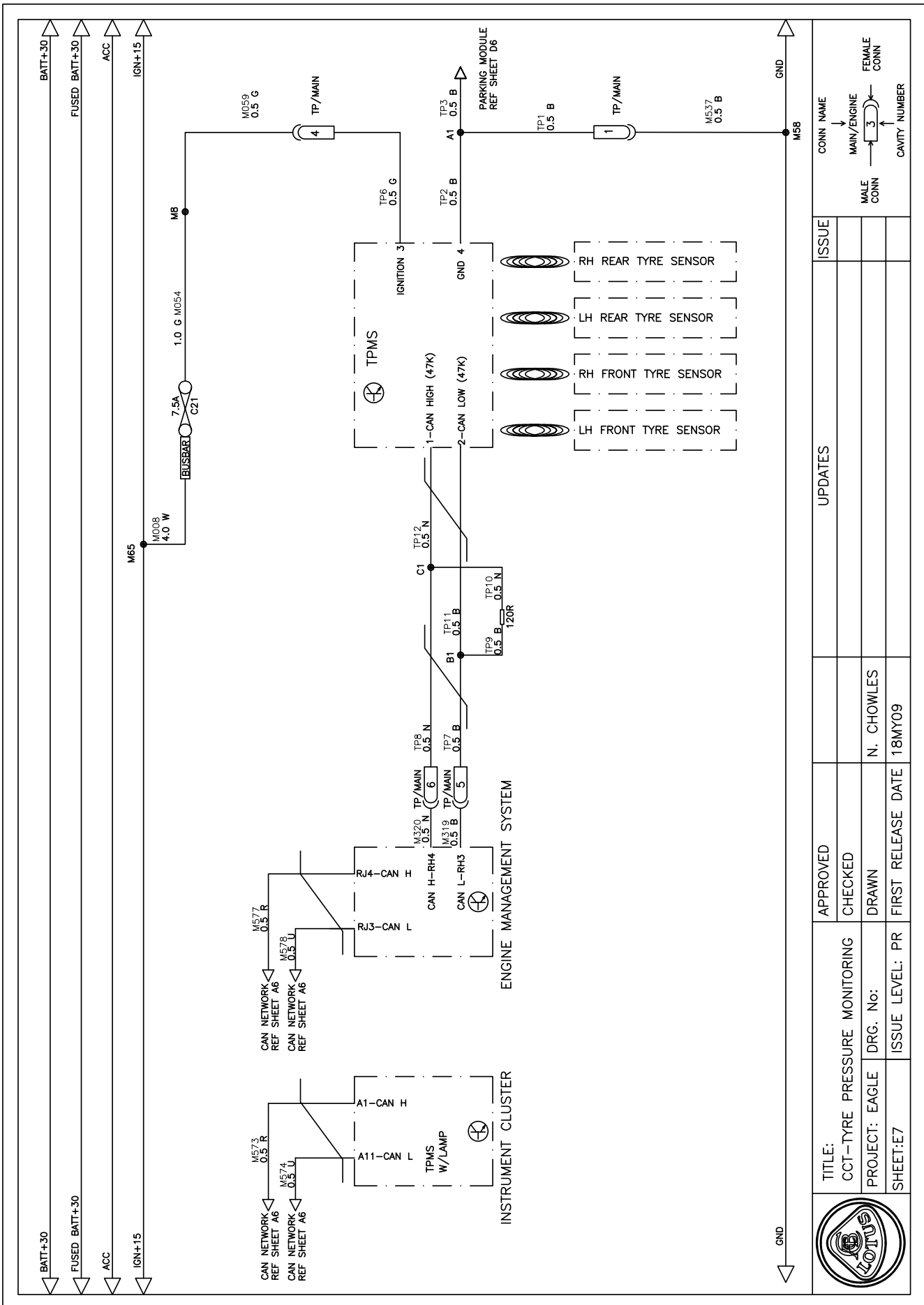

		<b>TITLE:</b> CCT-TYRE PRESSURE MONITORING		<b>APPROVED</b> CHECKED DRAWN FIRST RELEASE DATE		<b>ISSUE</b> UPDATES	
<b>PROJECT:</b> EAGLE		<b>DRG. No.:</b> N. CHOWLES		N. CHOWLES		18MY09	
<b>SHEET:</b> E7		<b>ISSUE LEVEL:</b> PR		1		3	
CONN NAME MAIN/ENGINE		MALE CONN		FEMALE CONN		CAVITY NUMBER	

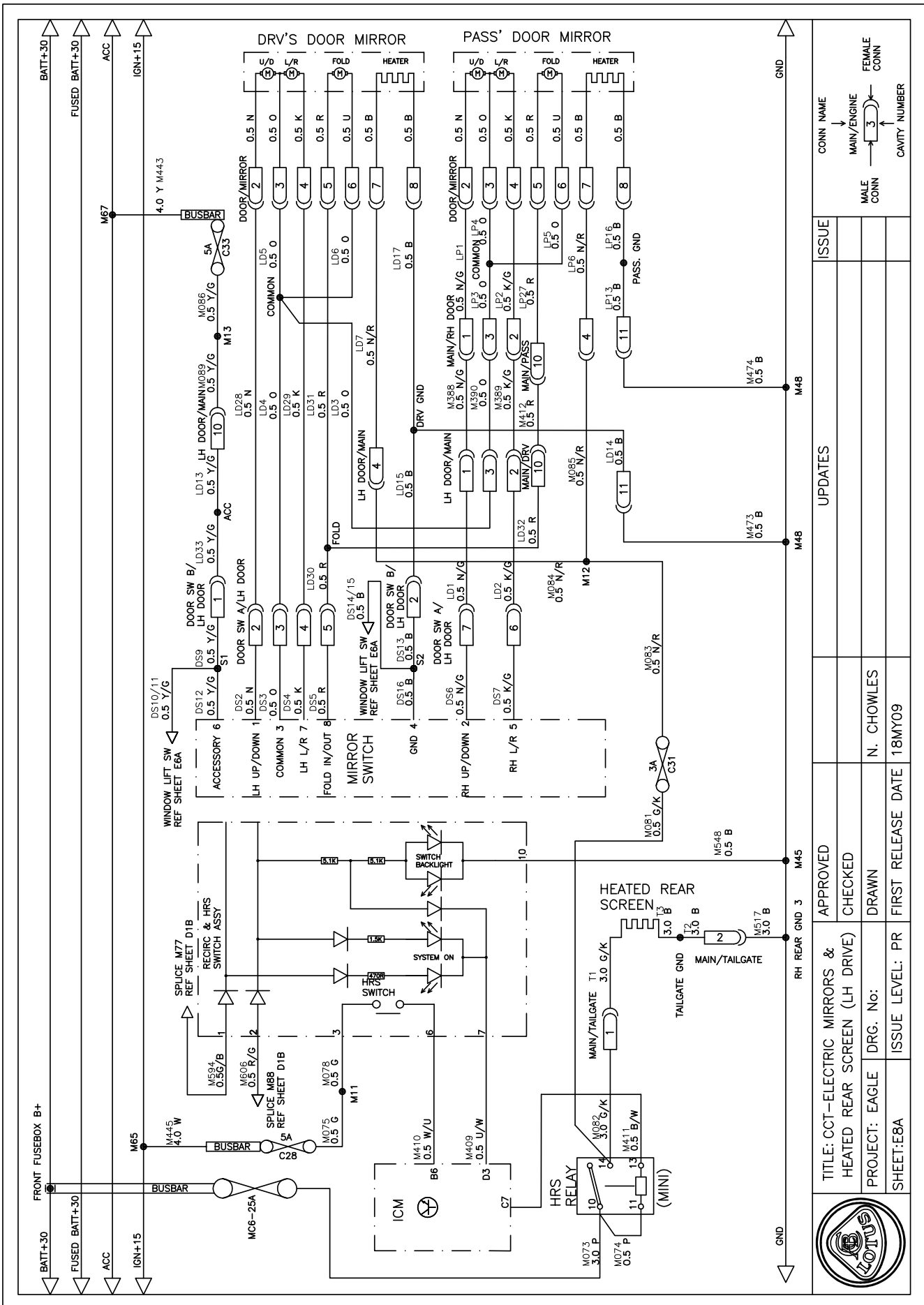

		TITLE: CCT-ELECTRIC MIRRORS & HEATED REAR SCREEN (LH DRIVE)		APPROVED	UPDATES	ISSUE	CONN NAME MAIN/ENGINE MALE CONN FEMALE CONN CAVITY NUMBER
PROJECT: EAGLE		DRG. No:		CHECKED	N. CHOWLES		
SHEET:E8A		ISSUE LEVEL: PR		DRAWN	FIRST RELEASE DATE		
		18MY09					

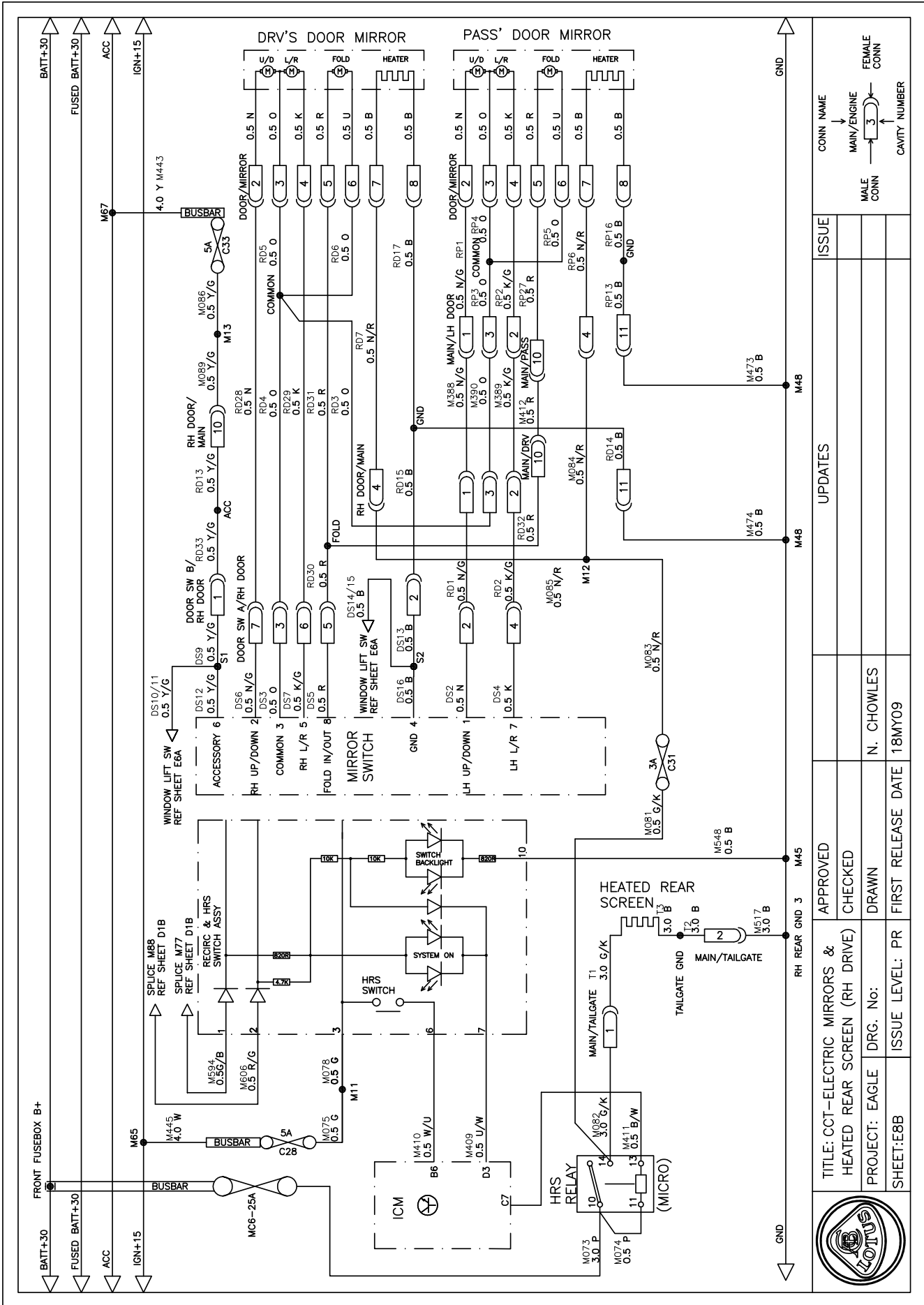

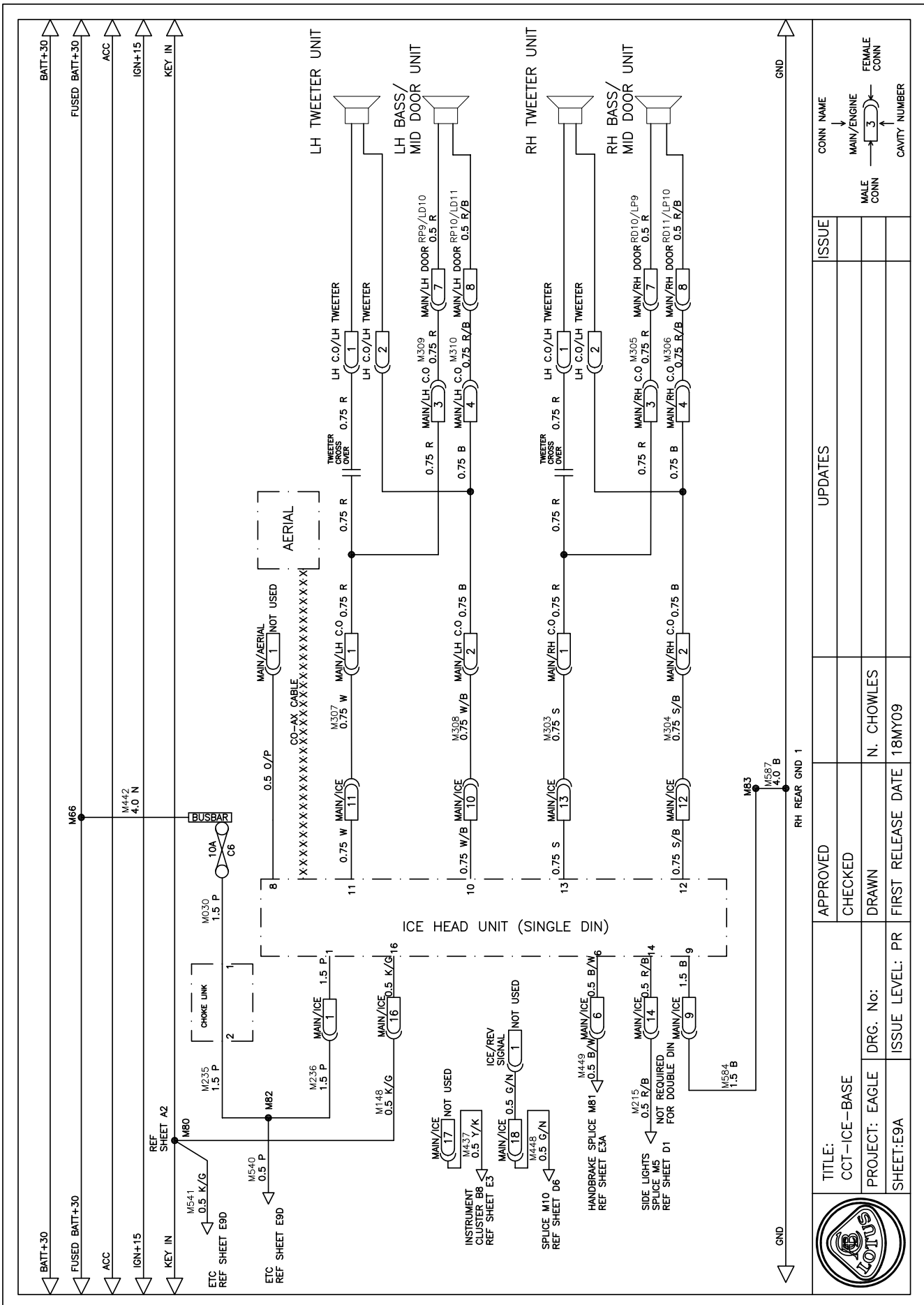

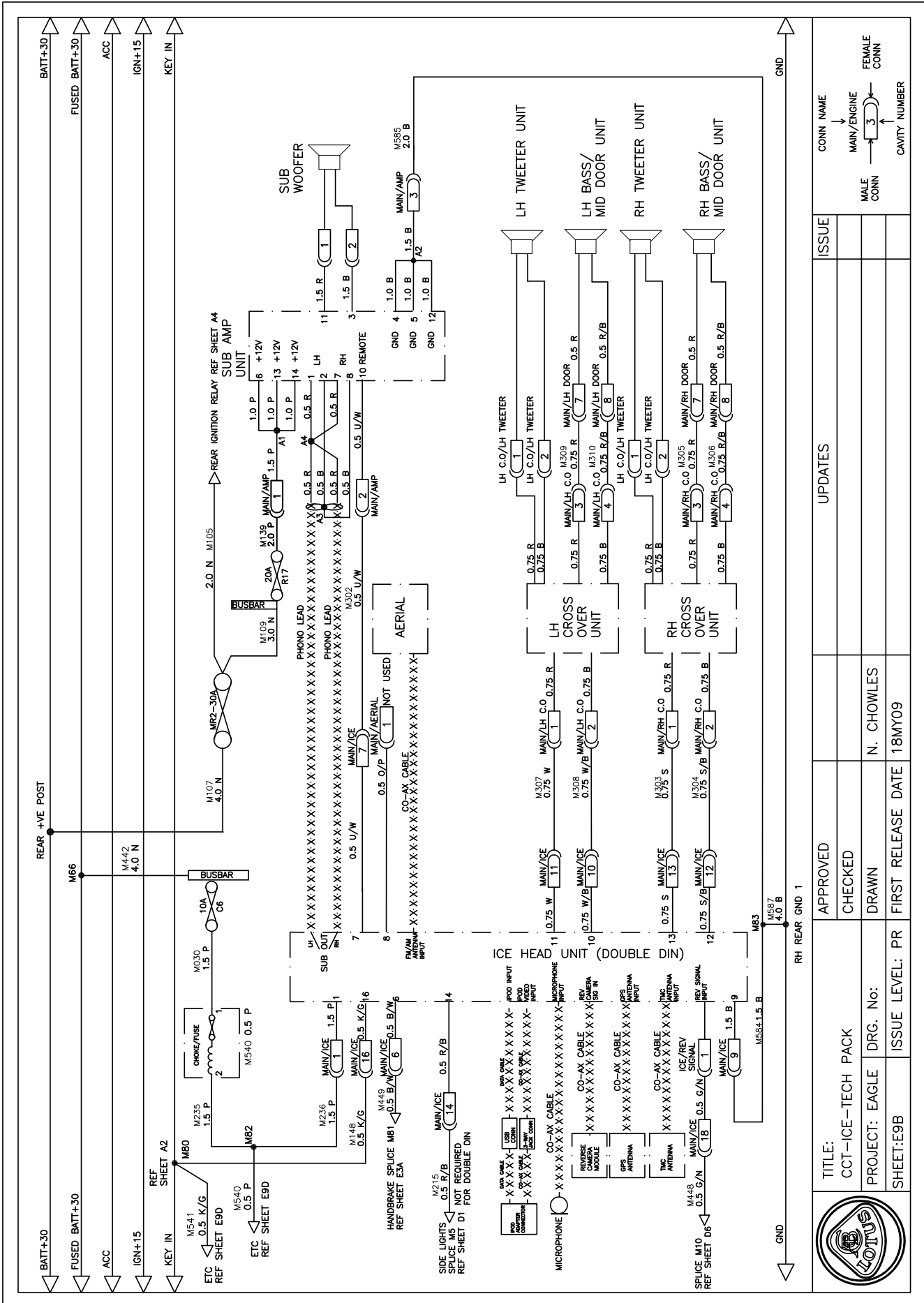

	TITLE:	CCT-ICE-BASE	APPROVED	ISSUE	CONN NAME
	PROJECT:	EAGLE	CHECKED	UPDATES	MAIN/ENGINE
	DRG. No:	N. CHOWLES	DRAWN		MALE CONN
	ISSUE LEVEL:	PR	FIRST RELEASE DATE	18MY09	FEMALE CONN
	SHEET:E9A				CAVITY NUMBER



	TITLE:	CCT-ICE-TECH PACK		APPROVED	UPDATES		CONN NAME
	PROJECT:	EAGLE	DRG. No:	CHECKED			MAIN/ENGINE
	SHEET:	E9B	ISSUE LEVEL:	DRAWN			MALE CONN
			PR	FIRST RELEASE DATE			FEMALE CONN
			18MY09				CAVITY NUMBER

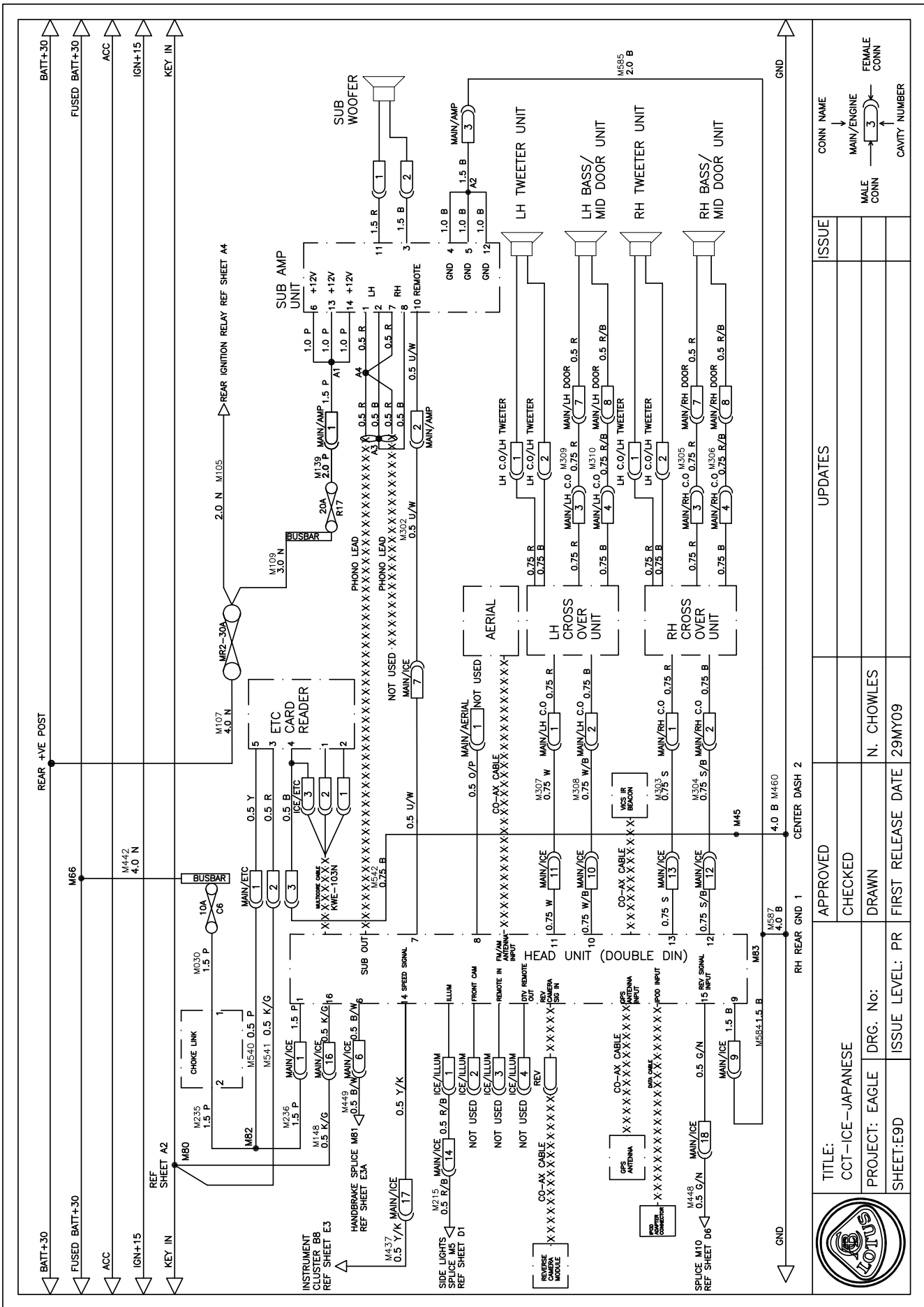



		TITLE: CCT-ICE-JAPANESE PROJECT: EAGLE DRG. No: SHEET:E9D		APPROVED CHECKED DRAWN N. CHOWLES FIRST RELEASE DATE 29MY09		UPDATES		ISSUE	
		CONN NAME MAIN/ENGINE MALE CONN FEMALE CONN CAVITY NUMBER							

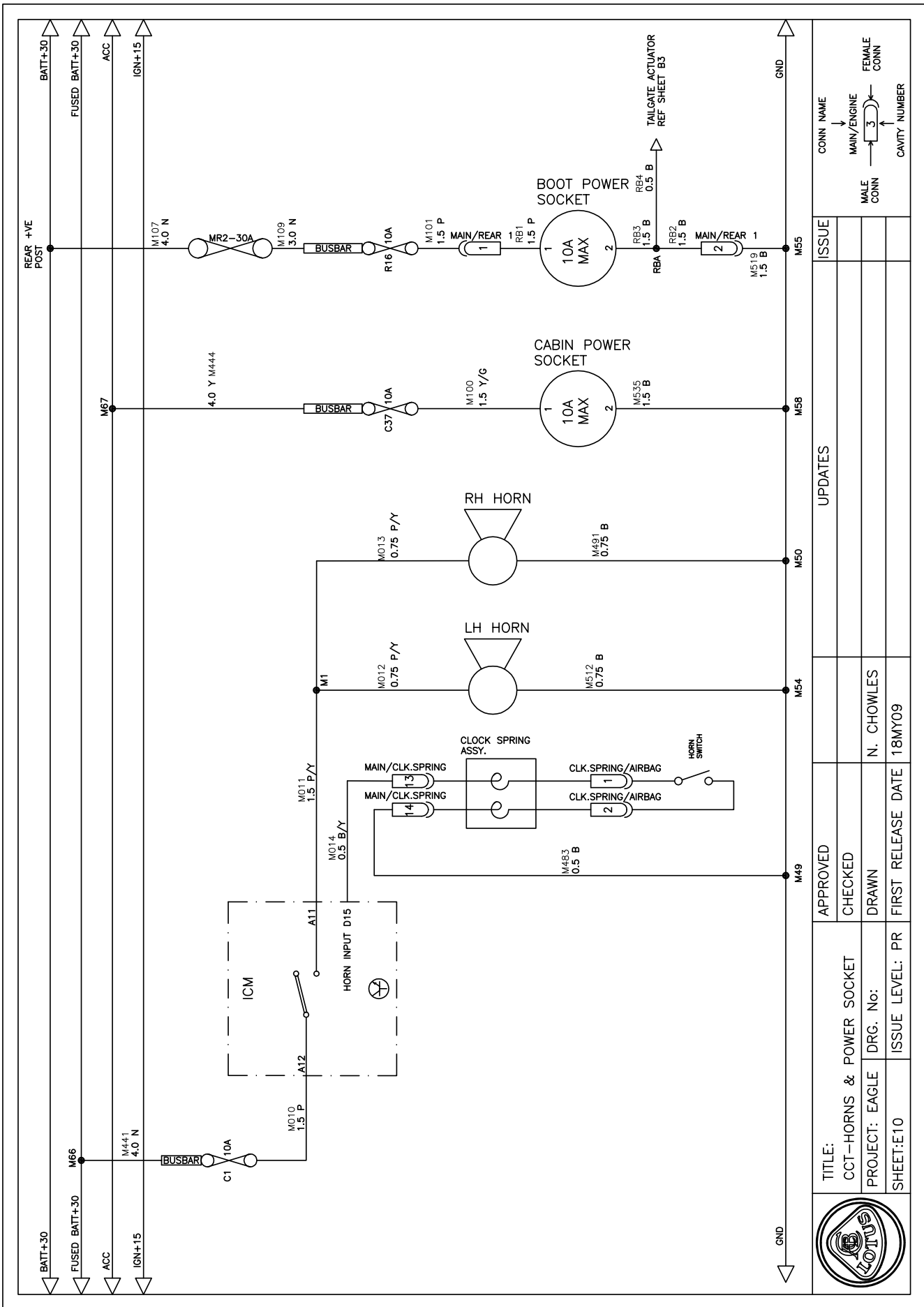

<b>TITLE:</b> CCT-HORNS & POWER SOCKET		<b>APPROVED</b> CHECKED		<b>UPDATES</b>		<b>CONN NAME</b> MAIN/ENGINE	
<b>PROJECT:</b> EAGLE		<b>DRAWN</b> N. CHOWLES		<b>ISSUE</b>		MALE CONN → FEMALE CONN CAVITY NUMBER	
<b>SHEET:</b> E10		<b>ISSUE LEVEL:</b> PR		<b>FIRST RELEASE DATE</b> 18MY09			

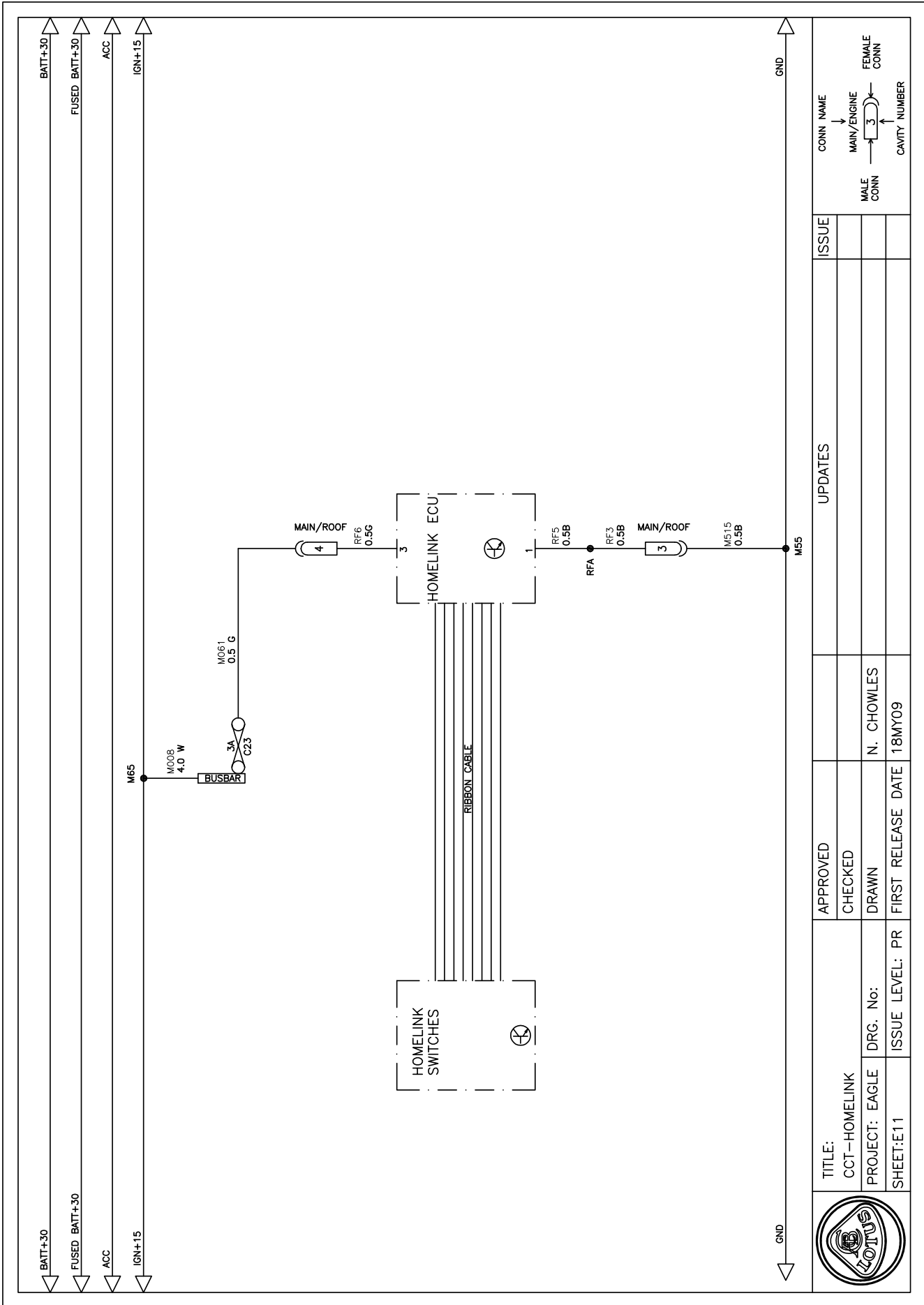

	TITLE: CCT-HOMELINK	APPROVED CHECKED	UPDATES	ISSUE
	PROJECT: EAGLE SHEET: E11	DRAWN N. CHOWLES	FIRST RELEASE DATE 18MY09	CONN NAME MAIN/ENGINE MALE CONN → 3 ← FEMALE CONN CAVITY NUMBER



**MAINTENANCE & LUBRICATION**

SECTION OK

	<u>Page</u>
Recommended Lubricants	2
Maintenance Schedule	4
Pre-Delivery Inspection	7
Pre-Delivery Paint Mark Up	9
Licence Plate Fitment	10

**RECOMMENDED LUBRICANTS****Engine**

In order to ensure the longevity and reliability of the vehicle, it is most important that **only the specified lubricants** are used. It is an entirely false economy to try to save money by using lower quality oils, which may break down before the next change interval and provide inadequate protection before the end of the term. High oil consumption may also result.

For topping up purposes during the running-in period prior to the First After Sales Service, the recommended lubricant is Havoline Ultra 5W/40 semi-synthetic. If this is unavailable, a top quality semi-synthetic 5W/30 or 5W/40 oil should be used.

At the First After Sales Service and completion of the running-in period, a fully synthetic oil should then be used throughout the life of the vehicle. A top quality fully synthetic 5W/40, such as 'Havoline Synthetic' is suitable for all climatic conditions likely to be encountered, and provides ease of cranking, smooth cold running and fuel economy at low temperatures, in combination with good wear protection at elevated temperatures and at high engine speeds. Note that no oil additives are approved by Lotus.

Viscosity: ambient above -20°C	SAE 5W/40
Quality standard	API SL/CF; ACEA A3/B3-04
Capacity: refill inc. filter:	6.1 litre
dry - no heat exchanger	6.8 litre
dry - with heat exchanger	7.1 litre
Difference between high & low dipstick marks	1.0 litre
Oil change interval	Refer to Maintenance Schedule

**Transmission (gearbox & final drive)**

Viscosity	SAE 75W/80
Quality standard	API GL-4
Approved product	Havoline Multigear MTF 75W-80 (semi-synthetic)
Capacity	2.3 litre
Oil change interval	Refer to Maintenance Schedule

**Brake & Clutch System**

Type	Non-mineral (non-petroleum) hydraulic fluid
Specification	DOT 4
Capacity - inc. brake and clutch systems	580 cc
Fluid change interval	24 months

**Power Steering System (PAS)**

Fluid type:	PAS or Automatic Transmission Fluid (ATF)
Specification:	Dexron III
Capacity:	1.5 litres
Fluid change interval:	Not routine

**Engine Coolant Additive**

Approved product	Havoline XLC
Type	Ethylene glycol antifreeze with OAT corrosion inhibitors
Colour	Orange
Quantity reqd. @ 50% concentration	8.5 litres
Coolant change interval	4 years



### 'Severe Service' Conditions

Certain operating conditions can cause rapid degradation of the oil quality, either by the accumulation of dirt particles, or by the absorption of water from condensation. If any of the 'severe service' conditions described below apply, it is recommended that the oil and filter be changed twice as frequently as is listed in the Maintenance Schedule.

- Driving in dusty areas (e.g. on unmetalled roads); Change the oil and filter as soon as possible after driving in a dust storm.
- Stop/start driving with frequent short trips where the engine rarely warms up thoroughly (especially in cold weather/climates); and/or frequent or prolonged idling.
- Track use, with repeated high rpm, wide throttle openings and high oil temperatures. In these circumstances, individual judgement must be made regarding appropriate servicing. Note that use of the car off road or in a competitive manner, including timed runs or laps, will invalidate warranty and require appropriate levels of expert car preparation and servicing.



**MAINTENANCE SCHEDULE - Evora (Non-USA)**

LSL537

Job no.: ..... Owner's name: ..... Vehicle: .....

Vehicle registration no.: ..... V.I.N.: .....

Recorded mileage: ..... Mileage at last service.: .....

Today's date: ..... Date of last service: .....

**EXPLANATORY NOTES:**

**Required Maintenance**

In order to maintain warranty validation and help ensure proper safety, emissions performance and dependability of the vehicle, Lotus Cars Ltd. requires that the vehicle be serviced in accordance with this schedule. Under normal usage conditions, a routine maintenance service should be performed at the first occurring of 9,000 miles (15,000 km) or 12 months from the previous service. The approved service period extends to 500 miles (800 km) before/after or one monthbefore/after the stipulated distance/time. Any necessary repairs should be completed without delay.

A cross ( X ) in the following table indicates an operation to be performed. The corresponding box should be ticked when the operation has been satisfactorily performed, or the X circled if extra work and time is required. The approval of the customer should be obtained before any extra work is undertaken, details of which should be recorded in the space provided at the end of the schedule.

'Inspect' means assess condition and test for correct operation. Extra time is required to adjust or repair - advise customer beforehand if necessary.

'Check' means test and adjust/fill or tighten as necessary. Labour time is included.

**Special Operating Conditions**

If the car is subjected to one of the following 'special operating conditions', additional servicing is required:

- Regular use on unpaved or dusty roads (1,2)
- Use in mountainous areas with severe or prolonged brake usage (3)
- Frequent short trips with cold engine (esp. in cold weather/climates); and/or frequent or prolonged idling (1)
- Occasional hard use, with repeated high rpm, wide throttle openings and high oil temperatures (1,3,4)
- Competition, or track use - not endorsed by Lotus and voiding the Warranty (5)

*Additional servicing:*

1. Oil & filter change @ 4,500 m (7,500 km) intervals.
2. Inspect air cleaner @ 9,000 m (15,000 km) intervals, or as required.
3. Inspect brake pads & discs @ 4,500 m (7,500 km) intervals, or as required.
4. Thorough safety check including wheels, tyres, suspension, steering and brake systems.
5. The Evora is intended for use as a road going passenger vehicle. IT IS NOT DESIGNED OR INTENDED FOR USE OFF ROAD, INCLUDING ON CLOSED CIRCUIT TRACKS OR FOR USE IN A COMPETITIVE MANNER, INCLUDING TIMED LAPS OR RUNS. ANY SUCH USE WILL INVALIDATE THE NEW VEHICLE WARRANTY. If an owner elects to use the Evora on a closed circuit track or in a competitive manner, the severity of operating conditions demands that appropriate levels of expert car preparation, servicing (over and above that specified in the Maintenance Schedule) and vigilance will be required, including careful inspection of all safety critical components both before and after any track or competition session.

**After Sales Service**

To be performed within 1,000 - 1,500 miles (1,500 - 2,500 km) or 12 months of vehicle sale, whichever first occurs.

If carried out by the selling dealer, there is no charge to the vehicle owner for the labour content of the After Sales Service. Only for materials used will a charge be made. To maintain warranty validation, an Engine History Report print out from the Lotus TechCentre must be submitted to the Warranty Department.



Op. No.	Operation Description	Service Type		
		After Sales	9,000m (15,000km) or 12 months	Other Intervals
1	Fit protective covers to seats, footwells, steering wheel and rear body	X	X	
<b>Lubrication</b>				
2	Renew engine oil and filter - <i>normal conditions</i>	X	X	
2a	Renew engine oil and filter - <i>special conditions</i>		4,500m (7,500km)/6 mth	
3	Inspect engine & transmission for oil leaks	X	X	
4	Renew manual transmission oil		36,000m (60,000km)/4 yr	
<b>Engine</b>				
5	Inspect air cleaner element - <i>normal conditions</i>		X	
5a	Inspect air cleaner element - <i>dusty conditions</i>		As required	
6	Renew air cleaner element - <i>normal conditions</i>		36,000m (60,000km)/4 yr	
6a	Renew air cleaner element - <i>dusty conditions</i>		As required	
7	Renew spark plugs		54,000m (90,000km)	
9	Inspect auxiliary drive belt condition		X	
10	Inspect integrity of fuel system		X	
11	Inspect for fault codes & ECU programme level	X	X	
12	Print Engine History & Performance reports and return to Lotus	X		
<b>Cooling System</b>				
13	Inspect water radiator & pipework for damage or leaks. Clean radiator finning		X	
14	Check coolant level	X	X	
15	Renew coolant			4yrs
<b>Braking System</b>				
16	Inspect parking brake adjustment	X	X	
17	Inspect brake pad thickness & disc condition - <i>normal condts.</i>		X	
17a	Inspect brake pad thickness & disc condition - <i>special condts.</i>		4,500m (7,500km)	
18	Inspect brake hoses, pipes & hydraulic units		X	
19	Check brake fluid level	X	X	
20	Renew brake/clutch fluid		18,000m (30,000km)/2 yr	
<b>Steering &amp; Suspension</b>				
21	Check security and condition of front & rear suspension		X	
22	Inspect dampers for leaks and performance		X	
23	Inspect front and rear wheel bearings for play		X	
24	Inspect condition of drive shaft gaiters		X	
25	Inspect steering ball joints and gaiters		X	
26	Inspect free play at steering wheel		X	
<b>Wheels &amp; Tyres</b>				
27	Inspect tyre condition & set pressures	X	X	
<b>Electrical</b>				
28	Check battery & terminals for security & condition	X	X	
29	Inspect operation of all lights	X	X	
<b>Body</b>				
30	Inspect operation & adjustment of hinges and latches, manual door locks	X	X	
31	Inspect operation & condition of seat belts		X	
32	Inspect wiper operation & top up windscreen washer reservoir	X	X	
33	Renew pollen filter		18,000m (30,000km)/2 yr	
34	Renew alarm transmitter batteries (check with customer)			1 yr





**Road Test Performance**

Engine performance .....	Tailpipe CO .....
Clutch operation .....	Gearbox operation .....
Brake performance .....	Steering performance .....
Driveline & suspension noise/vibration .....	Wheel balance .....
General comments .....	
.....	
.....	

**Additional Work Performed or Required**

.....

.....

.....

.....

Work completed by ..... Owner's Maintenance Booklet stamped: .....

**Recommended Service Times**

After Sales Service: 1.9 hr  
 Regular Service: 2.8 hr  
 Op. 2a: 0.6 hr  
 Op.4: 0.4 hr  
 Op.5a: 0.1 hr  
 Op.6a: 0.7 hr  
 Op.7: 0.6 hr  
 Op.15: 1.0 hr  
 Op.17a: 0.1 hr  
 Op.20: 0.6 hr  
 Op.33: 0.1 hr  
 Op.34: 0.1 hr

Dealer Stamp:

Date:



<h2 style="margin: 0;">PRE-DELIVERY INSPECTION</h2> <p style="margin: 0;">LSL345E </p>
--

<b>MODEL</b>		<b>COLOUR</b>		<b>VIN</b>	<b>SCC</b> _____
--------------	--	---------------	--	------------	------------------

OPERATION DESCRIPTION	✓
Fit protective covers to seats, footwells & steering wheel.	<input type="checkbox"/>
<b>Engine Bay</b>	
Check engine, transmission & PAS oil levels.	<input type="checkbox"/>
Check coolant fill level.	<input type="checkbox"/>
<b>Start Engine</b>	
Inspect engine & transmission for oil leaks.	<input type="checkbox"/>
Inspect cooling system for leaks.	<input type="checkbox"/>
Fill fuel tank and inspect entire fuel system for leaks.	<input type="checkbox"/>
Use Lotus TechCentre to check for stored codes.	<input type="checkbox"/>
<b>Wheels &amp; Tyres</b>	
Check cold tyre pressures.	<input type="checkbox"/>
Check torque of wheel bolts.	<input type="checkbox"/>
Check tyreweld canister is fitted in rear luggage compartment.	<input type="checkbox"/>
<b>Electrical</b>	
Check security of battery terminals and voltage. Below 12.4V recharge. Below 11.7V replace*.	<input type="checkbox"/>
Inspect operation of alarm system, CDL & fuel flap release.	<input type="checkbox"/>
Inspect operation of all exterior & interior lamps.	<input type="checkbox"/>
Inspect operation of horn & hazard switch.	<input type="checkbox"/>
Inspect wiper operation at all speeds & park position.	<input type="checkbox"/>
Inspect screen washer & powerwash operation, jet alignment & reservoir level.	<input type="checkbox"/>
Inspect operation of all instruments, mirror adjustment & fold.	<input type="checkbox"/>
Inspect operation of heater / air conditioning & blower fan.	<input type="checkbox"/>
Inspect operation of audio equipment & set time clock (if applicable).	<input type="checkbox"/>
<b>Body</b>	
Check brake / clutch fluid level.	<input type="checkbox"/>
Inspect operation of doors, door locks & tailgate release (incl. Evora cable).	<input type="checkbox"/>
Inspect operation of electric window lift mechanism.	<input type="checkbox"/>
Inspect fit of hard & soft top roofs.	<input type="checkbox"/>
Inspect seat adjustment latching & operation of front & rear seatbelts.	<input type="checkbox"/>
Inspect interior trim for damage & cleanliness.	<input type="checkbox"/>
Inspect all paint work for damage (Elise LSL407a; Exige LSL409a; Europa LSL514; Evora LSL544).	<input type="checkbox"/>
Check presence of toolkit & literature pack.	<input type="checkbox"/>
Fit number plates and tax disc holder.	<input type="checkbox"/>
<b>Complete Warranty Literature</b>	
Check presence of vehicle handbook, audio booklet & other documentation.	<input type="checkbox"/>
Complete pages 2, 3, 4a & 4c in "Maintenance Record" booklet.	<input type="checkbox"/>
Cut out pages 4a & 4c for return to Lotus Cars Warranty Department.	<input type="checkbox"/>
Copy alarm installation certificate, PIN & key details (inc. locking wheel bolts). Originals to customer.	<input type="checkbox"/>
<b>U.K.:</b> Complete Lotus Roadside Assistance card (expiry date 2 years from reg. date).	<input type="checkbox"/>
<b>* Battery claims will not be accepted unless correct trickle charging has been maintained.</b>	



Road Test Performance Check - Add comments as necessary		
Engine performance:		
Brake performance:		
Clutch operation:		
Gearbox operation:		
Steering performance:		
Check wheel balance:		
Driveline/suspension noise/vibration:		
General Comments		
Additional Work Required		
<b>Additional Work Completed by:</b>		
Valet		
Undertake complete vehicle valet.		

**Notes - The PDI is subject to the following conditions:**

- a) It is the responsibility of the supplying dealer to ensure that the car is delivered to the customer in the best possible condition.
- b) All costs incurred during the inspection process are the responsibility of the dealer.
- c) Failure to return a signed copy of this inspection to Lotus Cars Ltd. by the dealer, may result in warranty claims on the particular car being rejected.

**Dealer stamp:**

<b>Pre-Delivery Inspection Completed by:</b>	
<b>Date:</b>	

ONCE COMPLETED, SEND ORIGINAL COPY OF PDI FORM, OWNER'S HANDBOOK MAINTENANCE RECORD PAGES "P.D.I & REGISTRATION OF SALE", AND NEW CAR HANDOVER CHECKLIST (LSL486) TO:

**WARRANTY DEPARTMENT,  
 LOTUS CARS LTD.  
 POTASH LANE,  
 HETHEL,  
 NORFOLK,  
 NR14 8EZ,  
 ENGLAND**



PRE-DELIVERY PAINT MARK UP - EVORA

Is1544

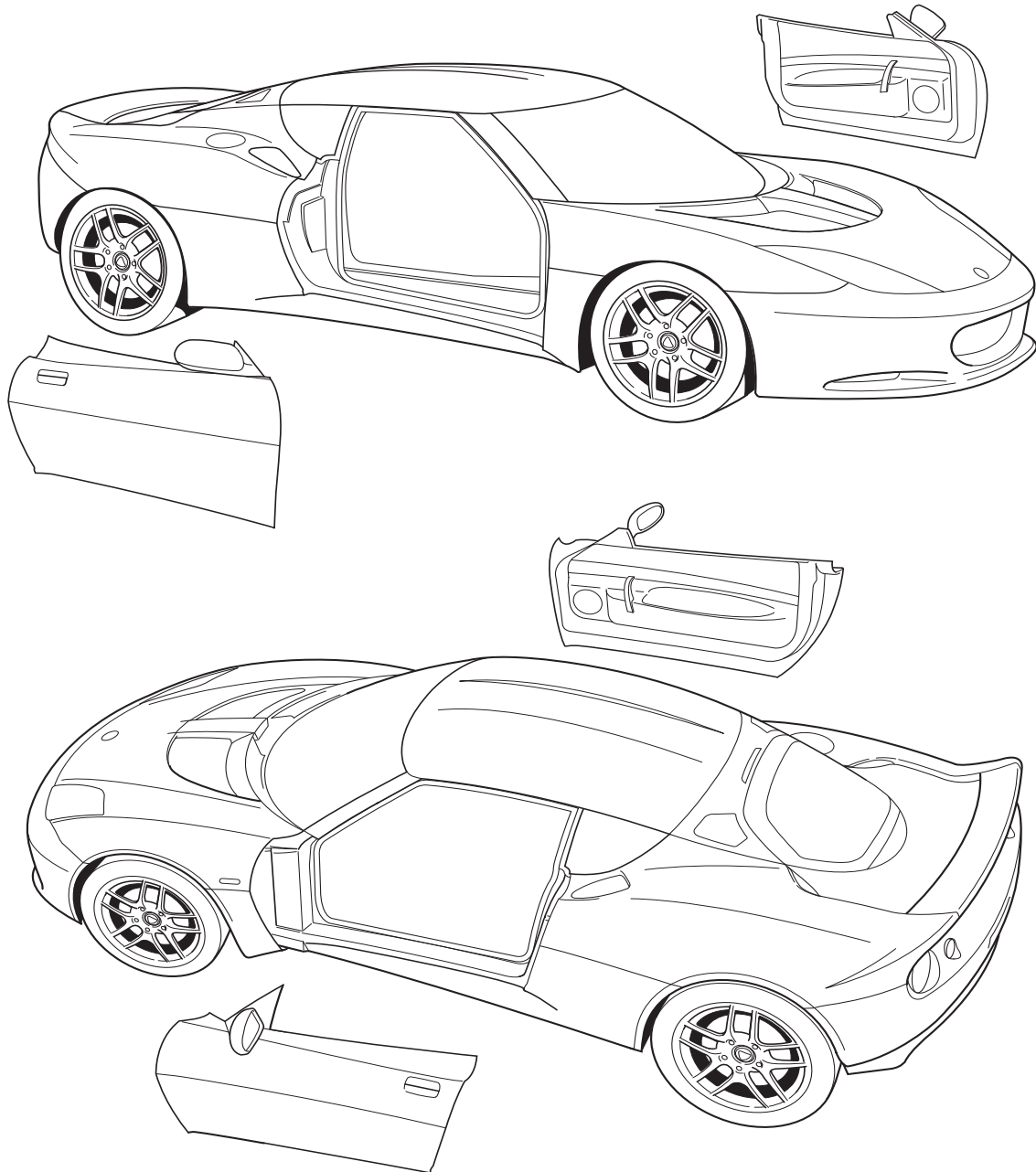

<b>VIN</b>	
<b>COLOUR</b>	
<b>OWNER</b>	
<b>DATE OF PDI</b>	

PAINT DEFECT CODE	
B	BLISTERING
C	CHIPS
D	DISTORTION
F	FLAKING
G	GEL CRAZING
H	PIN HOLES
K	SINKAGE
M	MAT CREASES
N	SHADING
O	OVERSPRAY
P	PRE-RELEASES
R	RUN
S	SCRATCHES
T	THIN PAINT
U	DIRT UNDER PAINT
V	VOIDS



### Licence Plate Fitment

#### *Front*

The mounting plinth for the front licence plate is screw fixed to the front clamshell, and is slightly curved in plan. Typically, the plate is secured using double sided tape in conjunction with two fixing screws with suitable blind fix nuts (e.g. Rawlnuts). The plate should be aligned with the bottom edge of the plinth to reduce potential damage from grounding or kerbs, whilst providing the minimum restriction to radiator airflow.

#### *Rear*

The rear licence plate should be mounted on the surface of the rear transom recess using double sided tape and/or fixing screws at the dealer's/customer's discretion. Ensure that any holes drilled through the body are suitably weather sealed.



## AIR CONDITIONING, HEATING & VENTILATION

### SECTION PN

	<u>Sub-Section</u>	<u>Page</u>
General Description	PN.1	3
Heater/A.C. Airflow Overview	PN.2	5
Cooling Fans & Re-circulation Pump	PN.3	9
Refrigerant Handling	PN.4	10
Refrigerant Pipework Precautions	PN.5	10
Refrigerant Oil	PN.6	12
Compressor	PN.7	12
Condenser	PN.8	14
Receiver-Drier	PN.9	15
Heater/Evaporator/Fan (HVAC) Unit	PN.10	15
Air Distribution Unit (ADU)	PN.11	16
Refrigerant Pipes	PN.12	17



**Heater Circuit**

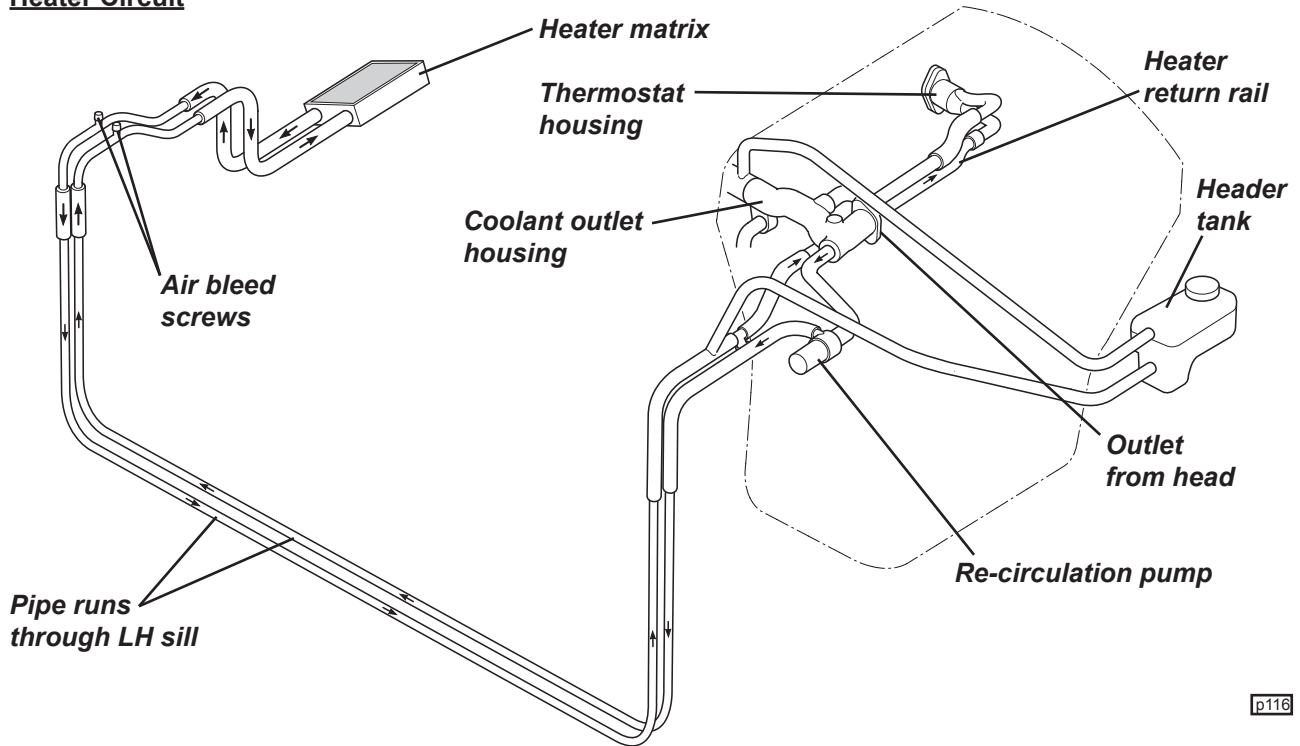

p116

**Refrigerant Circuit**

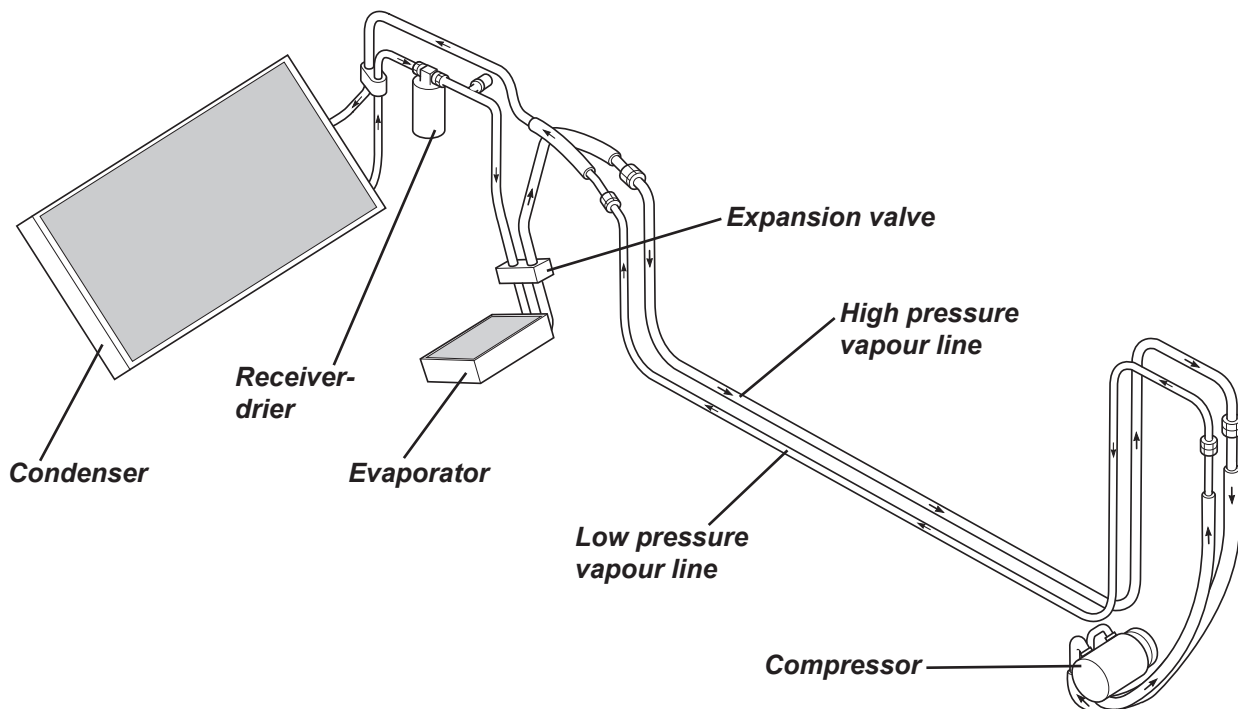

p115



### PN.1 - GENERAL DESCRIPTION

The heating, ventilation and air conditioning (HVAC) main unit comprises a plastic casing secured to the front face of the main chassis tub, housing the fan blower, a.c. evaporator and heater matrix, with a fresh air inlet adaptor on its top face, a re-circulation intake port on the rear face, and an outlet to the air distribution chamber on the top rear of the unit.

#### **Heater Circuit**

The heating system uses engine coolant to provide a heat source transferred to the interior airstream via a heat exchanger matrix mounted within the HVAC unit. Hot coolant is directed from an offtake on the engine outlet housing at the rear of the cylinder head, via a re-circulation pump (see below), into pipework running through the LH sill, and connecting to the heater matrix. The outlet from the matrix connects to return pipework routed alongside the supply line to the LH end of the heater return rail. This rail runs down the 'V' of the cylinder block, alongside the by-pass pipe, and connects to the engine side of the thermostat housing at the front of the engine.

In conditions of 'heat soak', after stopping a hot engine, the electric re-circulation pump mounted in the heater supply line at the LH side of the engine bay, is energised under engine ECU control, to pump coolant around the heater circuit and limit the potential for localised boiling within the cylinder head.

#### **Air Conditioning - Basic Principles**

The air conditioning unit uses a variable displacement compressor system with a thermostatic expansion valve to provide refrigerated air to the vehicle interior. The system comprises:

- a closed circuit containing refrigerant R134a;
- a variable displacement compressor mounted on the front side of the engine, driven by multi-vee belt from the front end of the crankshaft via an electromagnetic clutch;
- a condenser fixed to the front of the engine cooling radiator, between the front subframe longerons and tilted forwards at 45°;
- an evaporator unit (cooler) contained within the HVAC housing ahead of the cabin footwell bulkhead;
- a thermostatic expansion valve fitted at the inlet connection to the evaporator;
- a refrigerant receiver-drier unit mounted on the outside of the front subframe RH longeron, ahead of the RH front wheel.

#### *Closed Circuit*

The closed refrigerant circuit should not be opened unless absolutely necessary, and only then using appropriate refrigerant recovery equipment. Never allow the refrigerant to vent to atmosphere. Refer to sub-section PN.5. Failure to observe these precautions may result in personal injury.

The discharge hose from the engine driven compressor connects to a rigid aluminium pipe at the RH side of the engine bay, with the junction supported on an vibration isolator plate. The high pressure discharge pipe is routed through the RH body sill via foam support blocks clamped to the outside of the chassis main siderail. At the rear of the RHF wheelarch, the pipe rises to another junction plate secured to the outside of the subframe longeron, where it connects to the condenser supply pipe/hose assembly which runs over the wheelarch area to the RH side of the condenser, to which it connects on the topline. The condenser outlet union is sited alongside the inlet union, and supplies a rigid aluminium pipe running to the receiver-drier unit mounted ahead of the RHF wheelarch. From here, another pipe, incorporating the trinary switch, connects to the expansion valve mounted on the evaporator inlet pipe at the RH side of the HVAC unit. Refrigerant leaving the evaporator passes through the expansion valve into a pipe/hose assembly which connects to a sill pipe and then continues to run in parallel to the supply line back to the compressor.



**Compressor**

The variable displacement compressor is mounted on the front side of the engine, and is driven by the multi-rib auxiliary belt. The compressor operates to discharge refrigerant vapour at high pressure and temperature into the condenser and is lubricated by a quantity of special refrigerant oil, most of which is retained in the compressor, with the remainder being circulated with the refrigerant. The compressor contains a ring of cylinders with axes parallel to the compressor drive shaft, and whose pistons are driven up and down the bores by a rotating 'swash plate', the angle of which, in relation to the drive shaft, is variable. With a small swash plate angle, a short piston stroke is produced for a low refrigerant flow; a high swash plate angle results in greater piston stroke for a higher flow of refrigerant. The angle of the swashplate is determined by the pressure differential between that on top of the pistons, and that within the housing, applying a force to the underside of the pistons, in conjunction with a coil spring around the drive shaft.

This differential is controlled by a solenoid valve under ECU control, using pulse width modulation. When the valve is open, the output from the cylinders is bled off to the compressor housing to result in no pressure differential. The angle of the swashplate is then determined by the coil spring which pushes the plate to a near neutral position to provide minimal flow. As the valve is progressively closed, the pressure differential increases, with the pressure on top of the pistons pushing the swashplate to a greater angle, and producing an increased refrigerant flow.

The engine ECU is programmed to minimise refrigerant flow until an a.c. request is made, thus allowing the compressor to be run at all times in the interests of system lubrication, and the reduction of inactivity damage.

To safeguard the drive system in the event of compressor seizure, an electromagnetic clutch in the pulley hub is used to disengage the drive as signalled by a sensor in the compressor nose. The clutch will also be disengaged by the ECU if a loss of refrigerant is detected by the trinary switch (see below).

Hot refrigerant vapour from the compressor is fed via flexible hoses and alloy pipework routed through the body RH sill, to the front mounted condenser.

**Condenser**

The aluminium condenser is a 'parallel flow' heat exchanger, configured with side mounted collector tanks interconnected by 40 oval shaped, horizontal tubes, all provided with generous finning. The unit is fixed to the front of the engine cooling radiator, sited between the longerons of the front subframe, and angled forwards at 45°. The hot vapour received from the compressor, is admitted into the top section of the RH condenser tank, and flows through 32 tubes to the LH tank before returning to the lower section of the RH tank via the bottom 8 tubes. In so doing, heat is released to the surrounding air via the condenser finning, with airflow boosted by two electric fans mounted on top of the engine radiator, and ram air flow caused by vehicle movement.

A union at the bottom of the RH tank directs the condensed, liquid refrigerant into pipework connecting with the receiver-drier.

**Receiver-Drier**

The receiver-drier unit is fitted into the refrigerant line between the condenser and evaporator expansion valve, and houses a screen sack filled with desiccant to absorb traces of moisture and other contaminants from the refrigerant. The unit is mounted on the outside of the subframe RH longeron, ahead of the RHF wheel.

A trinary switch fitted into the pipe between the receiver-drier and expansion valve supplies a pressure signal to the engine ECU, which then allows system operation only within a pressure range of 2 to 32 bar in order to prevent system damage from too high a pressure, or from compressor oil starvation damage caused by too low a pressure. This data is also used by the ECU to engage the two condenser fans at half speed at pressures over 17.5 bar (see also sub-section KJ.5).

**Expansion Valve**

The expansion valve block is fitted into the high and low pressure pipes at the evaporator connection, and provides a variable restriction to the flow of high pressure liquid into the evaporator, such that the consequent pressure drop causes a change of state to a low pressure, low temperature atomised liquid.

By sensing the temperature and pressure of refrigerant leaving the evaporator, the expansion acts to modulate the flow of refrigerant into the unit to optimise the cooling performance.



**Evaporator**

The evaporator is a 'serpentine' type heat exchanger mounted within the HVAC unit. The low pressure liquid refrigerant flowing into the evaporator via the expansion valve, begins to boil (evaporate) and in so doing, draws the necessary heat for this process from the airstream passing across the evaporator finning. This airstream is consequently cooled, and is directed through the various outlet vents to the passenger compartment.

When the a.c. switch is pressed by the driver, and other parameters allow it (i.e. ignition on, blower fan speed selected, a.c. system pressurised, ambient temperature above 3°C), the a.c. circuit is activated and refrigerant flow established. A thermostat, using a thermistor positioned against the outlet side of the evaporator finning, monitors the temperature of the refrigerated air and signals the ECU to regulate refrigerant flow in order to provide an output air temperature just above that at which ice may form on the evaporator.

The inlet and outlet pipes connect to the evaporator via the expansion valve block, into which they are sealed using 'O' rings and a clamp plate. The inlet is supplied from the receiver-drier, and the outlet feeds into pipework routed through the body RH sill, to the compressor.

**Ventilation**

Air in the cabin is exhausted via an outlet vent at the left hand side of the rear bulkhead, and another at the bottom right hand corner of the bulkhead. Ducting from each of these vents connects to the rear luggage compartment, from which air escapes to atmosphere through two one-way flap valves fitted in the rear transom and concealed by the rear bumper.

PN.2 - HEATER/A.C. AIRFLOW OVERVIEW

The HVAC unit comprises left and right hand plastic mouldings sandwiched together and containing a pair of blower fans supplied from two intake sources, an a.c. evaporator, a heater matrix, and two electrically controlled flaps; one for the fresh air intake and one for the heater matrix.

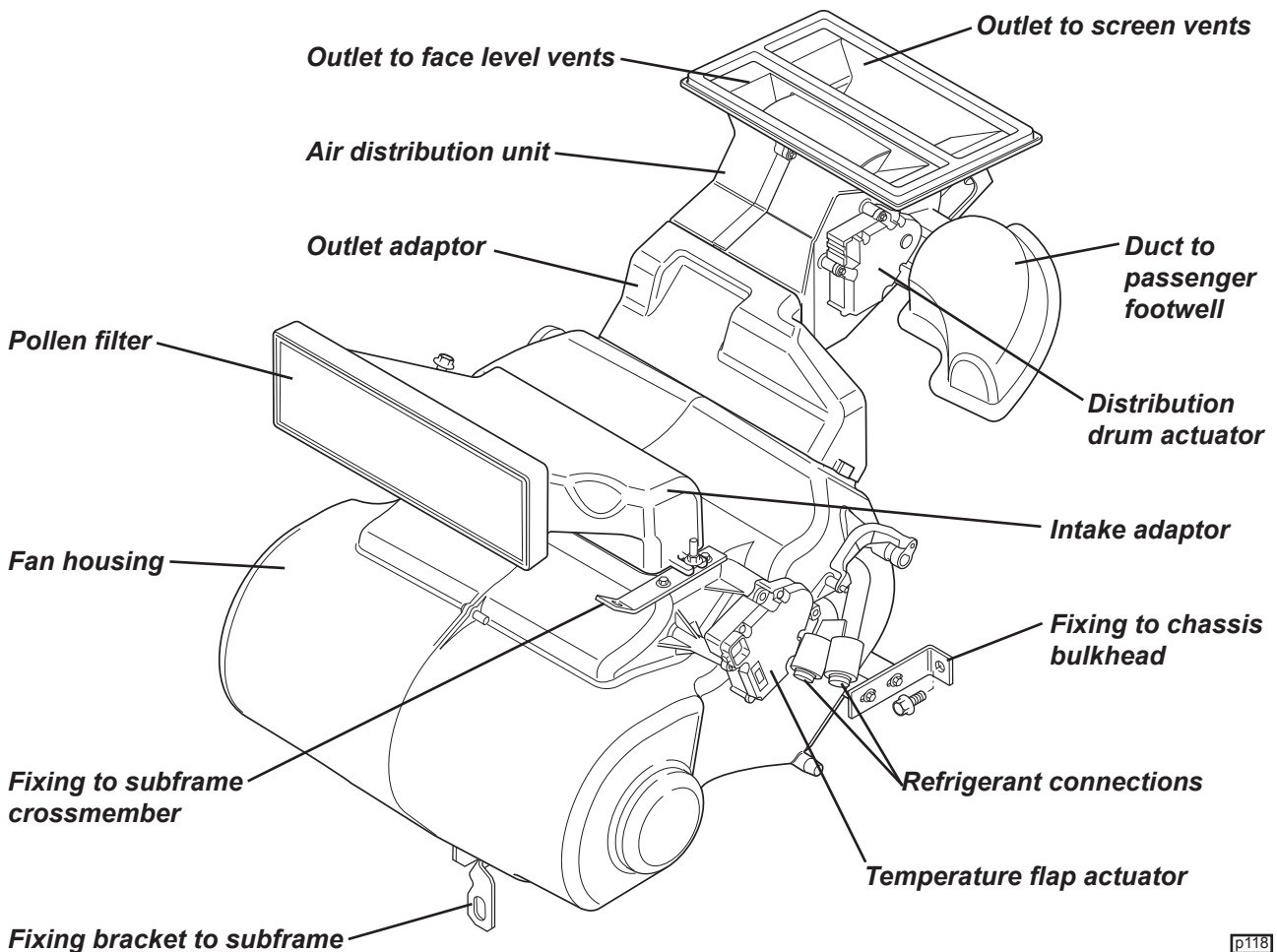

p118



Ambient air collected from the top of the intake duct, ahead of the engine radiator, is fed via an insulated fibreform duct to a pollen filter mounted at the intake to the HVAC unit, within which the airflow is divided towards the inner and outer sides of the two blower fans. Air enters the fan drums axially and is centrifuged outwards to be directed into the evaporator chamber. A second intake duct collects air from the cabin interior via a central aperture in the footwell toeboard, from which the air flows through a duct formed in the lower section of the HVAC unit and into the fan chamber in a similar manner to the ambient flow. Electrical resistors used in the fan speed circuitry are cooled by the incoming airflow stream. The fresh air intake may be closed off at the driver's request by an electrically operated flap at the top of the unit, which closes or fully opens the ambient air intake. The re-circulation intake is open at all times.

All air exiting the fan chamber is directed through the evaporator, whether or not a.c. is selected, and is then divided between routes flowing either past, or through the heater matrix by an electrically operated air blender flap, the position of which is determined by the temperature selector knob. Blended air then leaves the top rear of the HVAC unit and enters the Air Distribution Unit (ADU) which passes beneath the base of the windscreen and is secured to the top of the footwells. A part cylindrical rotary mask on a horizontal axis, controls the airflow exiting the ADU into a top mounted port for the windscreen vents, an adjacent port for the face level vents, and, via a port in each end plate of the mask, to outlets supplying a duct in the top of the passenger footwell, and through the inboard side of the pedal box. The rotation of the mask is driven by a stepper motor (common with the air intake and air blender actuators) mounted on the left hand side of the ADU.

### Interior Climate Controls

The interior climate control panel is located on the centre console and consists of three rotary control knobs, for air distribution, temperature and fan speed, and four button switches, for air conditioning, demist, air re-circulation and heated rear screen. When the sidelamps are switched on, the rotary control graphics are backlit white and red/blue by an electro-luminescent panel, with red lit pips in the knobs to indicate their position. The button switches are backlit red with ignition or sidelamps switched on, and will light up brightly (HRS and demist in amber) when activated. Press the switch a second time to switch off. Climate control functionality requires the ignition to be on, and for refrigeration and heat production, the engine needs to be running.

#### Distribution Control

This rotary control is positioned at the top of the HVAC panel and allows a choice of air distribution from the various outlet vents. There are 5 designated positions with corresponding symbols, although there is a progressive transition from each airflow mode to the next, allowing a preferred balance to be attained.



Face level vents

**To face level vent ducting in underside of fascia top panel**

**Air distribution unit**

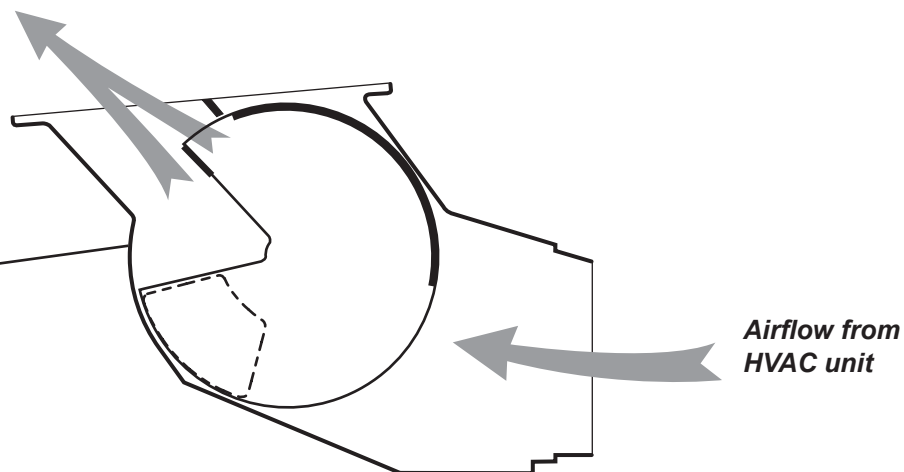



Face level vents & footwells

*To face level vent  
ducting in underside  
of fascia top panel*

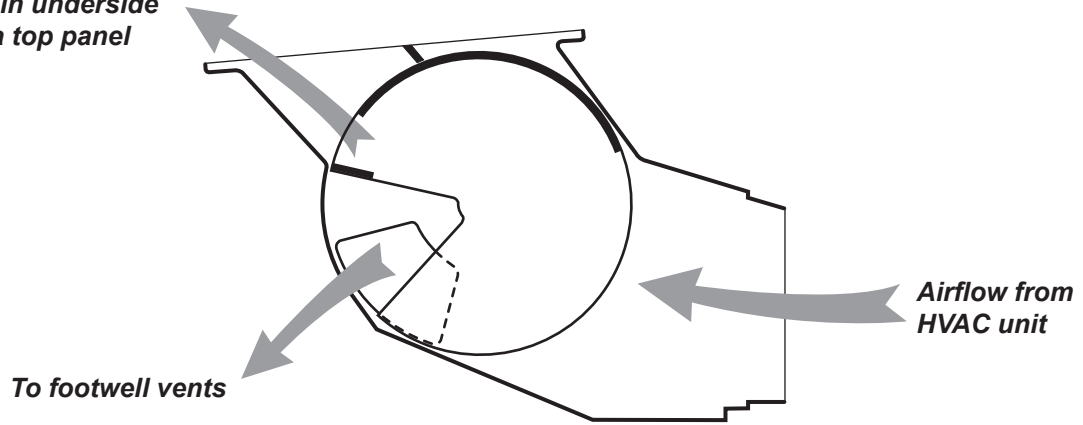

Footwell vents

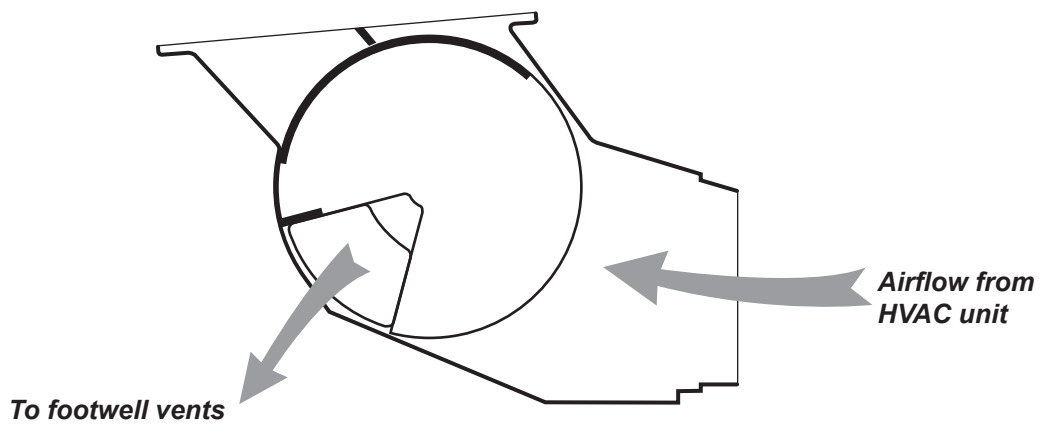

Footwells & windscreen

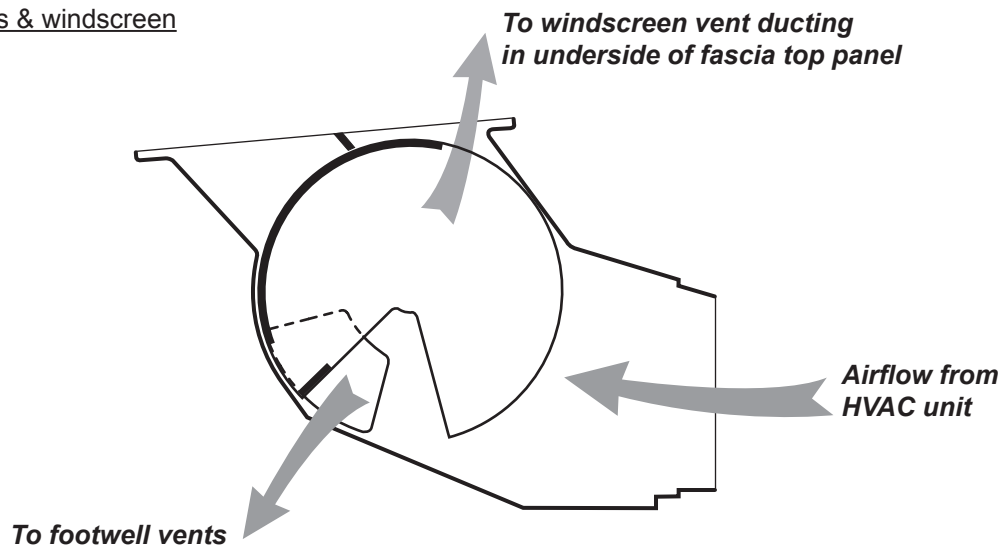



Windscreen

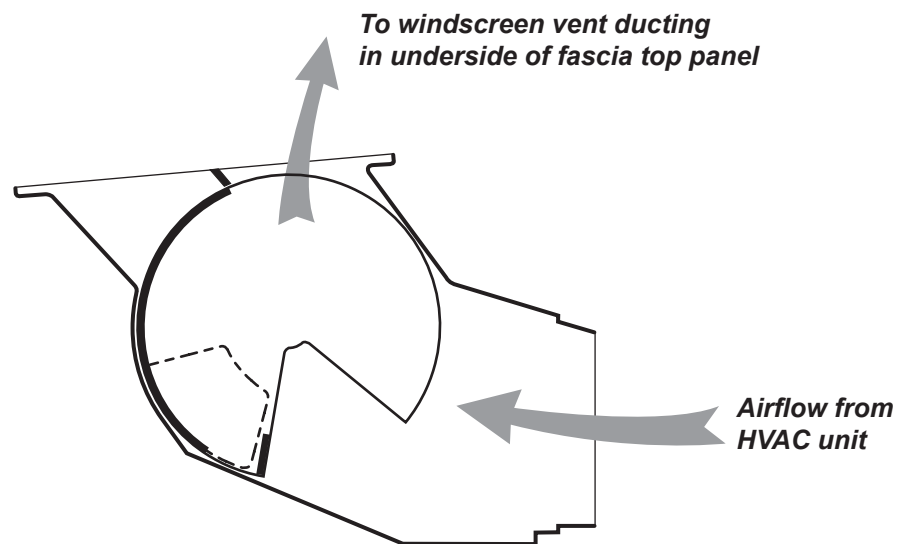

### *Temperature Control*

The rotary temperature control actuates the air blender flap, which dictates the proportion of the airflow which is directed through the heater matrix. With the control knob fully clockwise at the coldest position, the heater matrix is fully shut off. As the control is turned counterclockwise, the flap is moved to allow some airflow through the heater matrix, until at the fully hot position, all airflow is directed through the matrix for maximum heating.

### *Interior Fan*

The lowermost of the rotary controls, allows the selection of 4 speeds for the interior fan, and functions with the key at the accessory or ignition positions. Turned fully clockwise, the fan is switched off. Turning the knob counterclockwise through 4 detent positions provides increasing fan speed and airflow delivery. Note that the air conditioning will not function until a fan speed is manually selected.

### *Re-circulation Switch*

This switch functions with the key at the accessory or ignition positions, and will maintain its status throughout ignition cycles.

The re-circulation port in the footwell toe-board is open at all times, such that the greater proportion of air drawn into the fan chamber, via a duct incorporated into the bottom of the HVAC housing, is always from the cabin interior. The fresh air intake on the top of the unit is controlled by a stepper motor and flap valve, and is normally open to provide approximately 30% fresh airflow. To close the intake and prevent fumes being drawn into the cabin, or to provide the quickest response to temperature change requests, the fresh air intake may be closed off by pressing the re-circ. switch, to result in 100% re-circulation. This option should, however, be used sparingly to avoid stuffiness in the cockpit.

### *Air Conditioning Switch*

The engine must be running for the a.c. to operate. This switch signals the engine ECU with an air conditioning request, and will maintain its status throughout ignition cycles. The ECU determines whether the running conditions allow for compressor activation. Conditions which will inhibit a.c. include:

- near full throttle demand;
- excessive coolant temperature;
- any fault codes set;
- low refrigerant pressure.

When appropriate, the ECU will activate the a.c. by applying a duty cycle to the compressor solenoid valve, thus generating a swash plate angle and initiating refrigerant flow.

### *Demist Switch*

In order to allow a single touch selection of demist/defrost settings, a dedicated switch is provided. The switch is operative only with ignition on, and will default off at the next ignition cycle. When activated:



- The interior fan will operate at full speed;
- All airflow will be directed to the windscreen;
- Air conditioning will be switched on (may be overridden by manual de-selection).  
Note that an appropriate temperature setting must be selected manually.

### Heated Rear Screen

Due to the heavy current demand, this switch will operate only when the engine is running. Under this condition, the HRS and door mirror heating elements will be activated for a period of 10 minutes before automatically switching off. The switch and heating cycle will default off next time the ignition is turned on.

### Pollen Filter

Mounted at the air intake to the HVAC unit, is a folded paper element pollen filter which should be renewed at intervals specified in the Maintenance Schedule. An access panel beneath the front body hatch is provided to allow filter replacement by simply pulling out the old element and pressing in the new.

### Engine Bay Ventilation

Various intake and outlet vents are provided in the rear body to allow ventilation and cooling of the engine bay.

- Intake vents ahead of the rear wheelarches provide ambient air for the engine air intake, and for engine bay cooling.
- Outlet grilles around the top of the tailgate panel exhaust hot air from around the catalytic converter at the front of the engine bay.
- An outlet grille at the base of the tailgate glass, and to either side, exhaust hot air from around the catalytic converter at the rear of the engine bay.

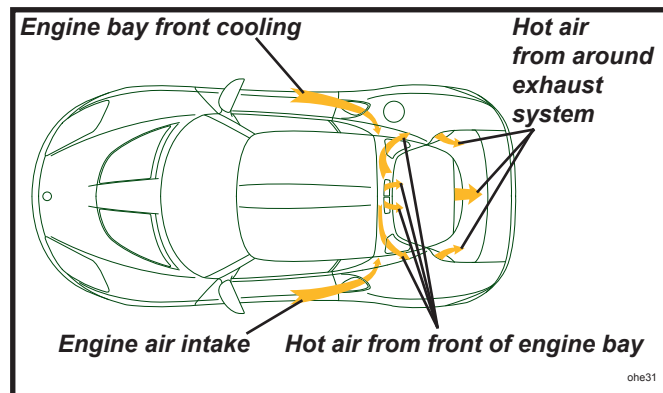

### PN.3 - COOLING FANS & RE-CIRCULATION PUMP

The two cooling fans are fitted on the top side of the radiator/condenser package, and the coolant re-circulation pump is mounted at the LH side of the engine bay, beneath the air cleaner. Both the fans and pump are controlled by the engine management ECU using data provided by the engine coolant temperature sensor and the a.c. trinary switch mounted in the refrigerant line between receiver-drier and evaporator.

### Cooling Fans

The cooling fans are switched as a pair, and will operate at half speed (connected in series) when coolant temperature reaches 98°C on rise (94°C with a.c. on), and switch off at 96°C on fall (92°C with a.c. on). If coolant temperature rises to 105°C (96°C with a.c. on), the fans will switch to full speed (connected in parallel), reverting to half speed on fall at 98°C (94°C with a.c. on).

Note that the temperatures displayed on the instrument panel may differ from the programmed values described above due to instrument damping lag.

The fans are also activated by signals received from the trinary switch; the fans will run at low speed for pressures between 13 - 18 bar, and at high speed for pressures over 18 bar.

Certain types of ECU detected engine fault will also cause the fans to be activated as an engine protection measure. If the ECU receives a coolant temperature sensor signal voltage outside of the acceptable range, a default setting equating to 60°C will be substituted, and the cooling fans will run at half speed.



## Re-circulation Pump

A coolant re-circulation electric pump is mounted beneath the air cleaner, and is plumbed into the heater supply line. When energised, the pump circulates coolant through the heater system, drawing coolant from the back of the cylinder head, and pumping it through the heater matrix and back to the engine.

## Heat Soak

After ignition switch off, the ECU remains live for a minimum period of 1 minute for coolant temperatures below 75°C (at time of switch off), extending progressively to a maximum period of 10 minutes for temperatures over 90°C. If, during this period, the coolant temperature exceeds 110°C, the re-circ. pump will be activated and will run for a maximum period of 6 minutes, or until the coolant temperature falls to 50°C.

If, during the ECU live period the coolant temperature rises to 120°C, the cooling fans will run at slow speed in addition to the re-circ. pump, for a maximum period of 2 minutes, or until the temperature falls to 70°C.

## PN.4 - REFRIGERANT HANDLING

The system is charged with 0.625 kg of refrigerant HFC R134a, and the following precautions **MUST ALWAYS BE OBSERVED**.

1. On no account should refrigerant ever be discharged to atmosphere - use a refrigerant recovery/recycling station in accordance with the manufacturer's instructions.
2. Standard R134a 'quick fit' connectors are provided in the compressor suction and discharge pipes at the right hand front of the engine bay;
  - the low pressure vapour line port is fitted in the pipe between the evaporator and compressor.
  - the high pressure liquid line port is fitted in the pipe between the compressor and condenser.
3. Heavy concentrations of refrigerant vapour can produce toxic gas if exposed to a naked flame. The gas can also attack metal.
4. Refrigerant drums must never be left open - always ensure the caps are securely fitted.
5. Never transport drums of refrigerant in the passenger compartment of a car.
6. Never expose refrigerant drums to high temperature.
7. Never weld or use a steam cleaner in close proximity to any part of the air conditioning system.
8. Never expose the eyes to vapourised or liquid refrigerant - ALWAYS wear safety goggles and gloves when handling refrigerant.

## PN.5 - REFRIGERANT PIPEWORK PRECAUTIONS

The following precautions must be observed when carrying out any work on the refrigerant pipework: Before disconnecting any refrigerant pipework, the refrigerant must first be recovered using suitable equipment connected to the service valves located at the rear of the right hand front wheelarch, behind the wheelarch liner. Ensure that the equipment is suitable for R134a.

1. All replacement components and flexible end connections are sealed when new, and should only be opened IMMEDIATELY PRIOR TO FITTING, AND AT ROOM TEMPERATURE, to prevent condensation of any moisture which may enter when the sealing is removed.
2. Pipes, flexible end connections and components, must be capped immediately they are opened to prevent the ingress of moisture and/or dirt.
3. The receiver-drier should be the LAST component to be connected, to ensure optimum dehydration and maximum moisture protection of the system.



Refrigerant Pipework Fixing Torques

Key	Description	Qty	Thread	Pitch	Torque
1	Compressor to engine	4	M8		25 Nm
2	A.C. hoses to compressor	2	M6		9 Nm
3	Sill pipe to comp. hose, high pressure	1	3/4 - 16 UNF	1.6	25-30 Nm
4	Sill pipe to comp. hose, low pressure	1	1 1/16 - 14 UNS	1.8	35-40 Nm
5	Sill pipe to condenser pipe	1	3/4 - 16 UNF	1.6	25-30 Nm
6	Receiver-drier connections	2	5/8 - 18 UNF	1.4	25-30 Nm
7	Evaporator pipe to receiver-drier	1	5/8 - 18 UNF	1.4	20-25 Nm
8	Trinary switch to pipe	1	3/8 - 24 UNF		10-13 Nm
9	Clamp plate, pipes to cond & exp valve	1	M6	1.0	9 Nm
10	Clamp plate, expansion valve to evap	1	M5	0.8	6 Nm
11	Evaporator to sill pipe	1	1 1/16 - 14 UNS	1.8	35-40 Nm

# Use refrigeration oil only, smear on "O" rings and threads prior to assembly  
 (Gloves should be worn when handling refrigeration oil - see data sheet)

Refrigerant Pipework 'O' Rings

Key	Description	Diameter	Part Number
A	Suction line to compressor. Condenser connections	16 mm	A120P6002H
B	High pressure line to compressor	13 mm	A120P6001H
C	Suction pipe to sill pipe and expansion valve	19 mm	A082P6081F
D	High pressure line to sill pipe	12 mm	A082P6079F
E	Receiver-drier connections and expansion valve inlet	9 mm	A082P6078F

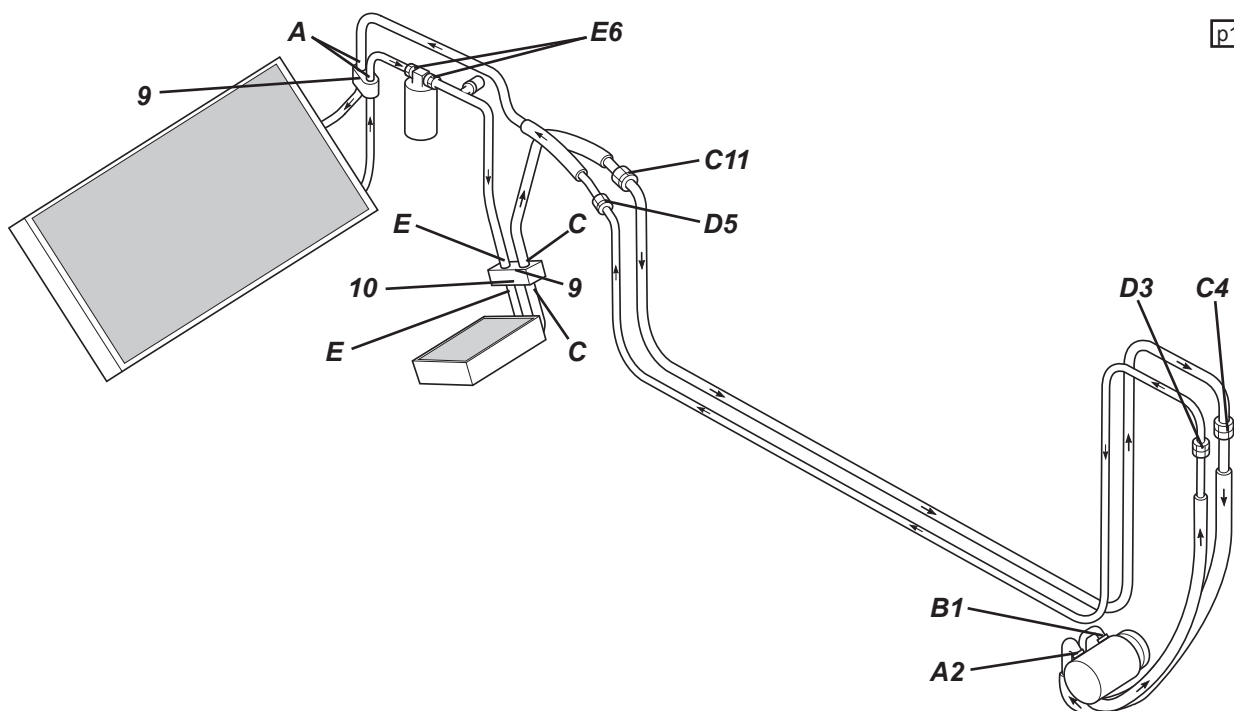





4. All joints should be coated with refrigeration oil before making any connections, to aid seating.
5. Great care must be taken to prevent damage to the pipe fittings and connections, since due to the high pressures involved, a leak can be caused by the slightest imperfection. Always use two spanners of the correct size when releasing or tightening any pipe joint so that the fixed part of the union may be prevented from twisting and damaging the component. This is especially important with the aluminium condenser.
6. All pipes and hoses must be free from any kinking. The efficiency of the system can be impaired by a single kink, or restriction. Flexible hoses should not be bent to a radius which is less than ten times the diameter of the hose.

## PN.6 - REFRIGERANT OIL

The internal working parts of the compressor are lubricated by refrigerant oil. This is a special type of oil which has an affinity with the refrigerant, such that a proportion of the oil circulates with the refrigerant, around the whole system. Under normal operating conditions, the oil never needs changing or replenishing, and if the correct procedure for system depressurisation and re-charging is followed, minimal oil will be lost from the system during these operations. If, however, the system suffers a major leak or sudden de-pressurisation, most of the oil held in suspension will be lost as the refrigerant escapes, necessitating the addition of a specified quantity of oil to the compressor on re-assembly (see section PN.7).

If a refrigeration component is to be replaced, the removed item will contain a certain amount of oil, and a corresponding amount of new oil must be added to the system on re-assembly:

Condenser;	30 cm <sup>3</sup>
Evaporator;	30 cm <sup>3</sup>
Any major pipe or hose;	10 cm <sup>3</sup>
Receiver-drier;	30 cm <sup>3</sup>

### Approved Oils

Use only Denso ND-OIL 8 low viscosity (ISO46) PAG oil or equivalent (Sanden SP10; Four Seasons 59007).

Refrigerant oil absorbs water and should not be exposed to the atmosphere for any longer than is strictly necessary to perform the operation. Never return decanted oil back into the storage container.

## PN.7 - COMPRESSOR

The a.c. compressor is mounted at the left hand front of the crankcase, and is driven from the crankshaft, together with the alternator, PAS pump and water pump, by a multi-rib, serpentine, synthetic belt. A maintenance free belt tensioner takes the form of an idler pulley mounted on a sprung eccentric hub, which mechanism applies pressure to the smooth, back side of the belt between the crankshaft and water pump, and provides a generous belt wrap around the crankshaft pulley.

The belt itself should be inspected for condition at each service interval, and if it exhibits any evidence of physical damage, cracking, fraying, perishing, abrasion, contamination or any other deterioration, it should be replaced. In the case of oil or coolant contamination, the cause must be identified and rectified, and each of the pulleys must be thoroughly degreased before the new belt is fitted.

### **Compressor Removal**

1. Remove the RHF wheelarch liner and recover the refrigerant using equipment connected to the service ports at the rear of the wheelarch.
2. Remove the driver's seat and cabin rear bulkhead trim. Remove the bulkhead access panel.
3. Remove the RHR wheel and wheelarch liner. Using a hexagonal 14mm socket applied to the auxiliary belt tensioner bolt, relieve the tension on the auxiliary drive belt by turning counterclockwise, and insert a 5 mm locking pin in the hole provided in the tensioner hub.



4. Release the clamp plate securing each of the pipes to the compressor and immediately cap the pipes and compressor ports to prevent ingress of dirt and moisture. Secure the two pipe/hoses aside.
5. Disconnect the two compressor electrical harness plugs.
6. Remove the four bolts securing the compressor to the engine, disengage the drive belt and withdraw the unit through the bulkhead aperture. Retain the compressor for oil quantity measurement if a new unit is to be fitted.

*Illustration TBA*

### Oil Quantity Adjustment Prior to Compressor Refitment

#### *Refitting Existing Compressor*

- i) If the existing compressor is to be refitted after normal refrigerant recovery has been performed, a quantity of oil equivalent to that recovered must be added to that already held in the compressor.
- ii) If the system has suffered a rapid discharge, caused for example by accident damage, most of the refrigerant oil will have been lost. Drain the remaining oil from the compressor by removing the drain plug and rotating the clutch plate. Add 150 cm<sup>3</sup> of new refrigerant oil (see above) to the compressor before refitment.

#### *Fitting New Compressor*

New compressors are sealed and pressurised with nitrogen gas. The sealing caps should be removed only immediately prior to compressor fitment, at which time the gas pressure should be heard to escape as a cap is slowly released. New compressors are supplied with an oil fill of 150 cm<sup>3</sup>.

- iii) If normal refrigerant recovery has been performed, the new compressor oil should be drained off, and the required oil quantity in the new compressor calculated and added:
  - Drain and measure the oil quantity in the **OLD** compressor by removing the drain plug and rotating the clutch plate. Quantity = X cm<sup>3</sup>
  - Oil quantity to be added to new compressor = X + 10 cm<sup>3</sup>
- iv) If the system has suffered a rapid discharge, caused for example by accident damage, most of the refrigerant oil will have been lost. In this case, fit the new compressor as supplied with its 150 cm<sup>3</sup> oil charge.



## Compressor Fitment

1. Fit the compressor to the engine and secure with the three M8 bolts; Tighten to 25 Nm (18 lbf.ft).
2. Using new 'O' rings lubricated with mineral refrigerant oil, fit the two refrigerant pipes to the compressor and tighten each clamp plate screw to 8 Nm.
3. Connect the compressor clutch harness.
4. Fit the auxiliary belt around the pulleys ensuring correct engagement of the ribs. Apply a counterclockwise torque to the auxiliary belt tensioner and remove the locking pin.
5. Recharge the system with R134a refrigerant.

## PN.8 - CONDENSER

The a.c. condenser, engine cooling radiator and cooling fans (in front to back order), are secured together as a package and mounted between the front subframe longerons leaning forwards at an angle of 45°. The package is flexibly mounted via grommets and spigots off the engine radiator, with the condenser rigidly fixed to the front of the radiator by 4 setscrews. The inlet pipe to the top section of the divided RH tank and the outlet pipe from the lower section of the RH tank extend to a joint plate accessible from above.

Removal of the condenser from below is possible without disturbing the engine radiator, and is facilitated by removal of the front clamshell, but is also possible with this panel *in situ*, using access provided by the headlamp apertures.

## To Remove Condenser

1. Remove the RHF wheelarch liner and recover the refrigerant using equipment connected to the service ports at the rear of the wheelarch.
3. Remove the front undertray and both headlamp assemblies (see sub-section BV.4).
4. Remove the radiator air intake duct lower section:
  - Release the headlamp powerwash hose from its 'P' clips
  - Remove both horns
  - Release the ambient temperature sensor from the RH side
  - Remove the 2 fixings securing the condenser to the radiator lower mounting brackets
  - Remove the 2 edge clips at each side securing the lower duct to the upper duct, and withdraw the lower section.
5. From the RH headlamp aperture, release the clamp plate securing the refrigerant pipes connection.
6. From each headlamp aperture, release the screw securing the top of the condenser to the radiator bracket.
7. At each side, release the single screw securing the bottom of the condenser to the radiator bracket, and withdraw the condenser.
8. Refit in reverse order to removal.
  - If a new condenser is fitted, add 30 cm<sup>3</sup> of approved refrigerant oil to the system.
  - Use new 'O' rings on the pipe connections, and lubricate with refrigerant oil.
  - Recharge the system with 0.625 kg of R134a.



## PN.9 - RECEIVER-DRIER

If the system has been open to atmosphere for any length of time, e.g. following accident damage or a burst hose or damaged component, the receiver-drier unit must be renewed, and should be the last component to be fitted, and uncapped only immediately prior to connection and recharging.

The receiver-drier is clamped to a mounting bracket fixed to the outside face of the front subframe RH longeron, ahead of the front wheel, and is accessible from beneath with the front undertray removed. If the receiver-drier is to be replaced, the refrigerant must first be recovered using suitable equipment connected to the service ports at the rear of the RHF wheelarch.

- Cap all pipes and ports immediately after disconnection to prevent the ingress of dirt and moisture.
- When reconnecting the pipes, use new 'O' rings coated in an approved refrigerant oil, and tighten to 25 - 30 Nm.
- If a new receiver-drier is fitted, add 30 cm<sup>3</sup> of approved refrigerant oil to the system.
- Recharge the system with 0.625 kg of R134a.

## PN.10 - HEATER/EVAPORATOR/FAN (HVAC) UNIT

The HVAC unit comprises left and right hand plastic mouldings sandwiched together and containing a pair of blower fans supplied from two intake sources, an a.c. evaporator, a heater matrix, and two electrically controlled flaps; one for the fresh air intake and one for the heater matrix. The complete HVAC unit is mounted between the chassis front bulkhead and subframe cross-member, with the steering rack beneath, and the radiator air outlet duct ahead.

### **To Remove HVAC Unit**

1. Remove the front undertray, front clamshell, radiator air outlet ducts and HVAC air inlet duct.
2. Remove the wiper motor mechanism from the windscreen surround.
3. Recover the refrigerant.
4. Remove the HVAC pollen filter intake moulding.
5. Unplug the fan harness connector block, and disconnect the heater flap and air inlet flap actuators.
6. Release the a.c. pipes clamp plate from the expansion valve, release the outlet pipe 'P' clip and secure the pipe aside, with both pipe and expansion valve port capped. Remove the pipe between receiver-drier and expansion valve, and cap all pipe ends and ports.
7. Remove the subframe crossmember. Remove:
  - 2 bolts securing the top of the HVAC unit to the subframe crossmember;
  - 2 bolts each side to top of longerons;
  - 2 Torx head screws each side to top of longerons;
  - 4 bolts each side securing the crossmember wall to the inboard side of the longeron;
  - 3 bolts securing lower edge of wall to subframe lower crossmember.Withdraw the crossmember/wall assembly.
8. From beneath, release the single bolt securing the HVAC unit to the chassis bulkhead, and the two bolts joining the fan housing bracket to the lower crossmember bracket.
9. Withdraw the HVAC unit.

The expansion valve is fitted onto the evaporator inlet and outlet pipes, and its removal requires disassembly of the HVAC unit. Determine the availability of the valve before embarking on such a task.

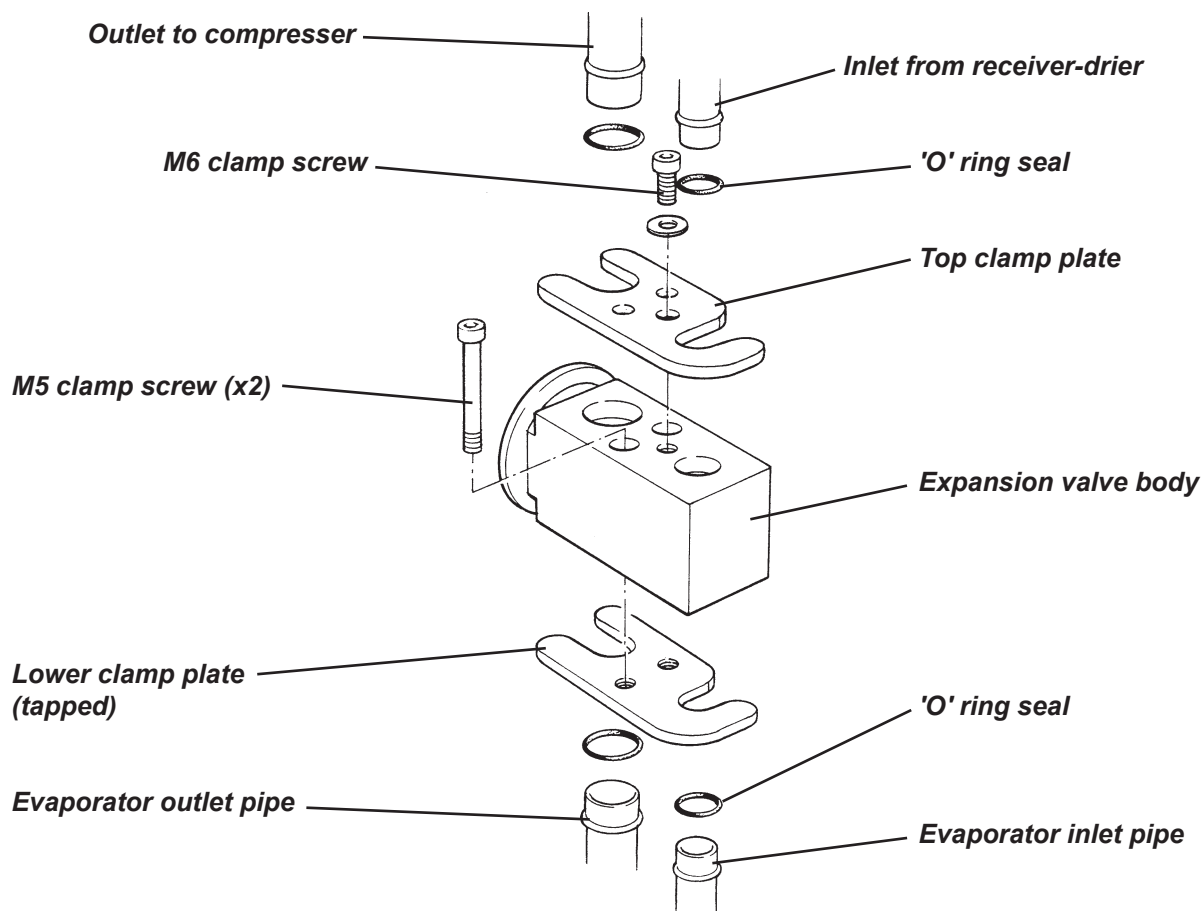

Refit the HVAC unit in reverse order to removal:

- If a new evaporator is fitted, add 30 cm<sup>3</sup> of approved refrigerant oil to the system.
- Use new 'O' rings on the pipe connections, and lubricate with refrigerant oil.
- Recharge the system with 0.625 kg of R134a.

#### PN.11 - AIR DISTRIBUTION UNIT (ADU)

The airflow distribution unit is mounted on top of the chassis scuttle, sandwiched between the underside of the fascia top/demist duct and the chassis. The unit comprises several plastic mouldings bonded and rivetted together to contain the rotary distribution drum which controls the airflow to the windscreen, face level vents, and footwells. The stepper motor for the drum is mounted on the left hand side of the unit.

#### **To Remove the Air Distribution Unit**

1. Remove the main fascia panel (see sub-section VE.8).
2. Remove the footwell duct between the side of the ADU and the passenger side scuttle aperture, by prising away from its double sided tape.
3. Remove the 2 bolts securing the ADU integral rear bracket to the scuttle.
4. From within the footwell, release the single bolt within the scuttle top central reinforcement channel.
5. Withdraw the ADU and disconnect the drum actuator harness plug.



## PN.12 - REFRIGERANT PIPES

The main feed and return (high pressure liquid and low pressure suction) lines between the compressor, condenser and expansion valve, take the form of aluminium pipes clamped along the outside of the chassis RH siderail, such that removal of the body side panel is required for access to the pipes. Replacement of the pipes is unlikely to be necessary other than as a result of accident damage, in which case the body sill will be replaced in accordance with Service Notes sub-section BS.9.



CLUTCH

SECTION QJ

	<u>Sub-Section</u>	<u>Page</u>
General Description	QJ.1	3
Clutch Pedal	QJ.2	3
Hydraulic Release System	QJ.3	3
Clutch Assembly	QJ.4	5



GENERAL LAYOUT

*Illustration TBA*





## QJ.1 - GENERAL DESCRIPTION

The Lotus Evora uses a CMS C500 cast iron flywheel bolted to the rear end of the engine crankshaft, secured with 8 bolts and located by a dowel pin. Sandwiched between the flywheel and crankshaft is a steel plate carrying the starter ring gear, and also secured to the periphery of the flywheel with 6 screws.

The driving surfaces of the clutch assembly comprise the rear face of the flywheel, and a corresponding surface on a pressure plate carried by the spring diaphragm clutch cover which is bolted to the periphery of the flywheel. The driven element, constitutes a single, dry, double sided friction plate, splined to the gearbox input shaft, and sandwiched between the flywheel and pressure plate. The diaphragm spring between the clutch cover and pressure plate serves to clamp the friction plate between the pressure plate and flywheel and provide the drive connection between engine and gearbox. The gearbox input shaft, on which the friction plate is free to slide axially, is 'overhung' from the gearbox, with no spigot bearing in the rear end of the crankshaft.

The hydraulic clutch release mechanism uses a master cylinder fixed to the pedal box and operated by the clutch pedal, and a slave cylinder bolted to the left hand side of the clutch housing operating a release fork pivoted on a ball pin inside the housing to apply an axial thrust to the release bearing. The release bearing surrounds the gearbox input shaft and transmits the thrust via a ball bearing race to the inner ends of the diaphragm spring. This action releases the clamping action of the spring outer rim, serving to disengage the drive.

No routine adjustment of the clutch or release mechanism is required. The clutch slave cylinder is self adjusting, with the 'rest' position of the piston dependent on the thickness, or degree of wear, of the friction plate. As wear of the friction plate takes place, and its thickness is reduced, the slave cylinder piston is pushed progressively further back on the return stroke with a corresponding rise in the reservoir fluid level.

## QJ.2 - CLUTCH PEDAL

The clutch pedal is fabricated from steel plate, and features synthetic 'top hat' bushes for maintenance free articulation on the steel pivot shaft, and a serrated alloy footpad. A hollow steel pivot shaft serving the brake and clutch pedals is bolted to a steel mounting plate, itself bolted to the inside of the pedal box.

The clutch pedal is equipped with an overcentre assist coil spring linkage, in order to reduce the pedal effort required to maintain full disengagement. A potentiometer is also fitted in order to provide data for Cruise Control operation, and for the start inhibit function on Canadian market cars.

The master cylinder pushrod is captive in the end of the master cylinder, and uses an integral clevis to connect to the pedal and control the pedal up position as the master cylinder 'tops' out. A downstop buffer is provided on the pedal box flange.

## QJ.3 - HYDRAULIC RELEASE SYSTEM

### **Master Cylinder**

The clutch master cylinder is mounted on the pedal box, and is accessible with the front clamshell removed. The cylinder is not equipped with its own fluid reservoir, but instead is linked via hose to the adjacent brake fluid reservoir. There is no provision for any servicing of the master cylinder, and if found to be faulty, the unit should be replaced.

### **WARNING**

**Do not attempt to bleed the clutch hydraulic system when the catalytic converter is hot - spilled hydraulic fluid could initiate a fire. Wait until the engine and converter is cool to the touch.**

*To replace the master cylinder:*

- Remove the front clamshell (see sub-section BV.6).
- Clean the master cylinder and surrounding area with methylated spirit. **Do not use petrol or paraffin.**
- Take all necessary precautions to guard against contamination of painted surfaces with brake fluid.
- Disconnect and immediately plug and cap the hose connection to the fluid reservoir, and the output pipe connection.
- From inside the footwell, remove the clevis pin connecting the pushrod to the pedal. Remove the two bolts securing the cylinder to the pedal box and withdraw the cylinder from above.



*Illustration TBA*

- To refit, reverse the removal procedure. Tighten the outlet pipe connection to 20 - 24 Nm, and the cylinder to pedal box fixings to 28 Nm. Bleed the hydraulic system of air, using the bleed nipple provided on the slave cylinder.

### **Slave Cylinder**

The slave cylinder is secured to the left hand side of the clutch housing by two M8 fixings into tapped holes. The cylinder is protected from radiated heat from the front catalytic converter by an aluminium heat shield, part of which may be bent back to allow improved access to the slave cylinder bleed nipple.

### **WARNING**

**Do not attempt to bleed the clutch hydraulic system when the catalytic converter is hot - spilled hydraulic fluid could initiate a fire. Wait until the engine and converter is cool to the touch.**

To remove the cylinder, first disconnect the pipe union and immediately seal the open end of the pipe and the cylinder port. Release the two fixing bolts and withdraw the cylinder. If necessary, remove the cylinder end protective rubber boot and pushrod, and use compressed air in the hydraulic port to expel the piston assembly.

To re-assemble, coat the seals with lithium soap base glycol grease before inserting into the cylinder, and then fitting the pushrod and boot. Secure with the two M8 bolts tightened to 12 Nm (9 lbf.ft), connect the hydraulic line (15 Nm {11 lbf.ft}), and bleed the system of air, tightening the bleed nipple to 5 Nm (45 lbf.in). Finally, ensure that the heat shield is returned to its original shape in order adequately to protect the slave cylinder and hydraulic line.

### **Hydraulic Pipe**

A 2-part rigid steel pipe is used to convey the hydraulic fluid from the master cylinder to the left hand front corner of the engine bay. The pipe is routed down the LH 'A' post to run along the outside of the chassis LH main siderail, within the composite sill member, and is supported, together with other pipes and hoses in foam blocks. A flexible hose is used to connect the rear end of the chassis pipe to a short rigid pipe on the transmission, which connects to the slave cylinder.



## QJ.4 - CLUTCH ASSEMBLY

The clutch assembly comprises the friction plate, clutch cover assembly (pressure plate/diaphragm spring/cover) and release bearing. For access to the clutch assembly, the complete power unit must first be removed from the chassis (see sub-section EJ.5).

To separate the transmission from the engine, see sub-section FL.5.

The clutch cover is secured to the flywheel by 6 x M8 bolts and located by 3 dowels. Unless the cover is to be renewed, first match mark the cover to the flywheel before gradually loosening the 6 bolts in an even pattern, to release the clamp load without distorting the clutch cover. Finally, remove the bolts and withdraw the cover from the flywheel dowels making provision to capture the friction plate which will also be released.

### Inspection & Replacement

- Clutch cover:** Check the surface of the pressure plate for excessive scoring or discolouration through overheating. Check the fingers of the diaphragm spring for excessive wear at the release bearing contact surface and for even height. If the cover is accidentally dropped, the setting or balance of the assembly could be disturbed; replacement of the cover is recommended.

On re-assembly, use a universal type of centralising mandrel to position the centre plate (ensuring it is the correct way round - refer to markings) whilst the clutch cover is fitted. Apply a suitable thread locking compound to the cover fixing bolts before locating the cover on the flywheel dowels and progressively tightening the bolts in a diagonal sequence to avoid distorting the cover. Torque to 20 Nm.
- Friction plate:** Check the cush drive springs for breakage or cracking of the hub. Examine the condition of the friction material for signs of oil contamination, scorching, or any other damage. Measure the depth of material on both sides of the plate from the friction surface to the head of the rivets; Minimum service depth = 0.3 mm.

If any of the above inspections are failed, or if addressing symptoms of clutch judder, renew the friction plate.
- Release bearing & fork:** Unclip the release bearing from the fork, and check the bearing for discernible play, noise or rough feeling, and renew if there is any doubt. Check the arm for undue wear on any of the contact surfaces and for cracks. Check the release fork pivot ball.
- Flywheel:** Check the friction surface of the flywheel for excessive scoring or discolouration through overheating. Using a dial test indicator, measure the axial run-out at the centre of the flywheel friction surface. Maximum runout: 0.15 mm.

If necessary, renew the flywheel:

  - Lock the flywheel ring gear and progressively release the eight bolts securing the flywheel to the crankshaft and withdraw, noting the loose spacer ring between the ring gear plate and the crankshaft flange.
  - If necessary, release the six bolts securing the ring gear to the front of the flywheel. When re-fitting, ensure that the ring gear plate swages face towards the flywheel. Use an appropriate alignment mandrel to ensure concentricity of the ring gear to the flywheel before tightening the 6 securing bolts to 30 Nm.
  - When re-mounting the assembly to the crankshaft, ensure the spacer ring is fitted between the ring gear and crankshaft, with the dimple on the spacer locating in the crankshaft flange dowel hole.
  - Ensure scrupulous cleanliness of all mating surfaces before locating the flywheel onto the crankshaft and fitting the 8 bolts to which Permabond A130 (A912E7033) has been applied to the threads.
  - Progressively tighten the bolts in a diagonal sequence, locking the ring gear before finally torque tightening to 65 Nm.

### Re-assembly

Apply sparing quantities of Molybdenum Disulphide (MoS<sub>2</sub>) grease to the contact points of the release fork fingers, pivot socket, and pushrod socket. Also apply sparingly to the input shaft splines, or use the special grease provided with a new friction plate. Fit the fork through the housing aperture and grommet, locate on the pivot ball, slide the release bearing over the input shaft and clip to the release fork arms.

Fit the transmission assembly to the engine (see sub-section FL.5), and refit the power unit (sub-section EJ.5).



TECHNICAL DATA - ENGINE

SECTION TDT

	<u>Page</u>
General .....	2
Cylinder Block .....	2
Cylinder Head .....	2
Valves & Springs .....	3
Camshafts .....	3
Pistons .....	3
Crankshaft .....	3
Oil Pump .....	3
Coolant Thermostat .....	4

**GENERAL**

Type designation	2GR-FE
Configuration	V6
Capacity	3456 cm <sup>3</sup> (210.9 in <sup>3</sup> )
Bore	94.0 mm (3.70 in <sup>3</sup> )
Stroke	83.0 mm (3.27 in <sup>3</sup> )
Valve configuration	4 VPC in pentroof chamber
Camshaft configuration	DOHC per bank
Camshaft drive	Single chain drive to both inlet camshafts. Secondary chain linking each inlet camshaft to its neighbouring exhaust camshaft. All 4 camshafts use hydraulically activated variable timing sprocket hubs under ECU control
Valve operation	Finger followers with hydraulic pivot posts Siamese ports
Compression ratio	10.8:1
Compression pressure	- new minimum 1,400 kPa (14 kgf/cm <sup>2</sup> , 199 psi) - service minimum 980 kPa (10.0 kgf/cm <sup>2</sup> , 142 psi) - cyl/cyl max. variance 100 kPa (1.0 kgf/cm <sup>2</sup> , 15 psi)
Firing order	1,2,3,4,5,6
Spark plugs	Denso FK20HR11 (Iridium)
Spark plug gap	1.0 - 1.1 mm (0.040 - 0.045 in)
Engine management	Lotus T4e controller
Ignition system	Direct ignition using individual plug top coils
Fuel system	Port injection. Synchronous and non-synchronous operation Hot wire airflow sensor
Fuel requirement	Minimum 95 RON
Intake system	Single throttle valve 2 stage intake tract length
Maximum continuous engine speed	- std 6,600 rpm - Sport mode 7,000 rpm
Maximum transient engine speed	- std 6,800 rpm - Sport mode 7,200 rpm
Normal warm idle speed	- a.c. off 640 rpm - a.c. on 690 rpm
Net power (ECE 85)	206 kW @ 6,400 rpm
Net torque (ECE 85)	350 Nm @ 4,600 rpm
Exhaust emissions (ECE 83.05)	- CO 0.169 g/km - HC 0.049 g/km - NOx 0.016 g/km - HC + NOx 0.065 g/km - CO <sub>2</sub> - Urban 293 g/km - Extra urban 154 g/km - Combined 205 g/km

**CYLINDER BLOCK**

Material	Aluminium alloy with 'cast in' cast iron cylinder liners
Configuration	60°V, right hand bank offset 36.6mm forward RH bank; cylinders 1,2,3 from front LH bank; cylinders 4,5,6 from front
Bore diameter	- std 94.000 to 94.012 mm (3.7008 to 3.7013 in.) - service limit 94.200 mm (3.7087 in.)
Deck face flatness tolerance	0.07 mm (0.0028 in.)

**CYLINDER HEAD**

Material		Aluminium alloy
Head face flatness tolerance		0.10 mm (0.004 in.)
Manifold face flatness tolerance		0.10 mm (0.004 in.)
Valve guide bore in head	- std	10.285 to 10.306 mm (0.4049 to 0.4057 in.)
	- 05mm o/s	10.335 to 10.356 mm (0.4069 to 0.4077 in.)
Valve guide standout	- inlet	9.1 to 9.9 mm (0.36 to 0.39 in.)
	- exhaust	9.3 to 9.7 mm (0.3661 to 0.3819 in.)
Maximum oil clearance	- inlet	0.08 mm (0.0031 in.)
	- exhaust	0.10 mm (0.0039 in.)

**VALVES & SPRINGS**

Valve stem diameter	- inlet	5.470 to 5.485 mm (0.2154 to 0.2159 in.)
	- exhaust	5.465 to 5.480 mm (0.2151 to 0.2157 in.)
Overall length	- inlet	- std 5.465 to 5.480 mm (0.2151 to 0.2157 in.)
		- min 105.35 mm (4.1476 in.)
	- exhaust	- std 110.40 mm (4.3464 in.)
		- min 109.90 mm (4.3268 in.)
Valve seat contact width	- inlet	1.1 to 1.5 mm (0.043 to 0.059 in.)
	- exhaust	1.2 to 1.6 mm (0.047 to 0.063 in.)
Valve head margin (thickness between head face and 45° face)	- std	1.00 mm (0.040 in.)
	- minimum	0.50 mm (0.020 in.)
Valve spring free length		45.46 mm (1.790 in.)

**CAMSHAFTS**

Endfloat	- std	0.08 to 0.13 mm (0.0031 to 0.0051 in.)
	- service limit	0.15 mm (0.006 in.)
Maximum oil clearance	- front journal	0.15 mm (0.006 in.)
	- except front	0.09 mm (0.0035 in.)

**PISTONS**

Diameter 10mm below pin centreline	- std	93.960 to 93.980 mm (3.6992 to 3.6999 in.)
	- minimum	93.830 mm (3.6941 in.)
Bore oil clearance	- std	0.020 to 0.052 mm (0.0007 to 0.0020 in.)
	- service limit	0.060 mm (0.0024 in.)
Gudgeon pin oil clearance	- std	0.001 to 0.007 mm (0.00004 to 0.0003 in.)
	- service limit	0.015 mm (0.0006 in.)

**CRANKSHAFT**

Main journal diameter		60.988 to 61.00 mm (2.4011 to 2.4016 in.)
Main journal max. runout		0.06 mm (0.0024 in.)
Main journal maximum taper and out-of-round		0.02 mm (0.0008 in.)
Crankpin diameter		52.992 to 53.000 mm (2.0863 to 2.0866 in.)
Crankpin maximum taper and out-of-round		0.02 mm (0.0008 in.)

**OIL PUMP**

Rotor tip clearance	- std	0.060 to 0.160 mm (0.0024 to 0.0063 in.)
	- service limit	0.16 mm (0.0063 in.)
Annulus to housing clearance	- std	0.250 to 0.325 mm (0.0098 to 0.0128 in.)
	- service limit	0.325 mm (0.0128 in.)
Rotor/annulus side clearance	- std	0.030 to 0.090 mm (0.0012 to 0.0035 in.)
	- service limit	0.090 mm (0.0035 in.)
Hot oil pressure	- idle	80 kPa (0.8 kgf/cm <sup>2</sup> , 11.6 psi)
	- 6,000 rpm	380 kPa (3.9 kgf/cm <sup>2</sup> , 55.5 psi)



COOLANT THERMOSTAT

Valve opening temperature  
Valve lift at 95°C

80 to 84°C (176 to 183°F)  
10 mm



TECHNICAL DATA - VEHICLE

SECTION TDU

	<u>Page</u>
Dimensions .....	2
Capacities .....	2
Wheels & Tyres .....	2
Front Suspension .....	3
Rear Suspension .....	3
Electrical .....	3
Transmission .....	4
Clutch .....	4
Brakes .....	4
Steering .....	4
Fuel Consumption .....	4





### DIMENSIONS

Overall length		4350 mm
Overall width	- excl. mirrors	1848 mm
	- incl. mirrors	1972 mm (approx.)
Overall height (unladen)		1229 mm
Wheelbase		2575 mm
Track	- front	1564 mm
	- rear	1557 mm
Ground clearance (mid-laden)		125 mm
Front overhang		1000 mm
Rear overhang		776 mm
Approach angle		11.5°
Departure angle		22°
Unladen weight	- total	1382 kg ) inc. full
	- front	526 kg ) fuel tank
	- rear	856 kg )
Max. weight	- total	1782 kg > incl.
	- front	659 kg > occupants
	- rear	1123 kg > & luggage
Trailer towing		Not permissible

### CAPACITIES

Engine oil	- dry	- with heat exchanger	7.1 litre
		- w/o heat exchanger	6.8 litre
	- refill inc. filter, with/w/o heat exchanger		6.1 litre
High/low dipstick mark difference			1.0 litre
Transmission oil			2.3 litre
Brake system hydraulic fluid			450 cc
Clutch system hydraulic fluid			130 cc
Fuel tank			60 litre
Coolant			17 litre
Refrigerant			0.625 kg

### WHEELS & TYRES

#### **Tyres** (normal use)

Type		Pirelli P-Zero
Size	- front	225/40 ZR18
	- rear	255/35 ZR19 96Y
Pressure (cold)	- front	2.3 bar (33.5 psi)
	- rear	2.5 bar (36 psi)

#### **Winter Tyres**

Type		Yokohama W.drive V902 'LTS'
Size	- front	215/40 R18
	- rear	245/35 R19
Pressure (cold)	- front	2.3 bar (33 lb/in <sup>2</sup> )
	- rear	2.5 bar (36 lb/in <sup>2</sup> )
Tyre studding		Not permitted
Tyre chains		RUD-matic DISC snow chains (Lotus part number A132G6004F), fitted only on the rear, and only on the approved winter tyres.

#### **Wheels**

Type	- std	Cast alloy, 10 spokes in pairs, 5-bolt fixing Silver or grey painted
	- optional	Forged alloy, 10 radial spokes, 5-bolt fixing Silver or grey painted



Size	- front	8.0J x 18H2
	- rear	9.5J x 19H2
Inset	- front	+ 52 mm
	- rear	+ 69 mm
Wheel bolt torque		105 Nm (77 lbf.ft)

## FRONT SUSPENSION

Type Independent. Upper and lower lightweight forged alloy wishbones; co-axial coil spring/telescopic damper unit; tubular anti-roll bar

### *Geometry*

Mid-laden ride height (2 x 75 kg occupants + full fuel tank)

- set car to this height before measuring geometry:	- front 125 mm below front end of chassis siderail
	- rear 147 mm below rear end of chassis siderail
Castor	+ 5.2°
- optimum	+ 5.0° to + 5.5°; max. side/side 0.3°
- tolerance range	
Camber	- 0.3°
- optimum	- 0.5° to - 0.2°; max. side/side 0.2°
- tolerance range	
Alignment	Zero
- optimum	0.5 mm toe-out, to 0.5mm toe-in overall
- tolerance range	
Steering axis inclination	9.4° nominal

## REAR SUSPENSION

Type Independent. Upper and lower lightweight forged alloy wishbones; co-axial coil spring/telescopic damper unit; tubular anti-roll bar

### *Geometry*

Mid-laden ride height (2 x 75 kg occupants + full fuel tank)

- set car to this height before measuring geometry:	- front 125 mm below front end of chassis siderail
	- rear 147 mm below rear end of chassis siderail
Camber	- 1.6°
- optimum	- 1.8° to - 1.5°; max. side/side 0.2°
- tolerance range	
Alignment	1.5 mm toe-in each side
- optimum	1.4 to 1.8 mm toe-in each side
- tolerance range	max. side/side 0.3 mm
Thrust angle	Zero
- optimum	0.05°
- tolerance	

## ELECTRICAL

### *Light Bulbs*

	<i>Wattage</i>	<i>Type</i>
Headlamps	35	D1S electronic igniter/burner unit
Rear turn indicators	21	P21W
Licence plate lamps	5	C5W
Interior lamp	5	W5W

Note that other lamps are likely to be long life LED type, serviced only by lamp replacement.

System voltage/polarity	12V negative earth
Alternator	100A
Battery (service replacement)	- type Varta L3B (T6)
	- rating 72 Ah



TRANSMISSION

Designation 6 speed manual type EA60  
Differential Open bevel gear

*Gear ratio table ('opt' refers to alternative ratio set)*

Gear	Internal ratio	Final drive	mph/1000rpm	km/h/1000rpm
1	3.54	3.78	5.6	9.1
2	1.91	3.78	10.4	16.7
3	1.22	3.78	16.3	26.3
3 opt	1.41	3.78	14.1	22.8
4	0.86	3.78	23.1	37.2
4 opt	1.09	3.78	18.2	29.4
5	0.79	3.24	29.4	47.3
5 opt	0.97	3.24	23.9	38.5
6	0.64	3.24	36.3	58.4
6 opt	0.86	3.24	27	43.5
Rev	3.83	3.24		

CLUTCH

Type Single dry plate. Diaphragm spring cover.  
Hydraulic release, self adjusting  
Friction plate diameter 228 mm  
Friction plate clamped thickness - new 8.0 mm  
Damper springs 4 off  
Hub material Sintered steel  
Clamp load - new 8350N

BRAKES

Brake discs Cast iron, curved vane ventilated, cross-drilled  
Rear discs incorporate parking drums  
Disc dimensions - front 350 x 32 mm  
- rear 332 x 26 mm. 185 mm drum  
Callipers A.P. Racing, aluminium alloy body, 4 pistons in  
opposed pairs. Common casting front/rear  
Piston size - front Leading; 38.1 mm. Trailing; 41.3 mm  
- rear Leading; 38.2 mm. Trailing; 36.0 mm  
Operation Tandem master cylinder with dual diaphragm  
vacuum servo and Bosch Anti-lock system  
Parking brake Cable operated drum brakes incorporated into rear  
discs

STEERING

Type Power assisted rack and pinion  
Turns, lock to lock 2.86  
Gear ratio 47mm rack movement/steering wheel revolution

FUEL CONSUMPTION

1999/100/EC - urban 12.4 l/100km  
- extra urban 6.5 l/100km  
- combined 8.7 l/100km



INTERIOR TRIM

SECTION VE

	<u>Sub-Section</u>	<u>Page</u>
General Description	VE.1	3
Door Trim Panel	VE.2	3
Door Trim Panel Components	VE.3	4
Door Sill Trim Panel	VE.4	4
Lower 'A' Post Trim Panel	VE.5	5
Centre Console	VE.6	5
Fascia Dash Panel	VE.7	5
Fascia Lower Panels	VE.8	6
Main Fascia Panel	VE.9	6
Steering Column Shroud	VE.10	6
Windscreen Pillar Trim Panels	VE.11	7
Rear Quarter Panels	VE.12	7
Rear Seat Backrest or Bulkhead Pad	VE.13	7
Rear Window Surround	VE.14	8
Roof Lining	VE.15	8



pl1405

**FASCIA STRUCTURE**

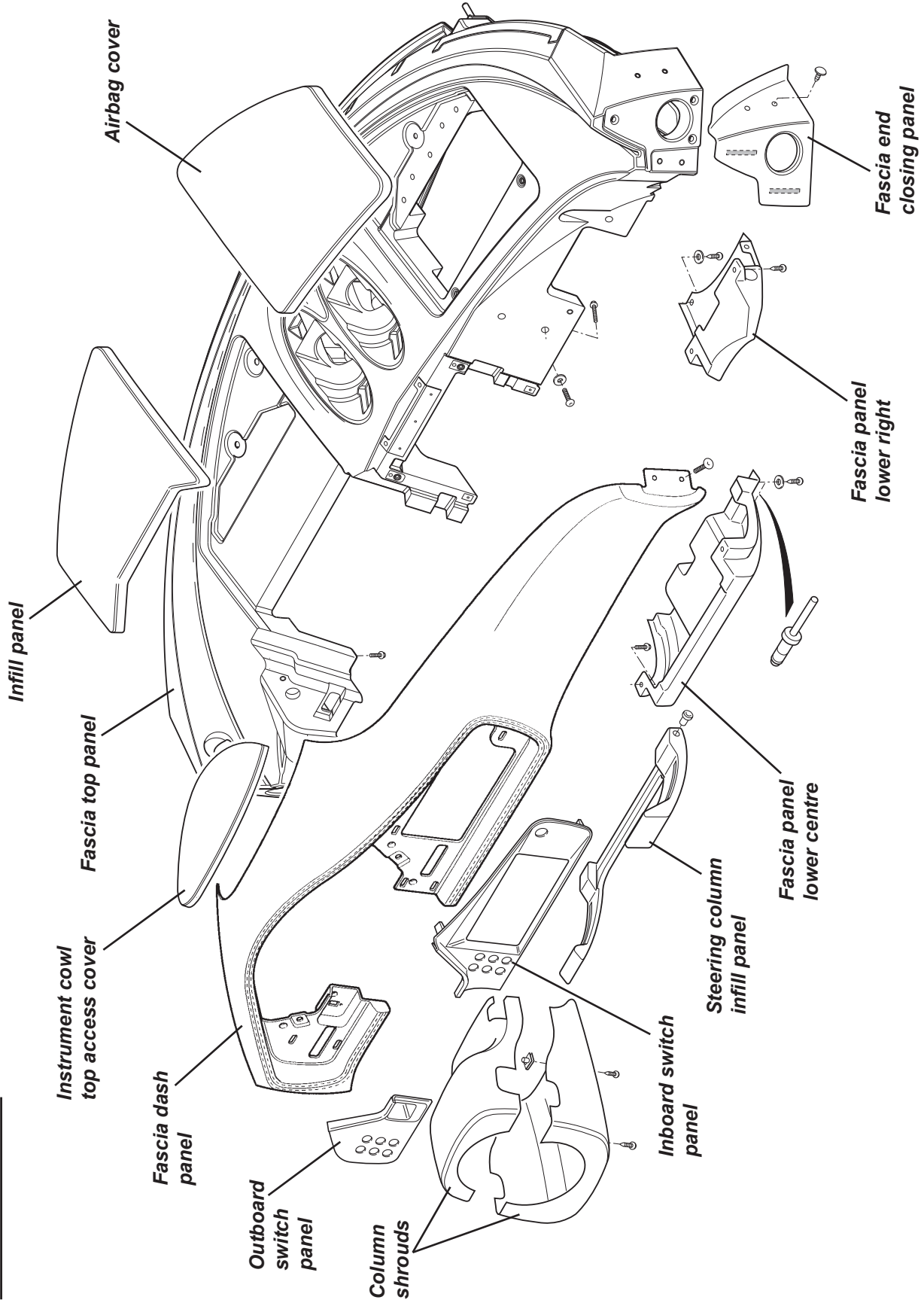



## VE.1 - GENERAL DESCRIPTION

Interior trim panels on the Evora are manufactured by one of three processes;

1. *Structural Reaction Injection Moulding (SRIM)*; using a polyurethane resin and glass reinforcement.  
Panels include:
  - Door trim panels;
  - Lower 'A' post trim panels;
  - Door sill trim panels;
  - Rear quarter trim panels;
  - Rear bulkhead trim panel;
  - Centre console;
  - Fascia panel lower centre;
  - Fascia panel lower left hand and right hand;
  - Fascia dash panel.
2. *Polyurethane Foam*;  
Panels include:
  - Fascia top panel;
  - Passenger airbag cover;
  - Driver's side fascia infill panel;
  - Glovebox lid;
  - Steering column cover.
3. *Reaction Transfer Compression (RTC) moulding*; using a polypropylene glass reinforced moulding to which is bonded a Nylon polypropylene fabric with a foam backing (visible surface) and a polypropylene foam lining (reverse side).  
Panels include:
  - Roof liner;
  - 'B' post upper trim panels;
  - 'A' pillar trim panels.

## VE.2 - DOOR TRIM PANEL

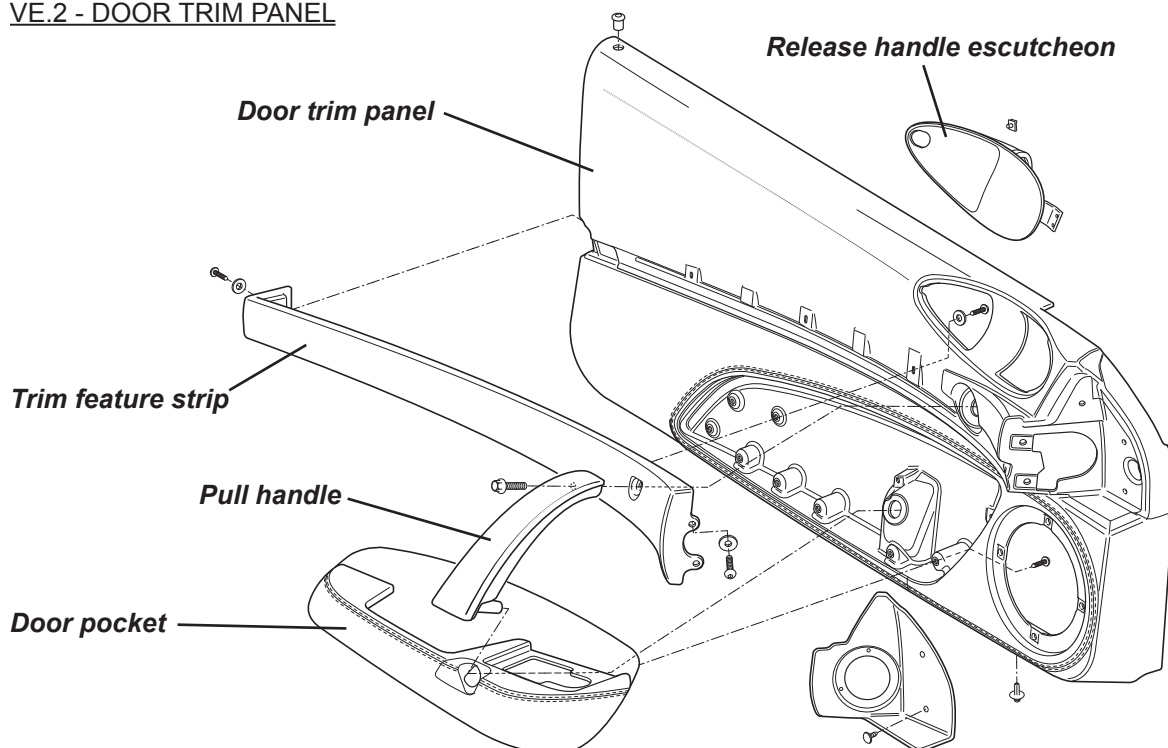

v22



The door trim panel is secured to the door shell by the door pull handle fixings, five screws along the bottom shutface, a single screw at the top front corner, and three location pegs along the top edge. Note that the door speaker grille is fixed to the door panel, but the speaker itself is mounted to the door shell.

### To remove/refit door trim panel

1. Prise out the window and mirror switches and unplug the harness connector.
2. Remove the door front top corner closing panel:
  - Prise out the two fir tree fasteners.
  - Remove the two screws in the flange of the air duct connector.Remove the single fixing screw securing the panel to the door shell.
3. Prise out the finisher plate from the door pull handle (4 spring clips), and remove the two fixings securing the handle and trim panel to the door.
4. Remove the five screws in the underside of the door securing the panel. Pull out the bottom of the door panel and lift the top edge location pegs from their slots in the door shell. Unhook the door release cable from the handle, and disconnect the door harness from the window/mirror switchgear and mood lighting strip.

Refit in reverse order to removal.

### VE.3 - DOOR TRIM PANEL COMPONENTS

#### Face level vent/release handle escutcheon

1. The face level vent itself may be pulled out of the escutcheon with the door panel *in situ*.
2. To remove the escutcheon, the door panel must be removed. Then from behind the panel, remove the blanking sticker on the air duct moulding to access the two screws securing the front of the escutcheon, and release another pair of screws in the door release handle bracket.

#### Door release handle

To remove the door release handle, remove the door trim panel and from behind the panel, release the four fixing screws.

#### Trim feature strip & mood lighting

The feature strip is secured by two fixings in the front shut face, two in the rear shut face and three screws along its length, all accessed from behind the panel. The mood lighting strip is secured to the door trim panel with double sided tape.

#### Door pocket

The door pocket comprises inner and outer parts both secured to the door trim panel from behind by 10 screws.

### VE.4 - DOOR SILL TRIM PANEL

The door sill trim panel is secured to the chassis side rail by two 'fir tree' buttons located at the rear lower edge. Prise out the buttons, and lift the rear of the panel to release the 'grip-lok' strips. Unhook the front end tongues from the lower 'A' post trim panel.

If necessary, remove the harness protection cover from the rear of the sill by prising out the 'fir tree' buttons on the lower edge, and pulling the panel from its double sided tape.



### VE.5 - LOWER 'A' POST TRIM PANEL

1. Remove the door sill trim panel (see VE.3).
2. Release the three screws securing the bottom edge to the chassis side rail, and the single screw at the outboard top corner to the scuttle beam.
3. Pull the panel from the 'grip-lok' strips on the footwell side wall.

### VE.6 - CENTRE CONSOLE

The centre console, which is constructed from separate right and left hand sides, and a top panel, extends from the base of the fascia to the rear seats/stowage compartment, and surrounds the gear and parking brake levers. To remove the console:

1. Remove the parking brake lever sleeve after loosening the retaining grub screw.
2. Prise the Lotus badge from the gear lever knob, release the screw and withdraw the knob.
3. Release the armrest from its hinge by removing the two fixings beneath its rear end.
4. Remove the HVAC panel from the console by careful prising to release the 5 Tower-clip fasteners. Unplug the harness connectors, and lift the panel until the gaiter top clip can be released, and the panel fully withdrawn.
5. Release the two screws at the back of the gear lever aperture securing the park brake lever surround, unhook the rear end and withdraw the panel and gaiter over the lever.
6. Remove 3 screws within the front aperture securing the console top panel, and pull the rear part of the panel upwards to withdraw the two Tower clips.
7. Remove the 4 screws securing the top surfaces of the console sides together. Remove the 3 screws securing each of the side's lower rear flanges to the floor channel. Pull away the front end of each side panel to release the two spring steel clips.

### VE.7 - FASCIA DASH PANEL

The fascia dash panel reaches across the full width of the fascia and includes the instrument cowl/surround. The panel also mounts the instrument pack, switch panels and mood lighting strip. To remove the panel:

1. Remove the closing panel from each end of the fascia by prising out the two fir tree fasteners, and pulling the panel from its Griplock strips. At each end, release the two screws securing the dash panel to the fascia.
2. Remove the instrument cowl top access panel by lifting the forward end free from its Griplock strips, and unhook the rearward end. Unplug the harness connectors from the instrument panel.
3. From within the coin pocket outboard of the steering column, remove the blanking sticker and release the switch panel fixing screw. Carefully prise the outboard switch panel out with its two Tower clips. Unplug the switch harness connector.
4. Carefully prise out the inboard switch panel with its four Tower clips and unplug the switch harness connectors.
5. Release the four screws round the underside of the instrument panel (not the screws securing the instrument panel itself), fixing the dash panel to the fascia.





6. Open the glovebox, and from within, release the 4 hex. head screws securing the fascia panel finisher to the glovebox wall.
7. Withdraw the dash panel, and unplug the harness connectors to the mood lighting strip and glovebox light.

### VE.8 - FASCIA LOWER PANELS

The fascia lower panels comprise left, right and centre panels, plus the passenger's glovebox and driver's column infill panel, all of these linking the underside of the main fascia to the chassis scuttle beam. These panels should be removed before removal of the main fascia panel.

1. Driver's side fascia lower panel: Swing down the column infill panel by pulling the top edges to release the Griplock fastener strips. Remove the single screw securing the panel to the scuttle beam and the two screws to the underside of the fascia. Withdraw the panel from the location pin.
2. Passenger's side fascia lower panel: Open the glovebox fully by releasing the check cord and damper cord. Remove the single screw securing the panel to the scuttle beam and the two screws to the underside of the fascia.
3. Withdraw the column infill panel or glovebox from the location pin.
4. Central fascia lower panel: First remove the centre console (see section VE.5). Remove the two screws securing the centre fascia lower panel to the scuttle beam, and the two screws to the underside of the main fascia panel.

### VE.9 - MAIN FASCIA PANEL

The main fascia panel extends from the base of the windscreen to the scuttle beam, carries the dash panel and passenger airbag, and incorporates ducting to the demist vents. To remove the main fascia panel:

1. Remove the fascia dash panel (see VE.6).
2. Remove the fascia lower panels (see VE.7).
3. Unplug the passenger airbag connectors.
4. Remove the two screws securing the fascia to the rear face of the scuttle beam, beneath the passenger's airbag.
5. At each end, remove the single screw securing the fascia to the support bracket on the scuttle beam.
6. Draw the main fascia panel rearwards to disengage the three front edge spigot pins from their location holes in the windscreen frame.

### VE.10 - STEERING COLUMN SHROUD

The steering column shroud consists of upper and lower mouldings. The upper section is clipped to the lower, and should be prised off before releasing the three screws securing the lower section to the steering column.



## VE.11 - WINDSCREEN PILLAR TRIM PANELS

Each windscreen pillar trim panel is retained by a single 'fir tree' button at its lower end, and by 3 captive 'fir trees' along its length.

## VE.12 - REAR QUARTER PANELS

### **Rear window surround**

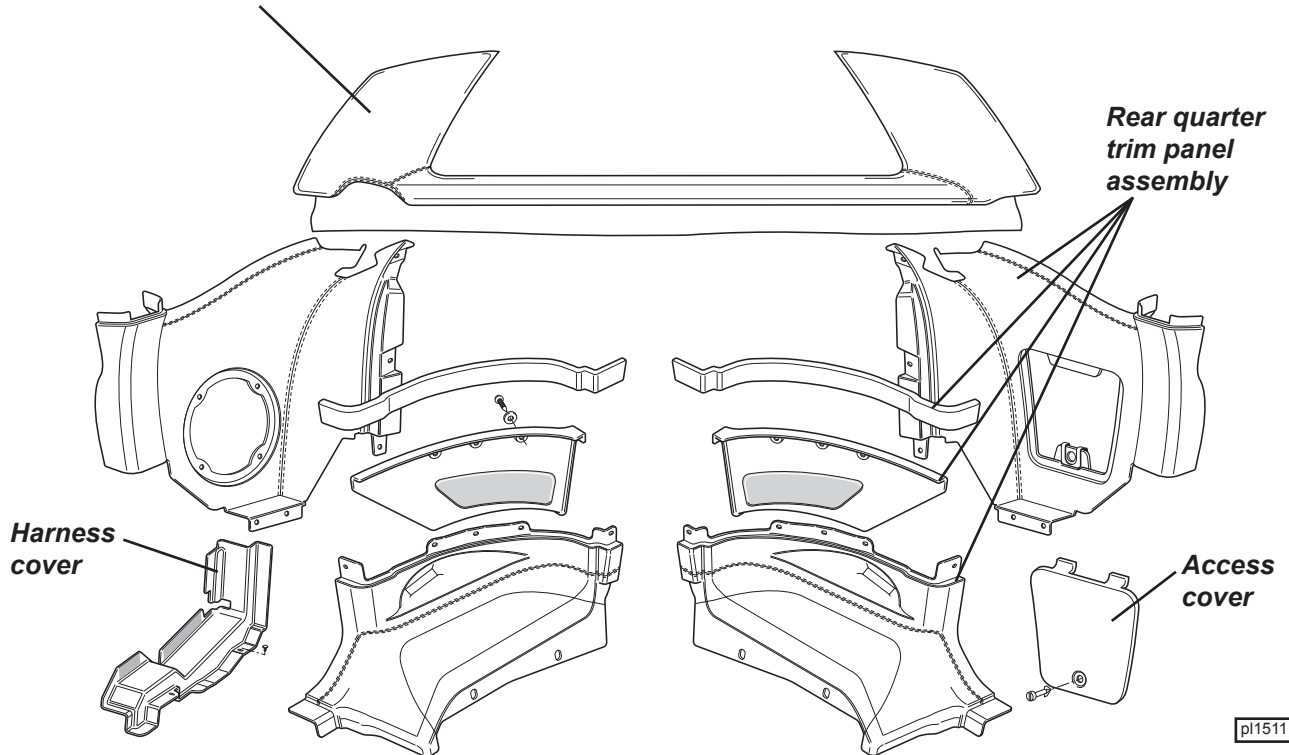

First remove the rear seat cushion or shelf, rear seat backrest or bulkhead insulation, and the rear window surround. Then:

- To allow the seat belt to be fed through the slot in the quarter panel, the door sill trim and harness cover must first be removed (see VE.3). Release the belt anchor rail from the sill and slide off the belt. Release the belt upper anchorage from the 'B' post.
- Pull off the rear section of the door weatherstrip.
- Release the two screws from the base of the panel, and the two at the upper rear edge.
- Pull the panel from its two spring clips around the window, and feed the seat belt through the panel aperture.

## VE.13 - REAR SEAT BACKREST OR BULKHEAD PAD

On 2+2 cars, the rear seat backrest is secured by a screw behind each backrest top insert pad, two screws at the bottom edge and Velcro patches. To remove the seat:

- Remove the rear seat cushion by pulling free from its Velcro fastening.
- Remove both backrest top insert pads by pushing upwards to release the spring clips. Release each of the single screw fixings thus revealed.
- Remove the two screws at the bottom edge of the backrest, and pull the panel free from its Velcro fastening.

On 2+0 cars, the insulating pad on the rear bulkhead is retained by Velcro pads.



### VE.14 - REAR WINDOW SURROUND

The rear window surround is secured by four spring clips. Pull the panel forwards to remove.

### VE.15 - ROOF LINING

The roof lining is retained by the sun visor brackets, the 'B' post upper trims, and two screws at the rear edge. To remove the roof lining panel:

- Pull the rear window surround from its 4 spring clips and remove the two screws at the rear edge of the roof lining.
- Release the seat belt upper anchorage from the 'B' pillar, and remove the 'B' post upper trim.
- Prise out the 'fir tree' button from the base of each windscreen pillar trim, and pull each trim panel from its three spring clips.
- Remove the three screws securing each of the sun visors and visor clips to the roof.



**AIRBAG SYSTEM**

**SECTION WF**

	<u>Sub-Section</u>	<u>Page</u>
General Description	WF.1	3
Airbag Tell Tale	WF.2	3
Data Link Connector	WF.3	4
Trouble Codes	WF.4	4
Lotus TechCentre	WF.5	4
Safety Precautions, Shipping, Storage & Disposal	WF.6	5
Theory of Operation	WF.7	7
Sensor & Diagnostic Module (SDM)	WF.8	9
Driver Airbag Module	WF.9	10
Rotary Connector	WF.10	11
Passenger Airbag Module	WF.11	12
Seat Belt Pre-tensioners	WF.12	13



*Illustration to follow*



## WF.1 - GENERAL DESCRIPTION

The Lotus Evora is equipped with dual stage airbags for both the driver and front seat passenger, in conjunction with pyrotechnic seat belt pre-tensioners for both front seat occupants. The airbag Supplementary Restraint System (SRS) is supplemental to the seat belts, and does not render the seat belts redundant. Seat belts have proven to be the single most effective safety device, and should be worn at all times by both driver and passenger, no matter how short the journey. Properly worn seat belts also ensure that the seat occupant is in the best position for full effectiveness of the airbag.

**WARNING: Airbags inflate with great force, in a fraction of a second, and if a vehicle occupant is too close to the airbag (less than 250 mm) or incorrectly positioned, they could be killed or seriously injured.**

The SRS is designed to operate when the vehicle is involved in a frontal, or near frontal collision, and the impact (rate of deceleration) as detected by any one of three vehicle mounted sensors, is sufficient to warrant airbag and seat belt tensioning protection to both front seat occupants. The 55 litre airbag for the driver is housed in the centre of the steering wheel, with a 100 litre bag for the passenger housed within the fascia. Three 'G' sensors are mounted in the vehicle to detect the rate of deceleration in a collision, and if the signal from any one of these should exceed a threshold value, the first stage of airbag inflation will be initiated. This will cause the airbags to inflate at a rate calculated to provide appropriate protection, whilst minimising the potential for airbag induced injury, especially where an occupant is not positioned optimally at the triggering moment. If a higher rate of deceleration is detected, indicating a more severe impact, the second stage inflator modules will be triggered to more rapidly inflate the airbags. In either case, both bags inflate in a fraction of a second to form a cushion for the driver's and passenger's upper bodies. The bags then deflate very rapidly to minimise any obstruction to the driver. Note that in order to protect against the danger of an unprogrammed firing of the second stage after a first stage airbag deployment, with the potential to cause injury to the vehicle occupant or carer, any first stage firing is followed almost immediately by triggering of the second stage, too late to affect the speed of airbag inflation, but ensuring that the airbag is then 'dead' and in a stable condition.

Initiated at the same time as the airbags is a pyrotechnic device on each front seat belt reel assembly, which uses rapid gas generation and a train of balls in a track to apply a tightening force to the belt reel and remove any slack from the belt. The force sustained by the belt and its user during the event, is then controlled by a torsion bar within the belt reel to limit the deceleration force to which the occupant is subjected.

Note that the SRS will deploy only in moderate to severe frontal and near frontal collisions, and is not designed to be triggered in rollover, rear or low speed frontal collisions, or in some types of side impacts.

The system incorporates a self-diagnostic facility, which continuously monitors the SRS electrical circuits for faults, and if necessary, lights a tell tale lamp in the instrument cluster. Most components of the SRS will require replacement after an airbag deployment.

### **Passenger Airbag Defeat (PAB) Switch**

If a rearward facing child seat is to be used in the front passenger seat of the Evora, it is essential to switch off the passenger airbag. If an accident should occur and trigger airbag inflation, the back of the seat could be subjected to a force sufficient to seriously injure or kill the child.

A PAB switch is located at the end of the passenger fascia, and is operated using the mechanical ignition key; insert the key and turn clockwise to the 'OFF' position, and withdraw the key. With the ignition switched on, a tell tale lamp in the instrument panel will light up red as a reminder that the passenger airbag has been disabled. To reinstate airbag operation, insert the key in the PAB switch and turn counterclockwise.



## WF.2 - AIRBAG TELL TALE

The airbag safety system, including the pre-tensioning seat belts, has a self-diagnostic feature which lights the red tell tale and sounds an audible alert if a fault is detected. As a circuit check, the tell tale will light for about six seconds following ignition switch on, and then go out. If the lamp remains lit, or comes on at any other time, a fault in the airbag system is indicated, which should be rectified without delay.

**WARNING: If the airbag tell tale is lit, the airbags may not inflate correctly in a crash, or may inflate without warning; or the pre-tensioning seat belts may not perform correctly. The SRS should be interrogated using the Lotus TechCentre and diagnosed and rectified without delay.**



## WF.3 - DATA LINK CONNECTOR (DLC)

In order to provide for communication with the SRS Sensing and Diagnostic Module (SDM), the Lotus TechCentre may be plugged into the special 16 terminal harness connector socket, known as a Data Link Connector, located beneath the driver's side fascia at the outboard side of the footwell. Communication with engine management and anti-lock brakes is also available via this connector.

*Illustration to follow*

## WF.4 - TROUBLE CODES

All the time the ignition is switched on, the Sensing and Diagnostic Module (SDM) continuously monitors the resistance of various parts of the SRS electrical circuit, and compares these values with pre-programmed tolerance bands to enable it to recognise 'faults' in the system and light the airbag tell tale lamp in the instrument cluster. If such a fault is detected, the SDM stores a 'Trouble Code' for that particular type of fault in its memory.

- i). Current (Present) Codes - Faults that are currently being detected. Current codes are stored in the SDM Random Access Memory (RAM), which will be cleared if the vehicle battery is disconnected.
- ii). History (Not present) Codes - All faults detected since the last time faults were cleared from the memory using the Lotus TechCentre. History codes are stored in the SDM Electronically Erasable Programmable Read Only Memory (EEPROM) and are not cleared if the battery is disconnected.

Vehicle crash data is also stored in coded form in the SDM and is not erasable. New SDMs are supplied only against V.I.N. and on exchange with the old unit.

## WF.5 - LOTUS TECHCENTRE

### **CAN BUS Diagnostics**

Controller Area Network (CAN) is an electronic standard to allow high speed communication between modules and controllers, via a serial data BUS. The BUS is a circuit linking the modules to the controller, consisting of a pair of cables, twisted together to reduce electromagnetic interference, and carrying a square wave voltage signal corresponding to '0's and '1's, coded in such a way as to identify and prioritise the individual messages. On the Evora, CAN based systems include; engine management system, instrument pack, tyre pressure monitoring and ABS/Traction Control/ESP.

A CAN compliant on-board diagnostic system is accessible via a 'stand alone' lap top PC loaded with 'Lotus TechCentre' software to allow the CAN based serial data to be read. A Vehicle Communication Device (VCD; T000T1476F) is used to connect the vehicle's Data Link Connector (DLC) to the laptop Lotus Techcentre. Engine programming, live data display, diagnostics of engine, ABS and airbag systems, and service tell tale lamp resetting are all carried out via the Lotus TechCentre.

The minimum specification of the laptop computer for installation of the Lotus Techcentre software is as follows:

Processor 1.70 Ghz;  
1 GB RAM;  
40 GB HDD;  
CDRW DVD ROM;  
WIN XP PRO;  
USB interface;  
Ethernet or Wireless LAN



Note that this laptop should be dedicated totally to the Lotus Techcentre, with no other software installed.

### WF.6 - SAFETY PRECAUTIONS, SHIPPING, STORAGE & DISPOSAL

**WARNING: The SDM can maintain sufficient voltage to cause an airbag deployment for up to 20 seconds after the battery has been disconnected. Before working on the airbag system, or in close proximity to an airbag, first take the following precautions to temporarily disable the airbag system:**

1. Turn off the ignition.
2. Before disconnecting the battery, use the Lotus TechCentre to read any stored trouble codes.
3. Disconnect the negative (earth) lead from the battery and tape back to ensure that no contact with the battery negative terminal can be made.
4. Wait for 30 seconds.
5. If working on or near the steering wheel, first unclip the top part of the column shroud, then remove the lower part after releasing the three retaining screws.
6. Locate and unplug the airbag harness from the rotary connector. Note that the connector socket is fitted with 'shorting bars' which automatically interconnect the high and low terminals of the airbag to prevent unscheduled deployment caused by a voltage differential.

When service work has been completed, reconnect the harness plug secured with its locking feature, and reconnect the battery. Ensure the airbag tell tale lights for a few seconds with ignition and then goes out.

#### **Storage**

- Airbag modules and SDMs should not be stored at temperatures above 176°F (80°C).
- Airbag modules and SDMs should not be stored in damp conditions.
- Do not store airbag module or SDM boxes more than two high.
- Always store and handle airbag modules and SDMs in an upright position. Never store SDMs upside down.

#### **Sensor & Diagnostic Module (SDM) & Forward Crash Sensors**

The SDM and forward crash sensors are calibrated specifically to the Evora, and are mounted in a dedicated manner in specific positions. Never use SRS components from any other vehicle, or modify their mounting to the Evora.

#### **WARNING:**

- **Handle the SDM with great care. Never strike or jar the SDM as this could cause airbag deployment and result in personal injury or improper operation of the SRS.**
- **All module and mounting bracket bolts must be correctly installed and tightened to assure proper security and operation.**
- **Never power up the SRS when the SDM is not properly mounted and secured, since the SDM is easily triggered when not attached, and could result in deployment causing personal injury.**
- **Do not use or attempt to repair a damaged SDM.**

#### **Inflator Module**

*Live (Undeployed) Inflator Modules:* Special care is necessary when handling and storing a live (undeployed) inflator module. In the unlikely event of accidental deployment, violent movement of the inflator module could result in personal injury.

#### **WARNING:**

- **When carrying a live inflator module, make sure the bag and trim cover are pointed away from you. In case of an accidental deployment, the bag will then deploy with minimal chance of injury.**
- **When placing a live inflator module on a bench or other surface, always face the bag and trim cover upwards, away from the surface. This is necessary so that a free space is provided to allow the air bag to expand in the unlikely event of accidental deployment. Otherwise, personal injury may result.**
- **Never carry the inflator module by the wires or connector on the underside of the module.**





- **Do not use or attempt to repair a damaged inflator module, and NEVER apply any electrical power to the module except as specified in the diagnostic procedures.**

### **Inflator Module Shipping Procedures for Live (Undeployed) Inflator Modules**

The transportation of uninstalled inflator modules is regulated by the Hazardous Materials Regulations of the U.S. Dept. of Transportation (DOT) and most state governments. Special procedures are required for transportation. Lotus recommends that the dealers and repair shops check with the hazardous material section of their respective state police authority for applicable shipping requirements.

For all shipments on public roads, the DOT has classified the uninstalled inflator module as a flammable solid under a special exemption process. It should always be shipped and stored in the approved cardboard container in which it is purchased. The container should be marked with "Flammable Solid, n.o.s., UN1325, DOT-E8236" and labelled with the specified red and white flammable solid label. Each shipping location must have a copy of the exemption on file. A shipping paper (e.g., a customer receipt) must accompany each shipment and identify the module as "Flammable Solid, n.o.s., UN1325, DOT-E8236". Transportation, storage and handling of the module should be in accordance with the exemption and the requirements for a DOT flammable solid. Do not expose the module to heat, open flame, impact, friction, or electrical charge.

### **Inflator Module Scrapping Procedures**

**WARNING: Failure to follow proper SRS inflator module disposal procedures can result in airbag deployment which may cause personal injury. Undeployed inflator modules must not be disposed of through normal refuse channels. The undeployed inflator module contains substances that can cause severe illness or personal injury if the sealed container is damaged during disposal. Disposal in any manner inconsistent with proper procedures may be a violation of federal, state and/or local laws.**

Reference should be made to the local State authority for the correct disposal procedures for deployed inflator modules.

### **Vehicle Scrapping Procedures**

Some vehicles equipped with SRS that have live (undeployed) inflator modules may have to be scrapped because they have completed their useful life, or have been severely damaged in a non-deployment type accident. The following procedure should be followed when scrapping a vehicle with an undeployed module.

1. Follow the safety procedure detailed in sub-section WF.6 to turn off the ignition, disconnect the battery and unplug the inflator module harness.
2. Follow the procedure detailed in sub-section WF.11 to gain access to the passenger airbag module.
3. At the driver's airbag harness alongside the steering column, cut the harness side of the SRS wiring approx. 75 to 150 mm from the yellow connector.
4. Splice 2 wires at least 6 metres long to the red/blue and the red/green coloured cables in this connector block.
5. Reconnect the yellow 4-way connector block now equipped with 2 x 6 m long cables.
6. Check that the inflator module is secured to the steering wheel.
7. Remove all loose objects from the front seat.
8. Ensure no one is in the vehicle.
9. Stretch wires away from car to their full length.
10. Apply 12 volts across the wires to deploy the air bag.
11. Do not touch the inflator module area for 20 minutes due to the heat generated during deployment.
12. Wear gloves and safety glasses to handle the deployed air bag. Wash your hands with mild soap and water afterwards.
13. Repeat steps 3 to 12 for the passenger airbag, splicing the 6 m cables into the two wires connecting the SDM to the airbag.



## Deployed Inflator Modules

**WARNING:** Safety precautions must be observed when handling a deployed inflator module. After deployment, the air bag surface may contain a white packing powder used to ease deployment. Always wear gloves and safety glasses when handling a deployed inflator module, and wash your hands with a mild soap and water afterwards.

### Inspections Required After an Accident

All SRS system components, including harnesses and brackets, must be inspected after an accident. If any are damaged or bent, they must be replaced even if a deployment did not occur. If the SRS was deployed, the following components MUST be renewed even if there is no visible damage to the parts:

- Driver airbag module;
- Passenger airbag module;
- Sensor & Diagnostic Module (SDM);
- Driver and passenger pyrotechnic seat belt assemblies;
- Rotary connector;
- Passenger airbag mounting brackets (if passenger airbag was deployed);
- Main fascia panel (if passenger airbag was deployed);

Inspect the steering column for damage or telescoping (see Section HG) and column mounting brackets for damage. Inspect the front subframe longerons, and the mounting of the two forward crash sensors for damage or distortion. Inspect the chassis scuttle beam in the area of the passenger airbag mounting brackets for damage or distortion. Inspect the SRS wiring harness and connectors for damage or any signs of overheating. Inspect both front seat shells, and all seat mounting brackets and runners. Check all seat belt mountings and brackets for damage or distortion.

Do not attempt to repair the steering column or chassis or any of the above mentioned components. Service only by replacement.

**WARNING:** Proper operation of the SRS system requires that any repairs to the vehicle structure return it to its original production configuration. Deployment, or any visible damage to the SRS components and/or their respective mounting brackets requires replacement, not repair.

## WF.7 - THEORY OF OPERATION

The key components of the Supplementary Restraint System (SRS) are the following:

- Sensor & Diagnostic Module (SDM);
- Forward crash sensors;
- Driver airbag module;
- Passenger airbag module;
- Rotary connector;
- Seat belt pre-tensioners.

### **Sensor & Diagnostic Module (SDM);**

The SDM is the main electronic control unit (ECU) of the SRS, and incorporates an accelerometer to detect rates of forward deceleration in conjunction with two forward crash sensors. When data from these sensors meets collision recognition criteria over a certain threshold, the SDM triggers as a single set, the driver and front passenger airbags in either stage one or stage two mode, and both front seat belt pre-tensioners. Additional functions are to maintain an electrical energy reserve in case of vehicle battery power interruption during the accident, operation of a dash mounted tell tale lamp, and an electronic diagnostic and event recording facility accessible via a workshop scanner tool.

The unit is mounted in an alloy box bolted to the centre underside of the chassis scuttle beam, accessible from the footwells.

The following functionality is provided by the SDM;

- Sensing of frontal impact crash events and vehicle specific discrimination between airbag non-deployment and stage one or stage two deployment-requiring events as well as activation of the front seat belt pre-



tensioners.

- In case of a required deployment, timely switching of the activation current for the deployment loops.
- Detection of electrical system faults which may influence the readiness of the system to deploy, or increase the probability of an inadvertent deployment by:
  - continuous electrical monitoring of all deployment circuits (without any effect on the readiness of the system);
  - continuous monitoring of the supply voltage and the lamp circuitry (dependent on lamp driver activation status);
  - SDM self test;
  - activation of a tell tale lamp in case of a detected system fault.
- Fault storage and 'Crashrecording' within EEPROM ('crashrecording': recording of system parameters {e.g. fault status in deployment events}).
- Diagnostic communication using an ISO9141 protocol.

### Frontal Impact Sensing and Deployment

The SDM and the two forward crash sensors contain accelerometers which provide a nearly linear proportional electrical representation of the acceleration experienced by the vehicle along the longitudinal axis. This signal is amplified and filtered to reduce unwanted electronic noise and to compensate for offset drifts. The filtered signal is then digitized to provide an input for evaluation by the crash algorithm. As soon as the crash algorithm detects that pre-defined thresholds have been exceeded, the SDM activates both airbags in either stage 1 or stage 2 mode, and both front seat belt pre-tensioners.

To enhance system reliability under normal driving conditions, an additional electromechanical 'safing' sensor is included within the SDM to ensure that the SRS is armed only when significant deceleration occurs. In order to protect against undesired deployments in case of severe EMI, humidity or accelerometer fault, the deceleration condition monitoring by the safing sensor occurs in addition to, and independent of, the crash algorithm.

Note that neither the seat belt pre-tensioners nor the airbags will be activated by the SDM as long as the diagnostic mode is active.

### Fault Display

The following conditions lead to a fault display in the form of continuous illumination of the airbag tell tale:

- One or more trouble codes requiring tell tale lamp activation in the 'historic' and 'present' condition are stored in the SDM's EEPROM.
- One or more trouble codes requiring tell tale lamp activation in the 'present' condition only are stored in the SDM's EEPROM, the condition of which is, or has been, 'present' in the current operating cycle. For all faults requiring four consecutive incidents for a trouble code to be set, the 'present' condition and fault display will be activated already after two consecutive events if the related trouble code has already been stored in a previous operating cycle.
- Faults concerning the voltage supply (overvoltage/undervoltage) will lead to tell tale activation only until the regular voltage range has been reached again (turn-off delay max. 5s after return from undervoltage and max. 20s after return from overvoltage). There are no related trouble codes.
- The airbag tell tale will not be activated due to SRS warning lamp related faults.
- The tell tale will be activated immediately after entering the diagnostic mode, or on deployment of the SRS.

Excluding the exceptions stated above, it is not possible to switch off the tell tale other than by resetting the fault codes stored in the EEPROM. This is not possible after an airbag deployment - the SDM must be renewed.

The following delays apply for the detection and display of faults. The delays apply from the extinguishing of the tell tale, following the ignition switch on bulb check period:

- 1 to 5 secs - for external deployment circuit faults and overvoltage supply.
- 12 to 20 secs - for undervoltage supply.
- up to 15 secs - for SDM internal faults.



The tell tale will be activated without SDM intervention in the following situations:

- the minimum voltage of 8.0 V has not been exceeded after switching on the ignition.
- the energy reserve (in SDM) has run low, which may be caused by supply voltages below 7.8 V.
- the watchdog has interfered.

A trouble code readout using tell tale blink codes is not implemented.

## Power Supply & Grounding

The nominal supply voltage of +12 volts is derived from terminal 5 when the ignition is switched on. The SDM internal ground (terminal 7) must be securely connected to the vehicle chassis ground. To provide redundant grounding, the SDM housing is internally connected to the ground connector pin.

## Supply Voltage Range

The SDM is designed to operate within the following voltage ranges:

*System fault detection, SDM self test:* min. 8.0 V; max. 16.0 V

Below 10.0 V system readiness may be delayed by 3 s.

Below 9.0 V system readiness may be delayed by 10 s.

System fault detection and SDM self test are reduced as long as an undervoltage condition is detected, which could already apply for supply voltages below 10.5 V.

*Activation of airbags:* min. 8.0 V; max. 16.0 V.

*Activation of seat belt pre-tensioners:* min. 10.0 V; max. 16.0 V.

## Energy Reserve

Energy reserve capacitors within the SDM are provided to allow SRS deployment if the vehicle battery power supply is interrupted during the time of vehicle impact. The capacitors provide full support of the acceleration sensing and airbag initiation capability for a minimum of 150 ms after a loss of external power supply, provided that before the loss, the SDM had been supplied with:

at least 10.0 V for at least 10 s; or

at least 9.0 V for at least 13 s; or

at least 8.0 V for at least 20 s.

The capacitors will be discharged down to a point where no initiation of airbags is possible within a max. of 20 s after removal of the power supply.

## WF.8 - SENSOR & DIAGNOSTIC MODULE (SDM)

### To Replace SDM

**WARNING: The SDM must be replaced after SRS deployment. Do not attempt to repair or reuse.**

The SDM is mounted in an alloy box bolted to the centre underside of the scuttle beam.

1. Follow the safety procedure detailed in sub-section WF.6 to turn off the ignition, disconnect the battery and unplug the rotary connector.
2. From the footwells, release the 8 setscrews securing the SDM mounting box to the scuttle. Release the three screws securing the SDM to the box and unplug the two harness connectors.

Refitment of the SDM is a reversal of the removal procedure, torque tightening the fixing screws for SDM and mounting box to 9 Nm.



## WF.9 - DRIVER AIRBAG MODULE

**WARNING: Safety precautions must be observed when handling a deployed airbag. After deployment, the airbag surface may contain a white packing powder used to ease deployment. Always wear gloves and safety glasses when handling a deployed inflator module, and wash your hands with a mild soap and water afterwards.**

The driver's airbag (or inflator module) is housed in the hub of the steering wheel, beneath a moulded trim cover designed to hinge open in the event of deployment. The module comprises:

- an inflatable fabric bag;
- an inflator (canister of gas generating material)
- an initiator (or 'squib')

The complete module also serves as a horn operating pad, such that pressing anywhere on the steering wheel centre trim will operate the horns. The module is spring mounted to a baseplate secured to the steering wheel hub, the baseplate carrying 4 earthed electrical contacts which correspond with 4 opposing contacts supplied with 12 volts and mounted on the module itself. Closing any of the contacts will ground the circuit and sound the horns.

When the vehicle suffers a forward deceleration of sufficient magnitude to close both the safing sensor and the integrated accelerometer within the SDM or one of the two forward crash sensors, current flows through the stage 1 or stage 2 deployment loop of both the driver and passenger airbag module initiators and ignites the gas generating material. Each bag inflates in a fraction of a second, the driver's bag bursting open the steering wheel centre trim cover, and then deflates via vents in the bag, with the whole cycle taking less than one second. The airbag is designed for a single deployment, and must then be renewed.

In order to help prevent unwanted deployment of the driver's airbag when servicing the steering column or other SRS components, a shorting bar is incorporated into each of the two connector sockets on the rotary connector (one connector for each airbag stage). The shorting bar operates when the connector is unplugged, to short across the feed and return connections to the airbag. Thus, if a positive feed, or earth is inadvertently applied to the connector terminals, both sides of the inflator module will be subject to the same electrical potential, and no deployment will occur. The same feature is included in the airbag module connector sockets.

### **To replace driver's airbag**

**WARNING: The following procedures must be followed in the order listed to temporarily disable the airbag system whilst working in the immediate vicinity of an airbag. Failure to follow this procedure could cause unintended airbag deployment, resulting in personal injury and unnecessary airbag system repairs.**

1. Follow the safety procedure detailed in sub-section WF.6 to turn off the ignition, disconnect the battery and unplug the rotary connector.
2. On the reverse side of the steering wheel, release the two Torx head screws, accessible via holes in the plastic shroud around the steering wheel hub. Withdraw the airbag module and disconnect the two airbag harness connectors and the two horn leads.

**WARNING: When carrying a live airbag module, make sure the bag and trim cover are pointed away from you. In case of an accidental deployment, the bag will then deploy with minimal chance of injury. When placing a live airbag module on a bench or other surface, always face the bag and trim cover upwards, away from the surface. This is necessary so that a free space is provided to allow the airbag to expand in the unlikely event of accidental deployment.**

3. If a driver's airbag is deployed, refer to steering sub-section HI.5 to determine whether the steering column telescoping mechanism has been activated, and if necessary, renew the column assembly.
4. Mate the two harness connectors to the new airbag module sockets, matching the colour coding, and connect the two horn leads. Locate the module into the steering wheel and retain with the two Torx head retaining screws, tightening to 7 Nm.



5. When all service work is complete, connect the harness plugs to the rotary connector sockets and refit the column shrouds. Reconnect the battery, turn on the ignition and check that the airbag tell tale lights for a few seconds and then goes out.

### WF.10 - ROTARY CONNECTOR

**WARNING: The rotary connector MUST be replaced after SRS deployment even if there is no visible damage.**

The rotary connector is a device which fits between the steering wheel and column, and allows the steering wheel to turn whilst maintaining electrical continuity to the airbag module and horn buttons. The assembly consists of an annular housing fitted over the top end of the steering column, and containing a coil of wires providing feed and return circuits for the first and second stage airbag initiators, horn buttons and cruise controls.

The steering column side of the device is fitted with a connector block into which is plugged a branch of the main vehicle harness. The steering wheel side of the device has a divided connector block for the cruise control jump harness, and the airbag/horn jump harness. The coil housing is constructed in two parts, with the outer part fixed to the outer (stationary) column, and the inner part keyed to the steering wheel. The two parts of the coil housing slide inside of each other in such a way as to allow the steering wheel to be rotated through its full travel, lock to lock, whilst maintaining an unbroken feed to each of the circuits in the steering wheel hub, via the continuous wires in the coils.

In order to help prevent unwanted deployment of the air bag when servicing the steering column or other SIR components, a shorting bar is incorporated into the rotary connector column side connector socket. This shorting bar operates when the connector is unplugged, to short across the feed and return connections to the inflator module. Thus, if a positive feed, or earth is inadvertently applied to the connector terminals, both sides of the inflator module will be subject to the same potential, and no deployment will occur.

When servicing the rotary connector, it is most important that the correct orientation of the connector is maintained on refitment, or the connector will run out of travel and be broken.

#### **To replace the rotary connector**

1. Remove the airbag module from the steering wheel (see sub-section WF.8).
2. Disconnect the cruise control harness plug.
3. Ensure the wheels are pointing straight ahead, match mark the wheel to the column, and remove the steering wheel retaining bolt. Note that the wheel is located on a steep angle hexagonal taper on the column.  
**CAUTION: If excessive force is applied to either the steering wheel or column, the break-out inserts securing the column to the fascia bracket may be disturbed, necessitating replacement of the complete column. If necessary, use an appropriate puller.**
4. Unplug the harness from the two column lever switches and unclip each switch from the carrier.
5. Unplug the harness from the column side of the rotary connector, unclip the carrier from the outer column, and slide the the rotary connector from the steering column.
6. Refit in reverse order to removal, but before fitting the steering wheel, it is essential to centralise the rotary connector, or the unit will be broken when lock is applied. Turn the connector fully clockwise until it tightens, and then turn back just over two turns until the red marker appears in the square window. Note that this instruction is printed on the rotary connector. Ensure the road wheels are pointing straight ahead and fit the steering wheel with the match marks aligned. Tighten the steering wheel retaining bolt to 50 Nm. When fitting the jump harness for the cruise controls, ensure the cable is routed through the channel provided in the steering wheel carrier.
7. After re-assembly, check that the airbag tell tale lights for a few seconds with ignition, and then goes out.



### WF.11 - PASSENGER AIRBAG MODULE

**WARNING: Safety precautions must be observed when handling a deployed airbag. After deployment, the airbag surface may contain a white packing powder used to ease deployment. Always wear gloves and safety glasses when handling a deployed inflator module, and wash your hands with a mild soap and water afterwards.**

The passenger's airbag (or inflator module) is mounted on the underside of the main fascia panel and also braced to the rear face of the chassis scuttle beam. An airbag 'door' in the top surface of the fascia, is designed to break open under the force of airbag deployment, and, hinging at its front end, direct the inflating bag into the area of optimum effectiveness.

The passenger's airbag (or inflator module) comprises:

- an inflatable fabric bag;
- an inflator (canister of gas generating material)
- an initiator (or 'squib')

When the vehicle suffers a forward deceleration which closes the safing sensor, and the signal from the SDM accelerometer or either of the two forward sensors indicates that the severity is sufficient to require airbag deployment, current flows through the stage 1 or stage 2 deployment loop of both the driver and passenger airbag module initiators and ignites the gas generating material. Each bag inflates in a fraction of a second, the passenger's bag bursting open the fascia airbag door, and then deflates via vents in the bag, with the whole cycle taking less than one second. The airbag is designed for a single deployment, and must then be renewed.

#### **To replace passenger airbag**

**WARNING: The following procedures must be followed in the order listed to temporarily disable the airbag system whilst working in the immediate vicinity of an airbag. Failure to follow this procedure could cause unintended airbag deployment, resulting in personal injury and unnecessary airbag system repairs.**

- i). Turn off the ignition.
  - ii). Before disconnecting the battery, use the Lotus TechCentre to read any stored trouble codes.
  - iii). Disconnect the negative (earth) lead from the battery and tape back to ensure that no contact with the battery negative terminal can be made.
  - iv). Wait for at least 30 seconds to allow the SDM capacitors to discharge.
  - v). Open the glovebox, release the tether and damper cords, and lower the glovebox fully.
  - vi). Remove the glovebox back panel; remove the two screws into the underside of the fascia panel, and prise out the four 'fir tree' fasteners. Disconnect the glovebox lamp.
  - vii). Access is now available to unplug the airbag harness yellow connector.
1. Replacement of the passenger airbag requires that the main fascia panel be removed - refer to sub-section VE.8.
  2. Release the four fixings securing the airbag module to the underside of the fascia.

**WARNING: When carrying a live airbag module, make sure the top surface of the module is pointed away from you. In case of an accidental deployment, the bag will then deploy with minimal chance of injury. When placing a live airbag module on a bench or other surface, always arrange for the deployment face to be uppermost. This is necessary so that a free space is provided to allow the airbag to expand in the unlikely event of accidental deployment.**

3. If an airbag deployment has occurred, the chassis scuttle beam and main fascia panel must be carefully examined for damage or distortion and replaced if necessary. The airbag door will always need replacing.



**WARNING:** Proper operation of the SRS system requires that the vehicle structure remains in its original production configuration. Any damage to the SRS components and/or their respective mounting brackets, including the chassis, requires replacement, not repair.

4. Fit the airbag module to the fascia panel and tighten the four M6 nuts to 10 Nm.
5. Fit a new airbag door to the fascia panel and tighten the two M6 nuts to 10 Nm. Ensure the 2 plastic barb clips are correctly engaged.
6. Refit the fascia panels (see section VE) and plug in the passenger airbag harness connector.
7. When all service work is complete, check that the airbag tell tale lights for a few seconds with ignition, and then goes out.

## WF.12 - SEAT BELT PRE-TENSIONERS

### **WARNING:**

- Failure to comply with the instructions, safety standards and operating procedures as described in this section, may cause vehicle damage and/or personal injury.
- Both driver and passenger front seat belt assemblies must be replaced after SRS deployment. Do not attempt to repair or reuse.

### **Device Operation**

Initiated at the same time as the airbags, is a pyrotechnic device on each front seat belt reel assembly to apply a tightening force to the belt reel and remove any slack from the belt. The force sustained by the belt and its user during the event, is then controlled by a torsion bar within the belt reel to limit the deceleration force to which the occupant is subjected. When airbag/pre-tensioner triggering conditions apply, the SDM signals ignition of a gas generator on each front seat belt assembly, the pressure from which forces a train of balls around a tubular track to apply a retraction force to the belt reel.

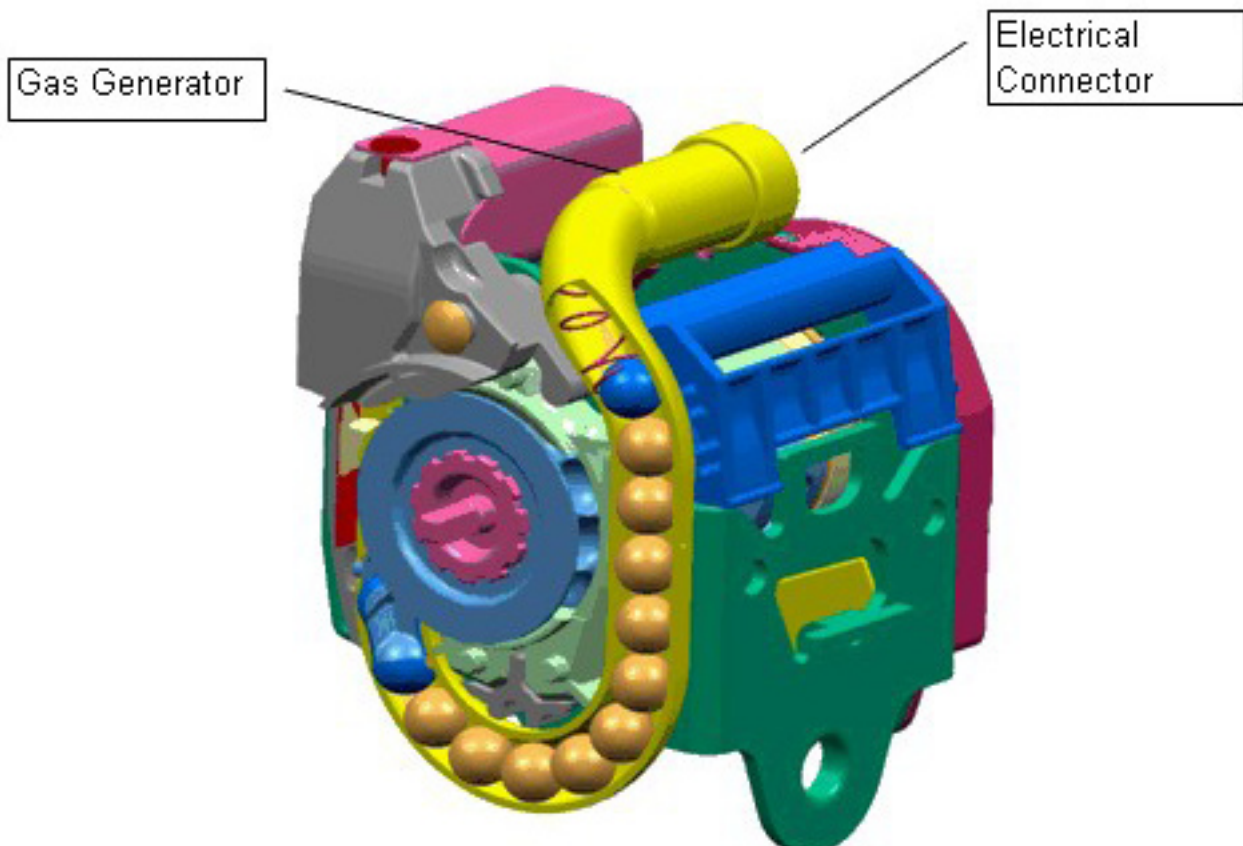





The belt pre-tensioning mechanism is designed to operate only once, such that both front belt assemblies should be renewed after airbag/seat belt pre-tensioner deployment. Activation of the pyrotechnic mechanism is indicated by the belt reel being locked, and allowing neither extraction nor retraction of the belt.

### To replace front seat belt assembly

Each front seat belt reel assembly is secured to the seat belt mounting frame/roof hoop by a single bolt, with an orientation tag on the belt reel engaging with a slot in the mounting plate.

**WARNING: Before removing or refitting a pyrotechnic seat belt assembly, the ignition key should be withdrawn, and the battery leads disconnected from both positive and negative terminals, and isolated to ensure that accidental contact cannot occur.**

1. Remove the rear quarter trim panel (refer to sub-section VE.11).
2. Unplug the vehicle harness from the belt tensioner initiator, and release the belt reel assembly retaining bolt.
3. Refit in reverse order to removal, tightening the belt reel securing bolt to 33 Nm.
4. When all service work is complete, check that the airbag tell tale lights for a few seconds with ignition, and then goes out.

### Safety Standard

The pre-tensioning function is energised via pyrotechnic materials, therefore manipulation, handling and storage **MUST** be performed to the specified procedures as described to avoid any occurrence of injury to the operator or damage to the pre-tensioning unit.

In normal conditions, the pre-tensioner assembly can only be activated through the action of the electric ignition control during impact. During the activation phase of the pyrotechnic charge, small gas quantities are developed. The main constituent of the gases is Nitrogen:

**Note! This gas is not toxic.**

The pre-tensioner assemblies must be protected against exposure;

- To temperatures over 90°C (195°F) at contact with surfaces
- 90°C during 106 hrs.
- From sparks and naked flames.

**WARNING: If exposed to temperatures in excess of 140°C, self-ignition of the pyrotechnic charge of the gas generator may occur. Exposure to temperatures in excess of 165°C, self-ignition of the pyrotechnic charge will occur.**

Also, if exposed to temperatures between 90°C (285°F) and 165°C (330°F), deterioration of the pyrotechnic charge ignition is possible. The consequences of this could be failure to activate at prescribed levels. The pre-tensioner must be protected against stresses, shocks and dropping. Pre-tensioners that have been subjected to such treatment must be discarded and returned to the supplier with accompanying paperwork describing the reasons for return.

Never store pre-tensioner assemblies with other flammable or combustible materials. Gas generators **MUST** be prevented from coming into contact with acid, water, grease and heavy metals: **Contact with these substances may cause toxic or dangerous gases, or explosive mixtures.**

Any residual fuel of the gas generator, not burned during ignition, is slightly flammable. The unit, therefore, must **never** be disassembled, damaged or the parts manipulated. Any advertising or demonstrations of the pre-tensioner assembly should only be carried out using inert pre-tensioners (without the pyrotechnic charge). The base of the pre-tensioner must be painted green, with visible and indelible wording, stating '**Inert Assembly**'. It must incorporate the KSS logo, signed with indelible ink by the person responsible for the supply of the product.

**WARNING: Never disassemble the pre-tensioner or any of its components!**



### Transportation of belt with pre-tensioner

Transport on road vehicles should be carried out with the assemblies stored in the luggage compartment. Never transport in the passenger compartment. Never transport the pre-tensioner manually or holding it by the webbing: this can result in damage to the assembly.

### Storage of belt with pre-tensioner

Belts with pre-tensioning elements should be stored in containers or boxes that can be locked with a key, and ventilated. They MUST be stored in an area free from flames and heat sources. On completion of work, or during work break periods, pre-tensioner belts should be returned to the storage container and locked with a key.

### Disposal of belts with pre-tensioner

Charged pre-tensioners to be scrapped and not fitted to a car must be activated. This should be carried out only by the belt manufacturers, or specialised workshops.

### Vehicle disposal

Charged pre-tensioners fitted to a vehicle MUST be removed before the vehicle is dismantled for scrapping. If the pre-tensioner is not activated during an accident, the device must be considered as still to be in a 'charged' condition.

### General safety instructions/dangers for health

- When handling activated pre-tensioners, use safety glasses and vinyl or nitrile protection gloves.
- After handling a loaded pre-tensioner, wash hands with soap and water.
- There is no danger of exposure to propellants in the sealed system. The propellant mix is in a solid state, therefore no inhalation is possible, even if the gas generator cartridge is broken.
- Avoid skin contact and do not ingest the propellant.

### First aid

*Ingestion:* Help the person vomit if conscious. Call a physician.

*Skin contact:* Wash immediately with soap and water. Call a physician.

*Eyes:* Wash the eyes immediately with running water for a minimum of 10 minutes. Call a physician.

*Inhalation:* Take the person immediately to fresh air. Call a physician.

### General notice

Storage, transport, dismantling and/or recycling of the pre-tensioner shall be carried out according to the legal and local regulations, taking account also of directives for masonry, fire fighting, transport, environmental protection and the safety and health of all staff.

**WARNING:** The seat belt pre-tensioner devices fitted on the Lotus Evora are designed and calibrated specifically for this particular model. Pre-tensioners must not be adapted, re-used or installed on any other vehicle - they must only be fitted to the prescribed vehicle with specific homologation continuity.

Any attempt to re-use, adapt or install pre-tensioners on a different vehicle can cause severe or fatal injuries to the occupants during normal operation as well as the result of an accident.