



WHEELS & TYRES

SECTION GF - M111 ELISE

	<u>Sub-Section</u>	<u>Page</u>
General Description	GF.1	2
Winter Tyres & Snow Chains	GF.2	4
Emergency Punctured Tyre Inflator	GF.3	4
Security Wheelnuts	GF.4	5



GF.1 - GENERAL DESCRIPTION

The single piece, light alloy roadwheels, in various styles, are fitted with Pirelli P Zero tyres, engineered to provide the optimum balance of ride and handling characteristics. Pirelli P Zero are the recommended tyres for use on the vehicle under normal road conditions. In order to fully exploit the dynamic qualities and packaging opportunities, the wheel and tyre sizes are different front and rear, so that interchanging of wheels and tyres between axles is not permissible. Note that the tyre tread pattern is asymmetric with the tyre sidewalls marked 'Inner' and 'Outer'; check that replacement tyres are correctly fitted. Part of the tread pattern is also directional in appearance, but the direction of rotation has no bearing on the tyre performance.

The tyres should be inspected frequently by the vehicle user, and also at every service, for signs of cuts, abrasions or other damage, and for any uneven tread wear patterns. Uneven treadwear may indicate that the suspension geometry or dampers require attention. Care should be taken when parking to avoid tyre contact with high or sharp edged kerbs, as mistreatment of this nature can cause internal damage to the tyre structure which may not be readily apparent. The alloy wheel rims may also be distorted or damaged by careless parking, and result in wheel imbalance or loss of tyre pressure. Safety considerations should always be paramount when assessing tyre condition and serviceability, and the tyres replaced if any doubt exists, or if the legal tread depth limits are approached.

The cold tyre pressures should be checked every week, or every 1,000 miles (1,700 km), whichever is the sooner, and corrections made as necessary. Under-inflation will cause excessive wear, rapid deterioration of the tyre sidewalls and heavy steering, whereas overinflation results in a hard ride and increased susceptibility to tyre damage. Both conditions will cause a degradation in the vehicle handling qualities. It is important that the tyre pressures are adjusted only when the tyres are cold (driven less than one mile), as the pressures may increase by 0.3 - 0.5 bar (4 - 8 lb/in²) when the tyres are warmed to normal running temperature. The tyre valve dust cap should always be replaced in order to prevent the ingress of dirt and moisture into the valve, which could cause leakage.

When balancing the wheel and tyre assemblies, the wheels should be located by the centre spigot - NOT by the wheel bolt holes. In order to maintain the correct handling feel and minimum steering wheel shake, it is very important that the radial and lateral run out of the tyres are to the high standard required by Lotus Cars. If any difficulty is experienced with replacement tyres, refer to the tyre manufacturer.

Wheel & Tyre Specification

Wheels

Type	- std. prior April '99 *	AWI light alloy; 5 split-spoke style	* Approx. VIN X 6429
	- std. from April '99 *	Rimstock light alloy; 12 spoke style	
	- 111S & std. option	O.Z. light alloy; 6 spoke style	
Size - front		5.5J x 15CH/H2 ET14	
- rear	- std	7J x 16H2 ET16	
	- 111S & std. option	7.5J x 16H2 ET10	
PCD		95.25 mm	
Inset - front		+ 14 mm	
- rear	- std	+ 16 mm	
	- 111S & std. option	+ 10 mm	
Wheel nut torque		80 - 85 Nm	
Radial run-out at bead seat		0.3 mm max.	
Lateral run-out at rim flange		0.3 mm max.	



AWI

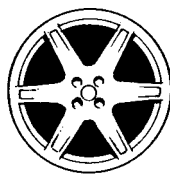

O.Z.

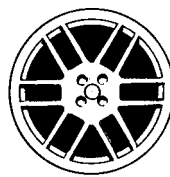

Rimstock

3401a



Note that the inset figure is the offset of the wheelrim centreline relative to the wheel/hub mounting face. A positive figure indicates that the wheelrim centreline lies inboard of the wheel mounting face, whereas a negative figure means the wheelrim centreline is outboard of the mounting face.

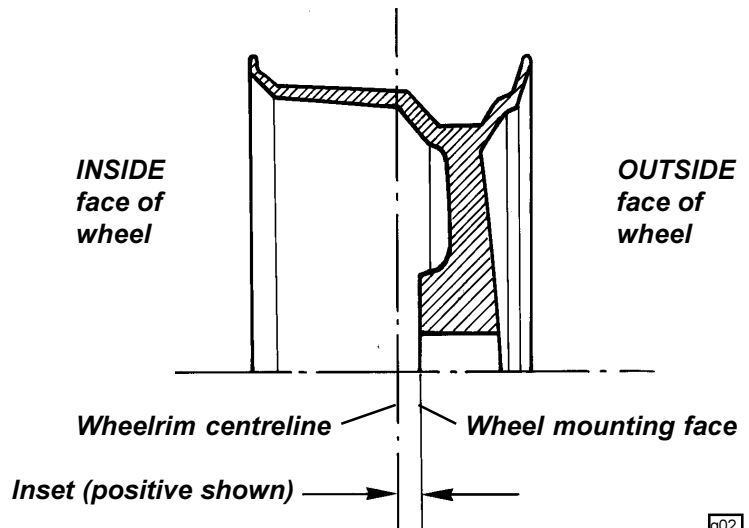

Tyres - Standard Fitment

Type		Pirelli P Zero
Size - front		185/55 R15 81V
- rear	- std	* 205/50 ZR16 87W
	- 111S & std. option	# 225/45 ZR16
Pressure (cold) - front		1.6 bar (23 lb/in ²)
- rear	- 205	1.7 bar (24.5 lb/in ²)
	- 225	1.9 bar (27.5 lb/in ²)

* *Pirelli Zero 205/50 rear tyres:* There are variations in the specification of Pirelli tyres with this designation, dependent on where and when they were manufactured. Lotus fitment should be:

- either: i) Made in Italy (moulded on inside tyre wall)
- or: ii) Made in Great Britain (moulded on inside tyre wall) **and** with a DOT date of week 35 year 1997, coded as 357, or later (see below).
- Note: a) The new U.K. built tyre was introduced on production at VIN: V 1700 (approx).
- b) Italian and U.K. variations of rear tyre should not be mixed on the same axle.
- c) Italian built rear tyres are available under part number A111G6007H, but will be superceded by the new U.K. built version.
- d) U.K. built Lotus approved rear tyres are available under part number A111G6022H.
- e) The DOT code is moulded on the outside wall, with only the last number group relevant to this issue. Note that the three digits represent a date code as explained above, and not an ordinary sequential number.

Pirelli Zero 225/45 rear tyres: There are variations in the specification of this Pirelli tyre dependent on when it was manufactured. For the Elise, use only tyres with a DOT date code of week 35 of year 98, coded as '358' or later.

Alternative Service Fitment

As an alternative to Pirelli tyres, a complete vehicle set of Michelin Pilot SX-GT tyres may be fitted in service using the wider rear tyre specification.

Type		Michelin Pilot SX-GT
Size - front		185/55 R15 81V (Lotus part no. A111G6020H)
- rear		225/45 ZR16 89V (Lotus part no. A111G6021H)
Pressure (cold) - front		1.6 bar (23 lb/in ²)
- rear		1.7 bar (24.5 lb/in ²)

It is not recommended to mix Pirelli and Michelin tyres on the same vehicle.



GF.2 - WINTER TYRES & SNOW CHAINS

If the car is to be used in very cold territories, or driven on snow covered roads, it is recommended to fit winter tyres developed specifically for such conditions. Lotus approves the fitment of Michelin X M+S 130 winter tyres in the following sizes:

Type	Michelin X M+S 130
Size - front	185/55 R15 81T mounted on standard 15 inch front wheels.
- rear	195/60 R15 88T mounted on standard 15 inch front wheels.
Pressure (cold) - front	1.6 bar (23 lb/in ²)
- rear	1.7 bar (24.5 lb/in ²)

Note that the rear winter tyres are to be mounted on standard 15 inch front wheels rather than the standard 16 inch rear wheels.

WARNING:

- **When winter tyres are fitted, a maximum speed of 118 mph (190 km/h) must be observed.**
- **The tyres are NOT suitable for studding.**

Tyre Chains

Snow chains may be used in extreme conditions only in conjunction with winter tyres (see above) and fitted only on the rear wheels. Lotus approves the fitment of Pewag FX 67 S Ring-Super-X snow chains, available under Lotus part number A100G6011F. Close attention should be paid to the fitting and tensioning instructions supplied with the chains, and an appropriate driving style adopted. The chains should be removed as soon as road conditions allow.

GF.3 - EMERGENCY PUNCTURED TYRE INFLATOR

In order to fully exploit the benefits of light weight, and to maximise stowage space and convenience, a 'keep you mobile' punctured tyre inflator aerosol is stowed in the front services compartment. When the aerosol is connected to the tyre valve, and the button pressed, a mixture of liquid latex and propellant is injected into the tyre, such that the solidifying latex is forced into the puncture site at the same time as the tyre is inflated, effecting a temporary repair and enabling the car to be driven at moderate speed to the nearest tyre depot.

WARNING:

- **Use of the aerosol does not constitute a permanent repair, but is designed to allow the car to be driven to the nearest tyre depot. At the earliest opportunity, the tyre should be professionally repaired or replaced dependent on the severity of the damage.**
- **Until the tyre is repaired or replaced, the car should be driven in a moderate manner, not exceeding 30 mph (45 km/h).**
- **The aerosol should not be used for large holes or repairs, or when the tyre sidewall has been damaged, or if the tyre has been displaced from the rim.**
- **The aerosol should be carried at all times in the stowage bracket provided in the front services compartment; never in the passenger compartment.**

Directions for use of the aerosol: As soon as a puncture is suspected, pull off the road at the first safe opportunity. If possible avoid driving on a deflated tyre, or irreparable damage to the tyre may be caused.

Before using the aerosol, carefully read all the instructions on the canister, or on any literature accompanying the product. The following instructions apply to the use of Holts Tyreweld:

1. Remove the object causing the puncture, and position the wheel with the puncture site lowermost. Deflate the tyre fully.
2. Shake the can vigorously. In cold conditions, warm the can using the car's heater outlets, or by body warmth.
3. Screw the aerosol tube onto the tyre valve, remove the cap, hold the can upright and press the button until the tyre is firmly inflated.



4. Immediately drive for 6 - 12 miles (10 - 20 km) (or to the tyre depot if nearer) in a moderate manner and not exceeding 30 mph (45 km/h), to allow the sealant to spread. Then check and adjust the tyre pressure as necessary.
5. Have the tyre professionally repaired or replaced at the earliest opportunity, and until such time, limit speed to 30 mph (45 km/h) with a moderate driving manner. Note that some tyre repairers may make an additional charge for cleaning the sealant off the tyre before repair, and that any subsequent repairs may not be guaranteed.
6. Replace the inflator canister.

GF.4 - SECURITY WHEELNUTS

On cars so equipped, each of the four road wheels is fitted with one security keyed wheel nut in order to deter theft and vandalism. The special splined security nut requires a matching key coded socket before it may be removed using a standard 19mm wheelbrace. For aesthetic purposes, the coded nut is capped by a metal cover, which may be removed using an extractor tool stowed, together with the key coded socket, in a grommet in the windscreen buttress, at the right hand rear corner of the front services compartment.

Push the extractor over the cover until it clips onto the rim, and withdraw the cover. Mate the key coded socket with the nut, and undo using a standard 19mm wheelbrace.

