

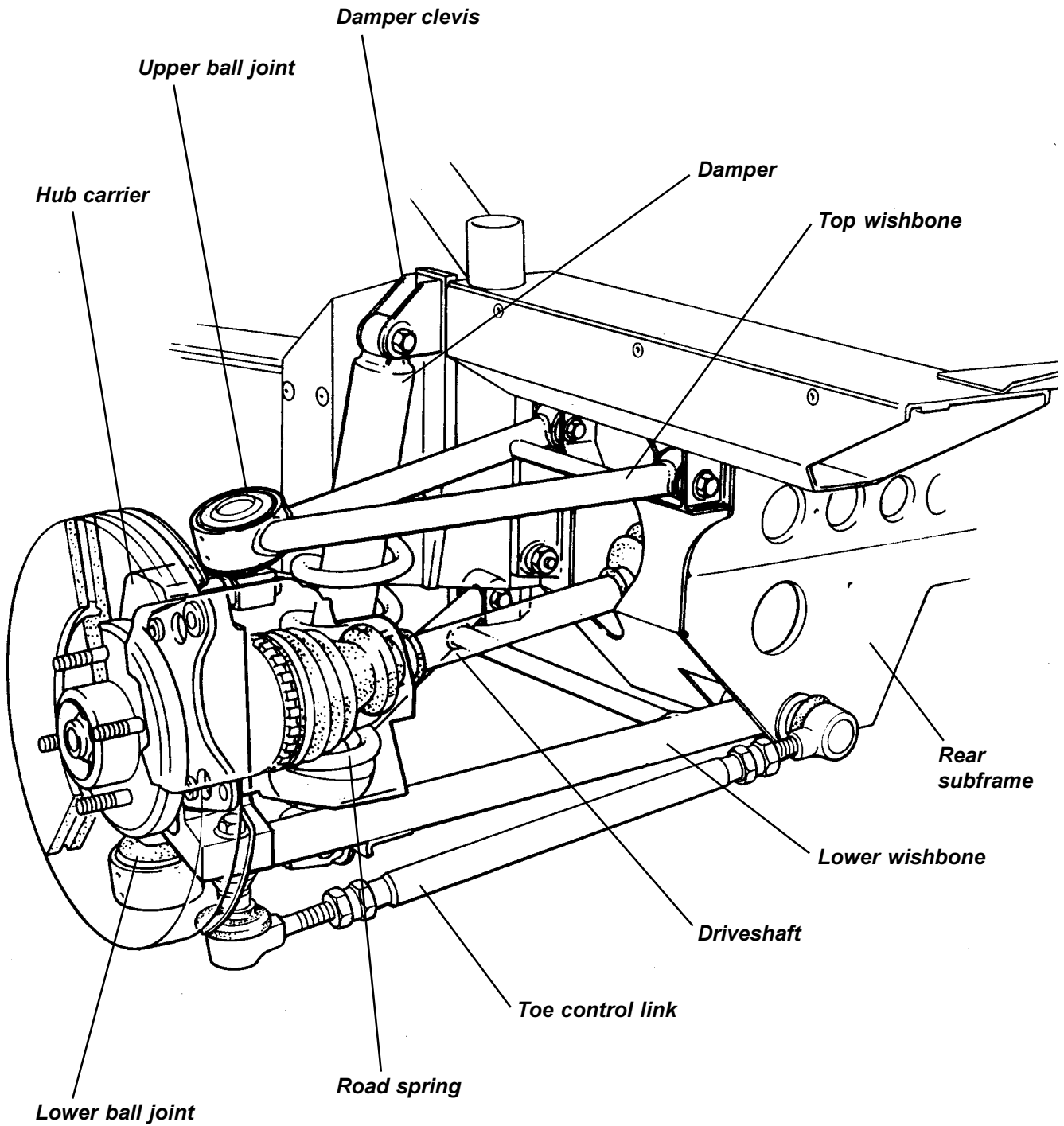

REAR SUSPENSION

SECTION DE - M111 ELISE

	<u>Sub-Section</u>	<u>Page</u>
General Description	DE.1	3
Geometry & Adjustments	DE.2	3
Suspension Disassembly/Assembly	DE.3	5
Rear Toe-Link Fixings	DE.4	8
Rear Wheel Bearings	DE.5	10
Wheel Speed Sensor	DE.6	12
Barrel Shaped Road Springs	DE.7	12





Lower wishbone rear pivot - insert a single 30mm long bush from the front end of the eye.
Lower wishbone front pivot - insert a 16mm long bush into each end of the front eye.

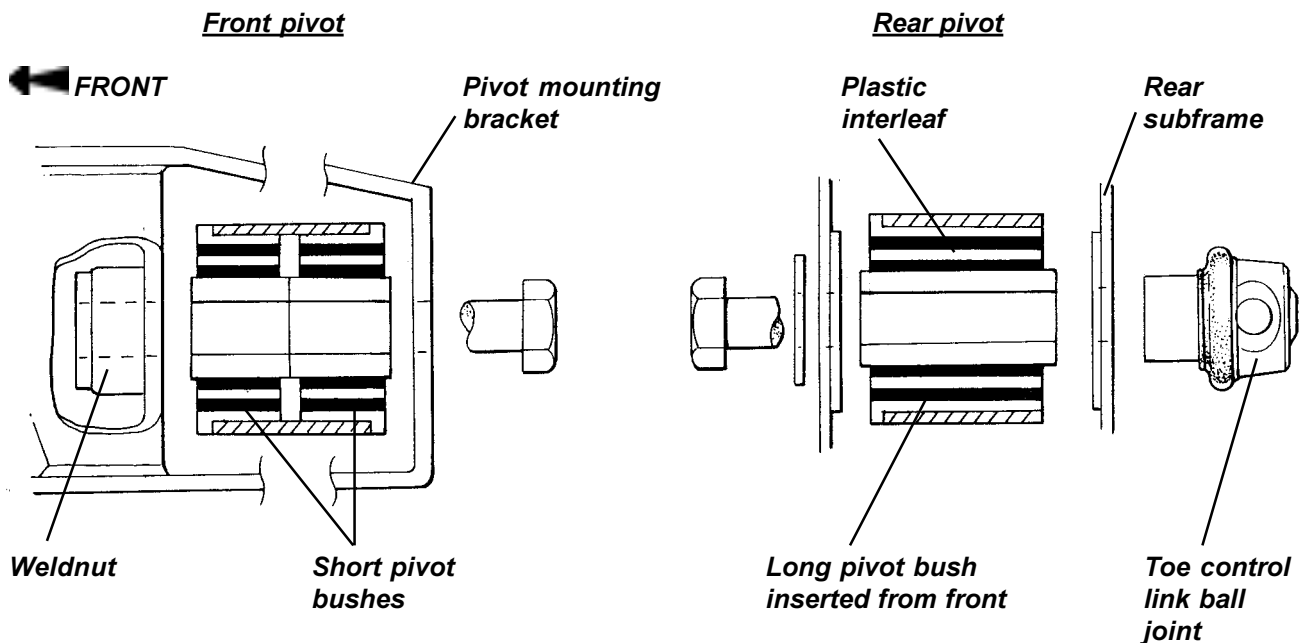

12. The road spring may be removed from the damper using a suitable spring compressor to allow the spring collar retaining circlip to be released from its damper body groove. Note that the springs were changed in June '98 from parallel (black) to barrel shaped (graphite) for improved spring stability. For parallel springs, the middle spring abutment circlip groove is used, whereas the barrel shaped springs use the top groove (lowest ride height).
13. Re-assemble the suspension in reverse order to disassembly with the following notes:
 - **For assembly of the rear toe-link, refer to sub-section DE.4.**
 - Smear the shank of each pivot bolt with PBC grease.
 - Apply Permabond A131 (A912E7034) to the threads of any bolts tapping directly into the alloy hub carrier (except early type hub carriers with tapped holes for the brake caliper mounting plate fixings - see sub-section DE.5).
 - Apply Permabond A130 (A912E7033) to the threads of the lower wishbone front pivot bolts (weldnuts).
 - Coat the joint faces of the hub carrier with any steel component (e.g. swivel joint plinth, camber shim plates etc.) with Duralac MSDS anti-corrosive jointing compound (A111C6017), and assemble whilst the compound is still tacky.
 - The lower ball joint pin must be tightened into the plinth before fitting the plinth to the hub carrier.
 - Take care to refit the original camber adjustment shimpack.
 - Lubricate the ends of the damper eye bushes with rubber grease.
 - Before re-fitting the driveshaft, first renew the round section circlip (A100R6001F) on the end of the inboard joint spigot shaft. Also, check the condition of the transmission output seal, and renew if necessary. Lubricate the lip of the seal with transmission oil, and grease the corresponding shoulder on the driveshaft (C.V. joint) spigot, to reduce the danger of damaging the seal on assembly. Carefully insert the shaft assembly into the transmission with the (lubricated) circlip fitted on the end of the spigot shaft. Press the C.V. joint into the differential gear splines until a 'click' indicates that the circlip has engaged in its location. Pull on the body of the joint to check security.
 - After refitting the brake caliper, press the brake pedal to reposition the pads before driving the car.
14. The Service Schedule specifies that the security of the front and rear suspension is checked at each service. This operation requires that all the principal suspension pivot bolts are torque checked, noting the following points:

Where a bolt is tapped into a housing or weldnut, and relies on a thread locking compound for security, it



is important to appreciate that if the bolt is disturbed, the locking compound must be re-applied. The following procedure should be adopted for all such fixings:

- Check the torque of the fixing.
- If the specified torque is attained without the fixing being disturbed (moving), take no further action.
- If the bolt moves, the locking action of the thread adhesive will have been lost. Remove the bolt completely, clean off all old adhesive with wire brush and acetone, and apply new adhesive as specified.
- Refit the bolt and tighten to the specified torque.
- If for any reason a bolt is found to have become loose, and the car has been operated for any period in this condition, the bolt should be renewed as a standard precaution.

Torque Settings:	Nm
- Upper and lower wishbone pivot bolts	45
- Upper and lower swivel joints to plinth	55
- Upper swivel joint plinth to hub carrier	45
- Lower swivel joint plinth to hub carrier	45
- Toe link outer ball joint to hub carrier	45
- Toe link ball joint lock nuts	78
- Damper to lower wishbone	45
- Damper to chassis	45
- Caliper mounting bracket to hub carrier (early - tapped into carrier)	45
- Caliper mounting bracket to hub carrier (later - through bolted)	62
- Brake caliper to mounting bracket - upper M10	45 - 50
- Brake caliper to mounting bracket - lower M8	26 - 30
- Rear hub nut	220

DE.4 - REAR TOE-LINK FIXINGS

The inboard end of the rear toe-link shares its fixing to the chassis with the lower wishbone rear pivot bush. The outboard end of the link is fixed to a rearward extension of the hub carrier, with a conical spacer and shim washers providing a means of adjusting the amount of toe-in produced with suspension travel - referred to as the 'bump steer' characteristic.

On cars built prior to December '98, the ball pins of the toe link joints incorporate female M10 threads, into which are fitted M10 bolts, the length of which are critical to ensure adequate thread engagement without danger of 'bottoming out' in the joint, with the length of the outboard bolt dependent on the bump steer shim pack. Cars built from December '98 onwards use toe-link ball joints with integral studs, secured to the chassis and hub carrier with M10 Nyloc nuts. The outboard end conical spacer and bump steer shim washers differ for the 'integral stud' type joints, and should not be mixed with the earlier components. Service replacement ball joints are supplied only as integral stud type, complete with associated spacers and shim washers.

Cars built prior to VIN: W 5479 (December '98)

These cars use female threaded ball joints and Permabond A134 thread locking compound for secondary bolt security. A conical spacer and stack of shim washers is fitted between the outer ball joint and the hub carrier in order to provide for adjustment of the bump steer characteristic, the specification for which is fully described in sub-section XA.8. In order to optimise the thread engagement of the outer fixing bolt into the ball joint, for various shim washer configurations, two variations of bolt length are used, and it is vital to follow the build procedure detailed below to ensure complete integrity of the joint.

If the toe-link is released from the hub carrier, note and retain the shim washer stack and conical spacer fitted between the ball joint and hub carrier, and do not disturb the toe-link length setting to avoid the necessity for a subsequent full geometry check. If, on disassembly, the bolt is found to have been significantly below the assembly torque of 45 Nm, such as to allow potential movement between the ball joint and hub carrier, the bolt should be renewed (see below for correct bolt length) and the hub carrier hole and ball joint carefully inspected for wear or damage. If a ball joint requires replacement, the later type 'integral stud' joint should be fitted, together with the associated spacers and shim washers - see below.



Assembly procedure - toe-link inboard fixing ('integral stud' type joint):

Thoroughly clean the stud before fitting through the chassis subframe and wishbone rear bush. Fit the plain washer and a new Nyloc nut, and torque tighten to 45 Nm **only with the car at ride height.**

DE.5 - REAR HUB BEARINGS

Each rear hub carrier houses a sealed dual taper roller bearing with a split inner race. The hub is pressed into the bearing, and the outboard driveshaft is splined into the hub. A nut on the end of the driveshaft both retains the shaft in the bearing, and applies the necessary preload to the bearing assembly. Check for any discernible free play in the hub bearing and for any signs of lubricant expulsion, indicative of seal failure. If free play is evident, or any roughness or tight spots can be felt, the bearing should be replaced. Note that removal of the rear hub will usually result in separation of the hub bearing inner race, necessitating renewal of the bearing.

To Replace Rear Hub Bearing

Note that removal of a rear hub Replacement of the hub bearing is most easily performed with the hub carrier removed to a bench:

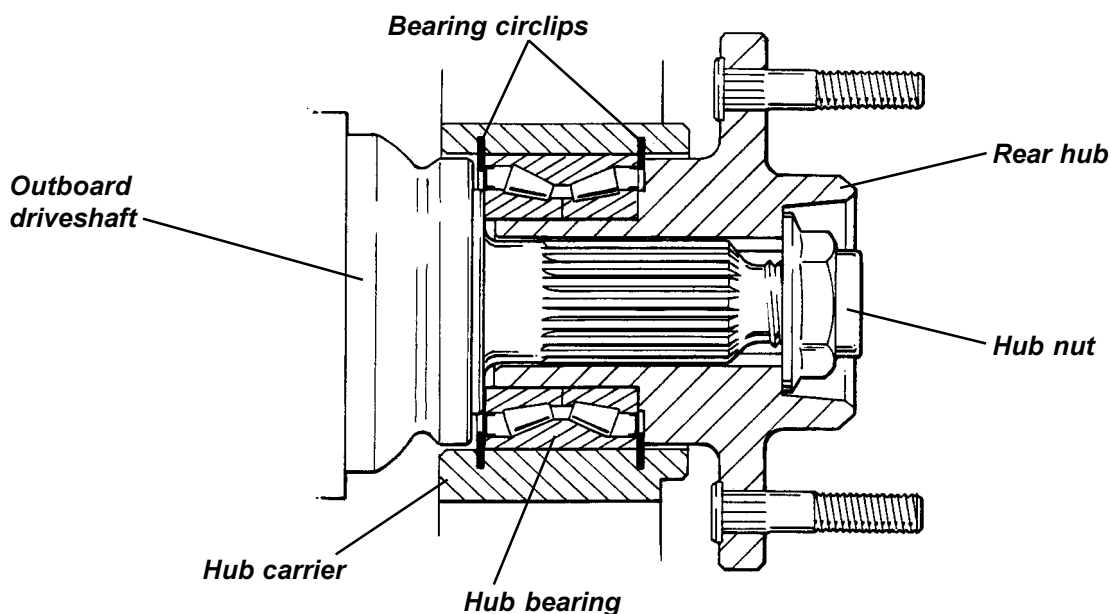

1. With the wheel removed, apply the parking brake and release the driveshaft to rear hub nut. Removal of the nut can be eased by using a punch to knock the distorted end of the nut clear of the driveshaft slot.
2. Remove the two bolts securing the brake caliper to its mounting bracket, and support the caliper clear of the disc without straining the flexible hose or parking brake cable. Withdraw the brake disc from the hub.
3. Remove the wheel speed sensor from the LH hub carrier to prevent damage during driveshaft removal.
4. Remove the two bolts securing the top swivel joint plinth to the hub carrier, noting and retaining the camber adjustment shim pack.
5. Release the bolt securing the outer end of the toe link to the hub carrier, noting the conical spacer.

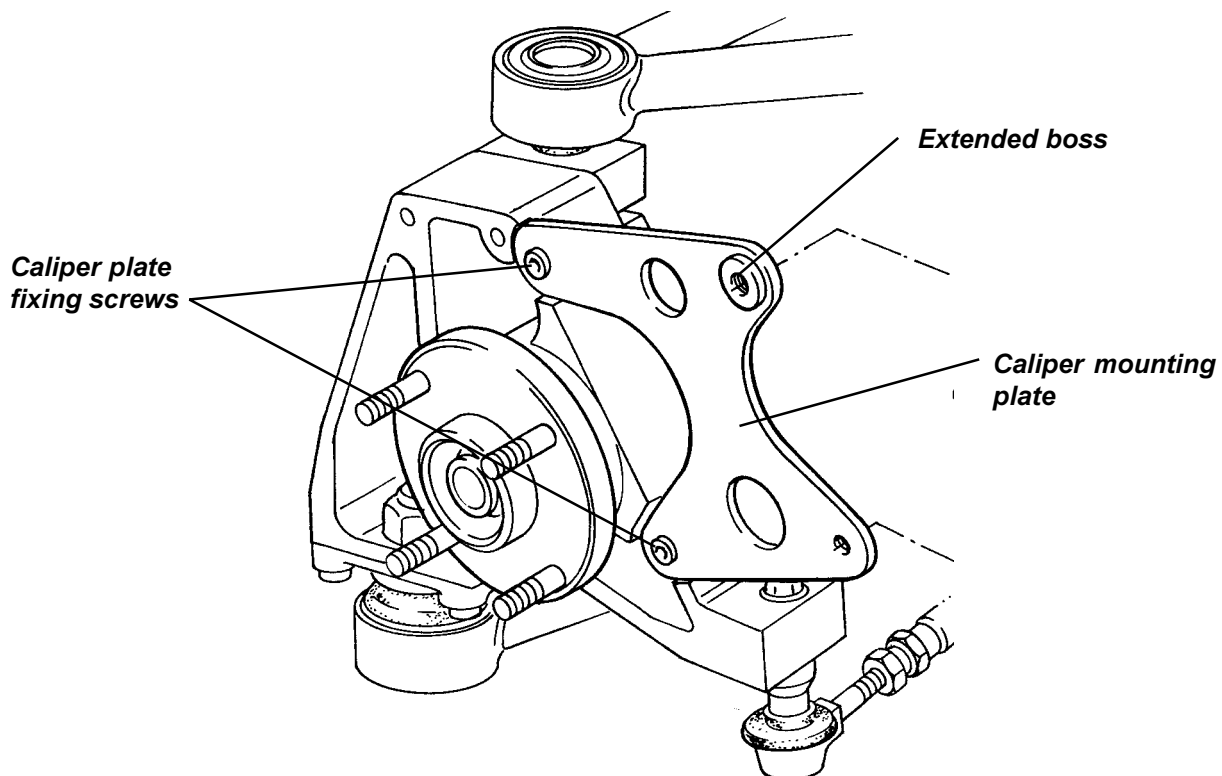

i159

6. Use a puller tool if necessary to extract the outboard driveshaft from the hub.
7. Remove the four screws retaining the lower ball joint plinth to the hub carrier, and withdraw the hub carrier assembly to a bench.
8. Use a hydraulic press to remove the hub from the bearing, and if necessary, use a puller to withdraw the bearing inner race from the hub spigot.
9. Remove both circlips from the hub carrier, and press out the bearing.
10. Before fitting the new bearing, clean any corrosion from the bearing bore outside of the circlip grooves, and fit one circlip into position. Heat the hub carrier in an oven to 90°C for at least 20 minutes before pressing the bearing assembly into the carrier to abut the fitted circlip. Retain by fitting the second circlip.
11. Before fitting the hub, check whether the caliper mounting plate needs to be removed or replaced, as access to the lower fixing is inhibited with the hub in place. When fitting the plate to the hub carrier, ensure that the correct hand of plate is fitted, with the extended boss positioned at the outboard top. The fixing method of the caliper mounting plate to the hub carrier was changed during 1997:
Early type with tapped holes in the hub carrier: Apply Permabond A025 high temperature threadlocking compound (orange) (A912E6800V) to the threads of both shallow caphead M10 setscrews and torque tighten to 44 Nm.
Later type with through bolts and nuts: Torque tighten the bolts and self locking nuts to 62 Nm. Note that if an early car is updated with the later type hub carrier, the top ball joint carrier may have to be relieved to provide clearance for the caliper mounting plate top fixing nut.
12. Supporting the inner race of the hub bearing, press the hub fully into the bearing from the outside.
13. Re-assemble the suspension in reverse order to dis-assembly, referring also to sub-section DE.3. After torque tightening the rear hub nut to 220 Nm, lock the nut to the driveshaft by peening the nut flange into the driveshaft slot.
 Pump the brake pedal to reposition the pads before driving the car.

DE.6 - WHEEL SPEED SENSOR

The wheel speed sensor is used to provide a road speed signal to the speedometer, and is mounted on a bracket fixed to the left hand rear hub carrier. The sensor is easily damaged, and if a driveshaft is to be removed, the sensor should first be withdrawn from its mounting bracket.

The gap between the sensor tip and the pole wheel (toothed ring) pressed onto the driveshaft, is critical and should be checked whenever a driveshaft is re-assembled into a hub carrier, or if a related component is replaced. The specified gap of 0.25 to 1.25 mm may be adjusted if necessary by fitting shim washers between the sensor fixing tab and the mounting bracket. Tighten the sensor fixing screw and bracket fixing screw to 9.3 Nm. Ensure that the toothed ring does not become clogged with mud or accumulated dirt.

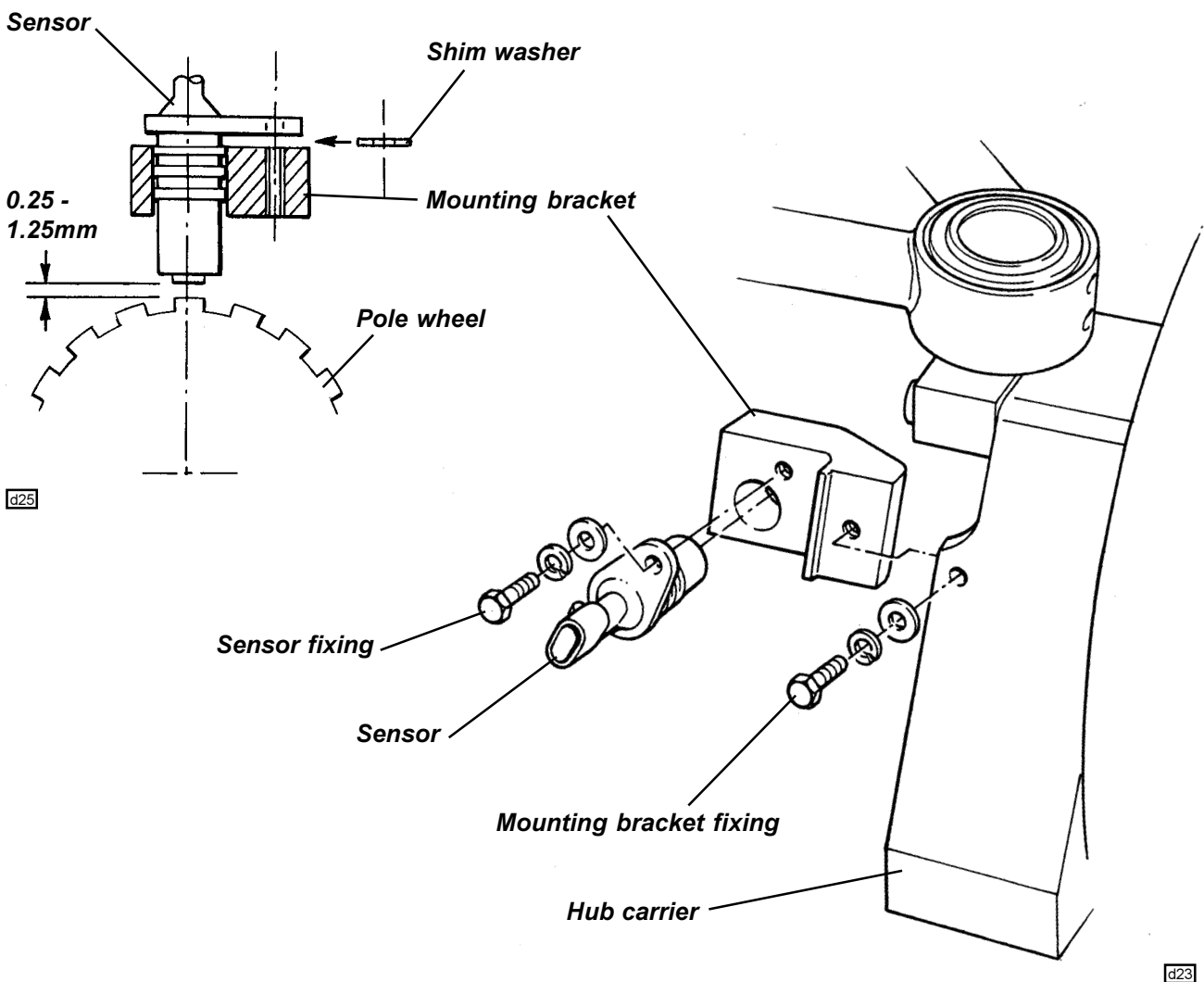
**DE.7 - BARREL SHAPED ROAD SPRINGS**

In June '98 at approx. VIN W 3580, the front and rear road springs were changed from parallel (black painted) to barrel shaped (graphite coloured) in order to provide increased spring stability and reduce the possibility of the spring fouling the damper body. The barrel shaped springs use different abutment grooves in the damper body, and revised rear damper chassis anchor brackets with repositioned (10mm higher) damper pick up holes. If an earlier car is to be updated with the barrel springs, all four springs must be changed, together with the following:



- i) Use the uppermost spring abutment groove on both front and rear damper bodies.
- ii) Replace each rear damper top mounting bracket with new bracket A111D0076F, together with load spreading plate A111D0125F. Discard the plain washers previously used on the fixing bolts.

New type damper top mount

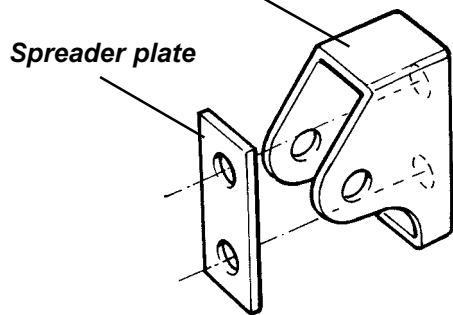

Old type bracket

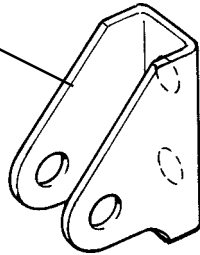

Damper body top groove

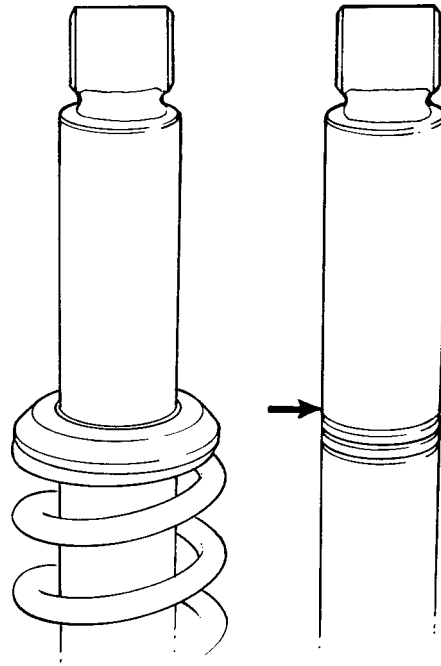

d33

d34